

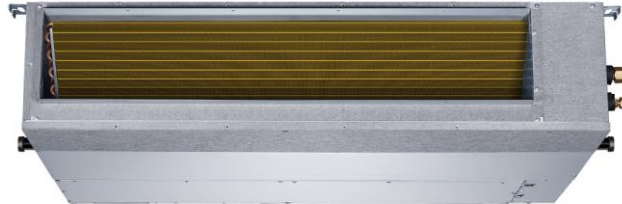

ENGINEER DATABOOK

-T3 R410A Heat Pump-

QSM/QST Series



Manufacturer reserves the right to discontinue, or change at any time, specifications or designs without notice or without occurring obligations.

EDBST0001-Rev-02

1. Specifications 4

- 1. Model Reference
- 2. General Specifications
- 3. Dimensional Drawings
- 4. Electrical Wiring Diagrams
- 5. Refrigerant Cycle Diagrams
- 6. Capacity Tables
- 7. Capacity Correction Factor for Height Difference
- 8. Noise Criterion Curves
- 9. Electrical Characteristics
- 10. Static Pressure

2. Product Features 56

- 1. Operation Modes and Functions
- 2. Remote Controller Functions

3. Static Pressure Design 67

- 1. Introduction
- 2. Charts for Friction Losses in Round Ducts
- 3. Dynamic Losses
- 4. Corresponding Relation Between Rectangular Duct and Round Duct
- 5. Method for Duct Calculation
- 6. Unit Conversion
- 7. Recommended Outlet Velocity for Different Occasions

Chapter 1: Specification

1.	Model Reference.....	5
2.	General Specifications.....	6
3.	Dimensional Drawings.....	11
4.	Electrical Wiring Diagrams.....	14
5.	Refrigerant Cycle Diagrams.....	24
6.	Capacity Tables.....	27
7.	Capacity Correction Factor for Height Difference.....	39
8.	Noise Criterion Curves.....	45
9.	Electrical Characteristics.....	49
10.	Static Pressure.....	50

1. Model Reference

Refer to the following table to determine the specific indoor and outdoor unit model number of your purchased equipment.

Indoor Model	Outdoor Model	Size(Btu/h)	Power Supply
42QSM018VSG	38QST018VS	18K	220-240V~1Ph,50Hz
42QSM024VSP	38QST024VS	24K	
42QSM030VSP	38QST030VS	30K	
42QSM036VSP	38QST036VS	36K	
42QSM048VT	38QST048VT	48K	380-415V 3N~,50Hz
42QSM060VT	38QST060VT	60K	

2. General Specifications

Indoor sale model			42QSM018VSG	42QSM024VSP	42QSM030VSP
Outdoor sale model			38QST018VS	38QST024VS	38QST030VS
Power supply		V,Hz,Ph	220-240V~,1Ph, 50Hz	220-240V~,1Ph, 50Hz	220-240V~,1Ph, 50Hz
Max. input consumption		W	3150	3400	3900
Max. input current		A	14.0	15.0	18.0
Indoor fan motor	Model		ZKFN-160-8-1-2	ZKFN-160-8-1-2	ZKFN-160-8-1-2
	Type		DC	DC	DC
	Qty		1	1	1
	Input	W	176	176	176
	Output	W	160	160	160
	Speed(Hi/Med/Lo)	r/min	1370/1240/1090	940/870/760	1000/920/840
	Insulation class		B	B	B
IP Code			IPX0	IPX0	IPX0
Indoor coil	Number of rows		4.0	3	4
	Tube pitch(a)*row pitch(b)	mm	21x13.37	21x13.37	21x13.37
	Fin spacing	mm	1.4	1.4	1.4
	FPI		18.1	18.1	18.1
	Fin type		Hydrophilic aluminum	Hydrophilic aluminium	Hydrophilic aluminium
	Tube outside dia.and type	mm	Φ7,Inner groove tube	Φ7,innergroove tube	Φ7,innergroove tube
	Coil lengthxheightxwidth	mm	695x252x53.48	915x294x40.11	915x294x53.48
	Number of circuits		6	7	7
Indoor air flow (Hi/Med/Lo) (under rated ESP)		m ³ /h	970/805/630	1365/1100/880	1420/1210/990
ESP	Rated	Pa	25	25	37
	Range	Pa	0-100	0-160	0-160
Indoor noise level (Hi/Med/Lo) (under rated ESP)		dB(A)	43/39/34	40/38/36	43/40.5/38
Indoor unit	Dimension (WxDxH)	mm	880x674x210	1100x774x249	1100x774x249
	Packing(WxDxH)	mm	1070x725x280	1305x805x305	1305x805x305
	Net/Gross weight	kg	25.8/31	32.6/39.9	33.1/40.4
Drainage water pipe diameter		mm	ODΦ25mm	ODΦ25	ODΦ25
Controller			Wired control	Wired control	Wired control
Operation temperature		℃	20~28	20~28	20~28
Room temperature	Cooling	℃	17~32	17~32	17~32
	Heating	℃	0~30	0~30	0~30
Qty'per 20' /40' /40'HQ		Indoor	120/264/297	77/161/184	77/161/184
Compressor	Model		ASN140D35TFZ	ATF235D22TMT	ATH307CDRC8DUL
	Type		ROTARY	ROTARY	ROTARY
	Brand		GMCC	GMCC	HIGHLY
	Capacity	Btu/h	14245	24345	29377
	Input	W	1085	1970	2660
	Rated current(RLA)	A	7.6	9.0	9.5
	Thermal protector position		INTERNAL	INTERNAL	INTERNAL
	Refrigerant oil	ml	VG75-440	RB75EA/670	RMM68EA or equivalent /1050
Outdoor fan motor	Model		YKS-230-6-6-2	YKS-230-6-6-2	YKS-230-6-6-2
	Type		AC	AC	AC
	Qty		1	1	1
	Input	W	190	190	190
	Output	W	230	230	230
	Speed	r/min	900	900	900
	Insulation class		B	B	B
	IP Code		IPX4	IPX4	IPX4
Outdoor coil	Number of rows		1	1	2
	Tube pitch(a)* row pitch(b)	mm	21x13.37	21x13.37	21x13.37
	Fin spacing	mm	1.3	1.3	1.3
	FPI		19.5	19.5	19.5
	Fin type		Hydrophilic aluminum	Hydrophilic aluminum	Hydrophilic aluminum
	Tube outside dia.and type	mm	Φ7,Inner groove tube	Φ7,Inner groove tube	Φ7,Inner groove tube
	Coil length * height * width	mm	2030*798*13.37	2030*798*13.37	2030*798*26.74
Number of circuits		5	5	5	
Outdoor noise level (sound pressure)		dB(A)	59.0	61.0	64.0
Throttle type			EXV+Piston	EXV+Piston	EXV+Piston
Outdoor unit	Dimension(WxDxH)	mm	710x710x843	710x710x843	710x710x843
	Packing(WxDxH)	mm	738x738x872	738x738x872	738x738x872
	Net/Gross weight	kg	53/57.5	60/64.5	71.0/75.5
Refrigerant	Type		R410A	R410A	R410A
	Charged volume	kg	1.60	2.60	3.60
Design pressure(Max./Disc./Suc.)		MPa	4.9/4.8/1.5	4.9/4.8/1.5	4.9/4.8/1.5
Refrigerant piping	Liquid side/ Gas side	mm(inch)	6.35mm(1/4in)/12.7mm(1/2in)	9.52mm(3/8in)/15.9mm(5/8in)	9.52mm(3/8in)/19mm(3/4in)
	Max. pipe length	m	25	25	30
	Max. difference in level	m	15	15	20
Ambient temperature	Cooling	℃	0~60	0~60	0~60
	Heating	℃	-15~24	-15~24	-15~24
Qty'per 20' /40' /40'HQ		Outdoor uni	42/96/142	42/96/142	42/96/142

Remarks:1.The above design and specifications are subject to change without prior notice for product improvement.

Notes:

1) Capacities are based on the following conditions:

Cooling(T1): - Indoor Temperature 27°C(80.6°F) DB /19 °C(66.2°F) WB

- Outdoor Temperature 35 °C(95°F) DB /24 °C(75.2°F) WB

- Interconnecting Piping Length 5m

- Level Difference of Zero.

Heating: - Indoor Temperature 20°C(68°F) DB / 15°C(59°F) WB

- Outdoor Temperature 7°C(44.6°F) DB / 6°C(42.8°F) WB

- Interconnecting Piping Length 5 m

- Level Difference of Zero.

Cooling(T3): - Indoor Temperature 29°C(84.2°F) DB /19 °C(66.2°F) WB

- Outdoor Temperature 46 °C(114.8°F) DB /24 °C(75.2°F) WB

- Interconnecting Piping Length 5m

- Level Difference of Zero.

2) Capacities are Net Capacities.

3) Due to our policy of innovation some specifications may be changed without notification.

4) City power supply to outdoor unit, indoor power from outdoor side, not allow for separate power supply.

Indoor sale model			42QSM036VSP	42QSM048VT	42QSM060VT
Outdoor sale model			38QST036VS	38QST048VT	38QST060VT
Power supply		V,Hz,Ph	220-240V~,1Ph, 50Hz	380-415V, 3N~, 50Hz	380-415V, 3N~, 50Hz
Max. input consumption		W	4400	6500	6500
Max. input current		A	20.0	13.0	13.0
Indoor fan motor	Model		ZKFN-300-8-1	ZKFN-560-8-1-1	ZKFN-560-8-1-1
	Type		DC	DC	DC
	Qty		1	1	1
	Input	W	420	560	560
	Output	W	300	560	560
	Speed(Hi/Med/Lo)	r/min	930/840/770	1020/800/600	990/910/840
	Insulation class		B	B	B
IP Code			IPX0	IPX0	IPX0
Indoor coil	Number of rows		4	4	4
	Tube pitch(a)*row pitch(b)	mm	21x13.37	25.4x22	25.4x22
	Fin spacing	mm	1.5	1.5	1.5
	FPI		16.9	16.9	16.9
	Fin type		Hydrophilic aluminium	Hydrophilic aluminium	Hydrophilic aluminium
	Tube outside dia.and type	mm	Φ7,innergroove tube	Φ9.52,Inner groove tube	Φ9.52,Inner groove tube
	Coil lengthxheightxwidth	mm	1030x378x53.48	1055x356x88	1195x457x88
	Number of circuits		8	7	9
Indoor air flow (Hi/Med/Lo) (under rated ESP)		m ³ /h	2250/1880/1360	2850/2430/1980	3370/2950/2470
ESP	Rated	Pa	37	50	50
	Range	Pa	0-160	0-200	0-200
Indoor noise level (Hi/Med/Lo) (under rated)		dB(A)	49/46/43	50/47/44	50/47.5/45
Indoor unit	Dimension (WxDxH)	mm	1200x874x300	1200x625x380	1400x858x440
	Packing(WxDxH)	mm	1405x915x365	1485x675x460	1605x910x515
	Net/Gross weight	kg	44.5/52.7	57/64.7	75.5/86.3
Drainage water pipe diameter		mm	ODΦ25	ODΦ25mm	ODΦ25mm
Controller			Wired control	Wired control	Wired control
Operation temperature		°C	20~28	20~28	20~28
Room temperature	Cooling	°C	17~32	17~32	17~32
	Heating	°C	0~30	0~30	0~30
Qty'per 20' /40' /40'HQ		Indoor	62/130/149	59/124/125	35/72/86
Compressor	Model		ATH307CDRC8DUL	KTQ420D41SN5A1	KTQ420D41SN5A1
	Type		ROTARY	ROTARY	ROTARY
	Brand		HIGHLY	GMCC	GMCC
	Capacity	Btu/h	29377	44356	44356
	Input	W	2660	3430	3430
	Rated current(RLA)	A	9.5	6.8	6.8
	Thermal protector position		INTERNAL	INTERNAL	INTERNAL
	Refrigerant oil	ml	RMM68EA or equivalent /1050	VG75/1400	VG75/1400
Outdoor fan motor	Model		YKS-230-6-6-2	YKS-230-6-6-2	YKS-230-6-6-2
	Type		AC	AC	AC
	Qty		1	1	1
	Input	W	190	190	190
	Output	W	230	230	230
	Speed	r/min	850/525	850/525	850/525
	Insulation class		B	B	B
	IP Code		IPX4	IPX4	IPX4
Outdoor coil	Number of rows		2	2	2
	Tube pitch(a)* row pitch(b)	mm	21x13.37	21x13.37	21x13.37
	Fin spacing	mm	1.3	1.3	1.3
	FPI		19.5	19.5	19.5
	Fin type		Hydrophilic aluminum	Hydrophilic aluminum	Hydrophilic aluminum
	Tube outside dia.and type	mm	Φ7,Inner groove tube	Φ7,Inner groove tube	Φ7,Inner groove tube
	Coil length * height * width	mm	2030*798*26.74	2150*798*40.11	2150*798*40.11
	Number of circuits		5	8	8
Outdoor noise level (sound pressure)		dB(A)	63.0	63.0	64.0
Throttle type			EXV+Piston	EXV+Piston	EXV+Piston
Outdoor unit	Dimension(WxDxH)	mm	710x710x843	740x740x843	740x740x843
	Packing(WxDxH)	mm	738x738x872	768x768x872	768x768x872
	Net/Gross weight	kg	71.2/75.7	99.3/104.4	99.8/104.9
Refrigerant	Type		R410A	R410A	R410A
	Charged volume	kg	3.80	4.80	4.80
Design pressure(Max./Disc./Suc.)		MPa	4.9/4.8/1.5	5.1/4.8/1.5	5.1/4.8/1.5
Refrigerant piping	Liquid side/ Gas side	mm(inch)	9.52mm(3/8in)/19mm(3/4in)	9.52mm(3/8in)/19mm(3/4in)	9.52mm(3/8in)/22mm(7/8in)
	Max. pipe length	m	50	50	50
	Max. difference in level	m	30	30	30
Ambient temperature	Cooling	°C	0~60	0~60	0~60
	Heating	°C	-15~24	-15~24	-15~24
Qty'per 20' /40' /40'HQ		Outdoor uni	42/96/142	42/96/142	42/96/142

Remarks:1.The above design and specifications are subject to change without prior notice for product improvement.

Notes:

1) Capacities are based on the following conditions:

Cooling(T1): - Indoor Temperature 27°C(80.6°F) DB /19 °C(66.2°F) WB
- Outdoor Temperature 35 °C(95°F) DB /24 °C(75.2°F) WB
- Interconnecting Piping Length 5m
- Level Difference of Zero.

Heating: - Indoor Temperature 20°C(68°F) DB / 15°C(59°F) WB
- Outdoor Temperature 7°C(44.6°F) DB / 6°C(42.8°F) WB
- Interconnecting Piping Length 5 m
- Level Difference of Zero.

Cooling(T3): - Indoor Temperature 29°C(84.2°F) DB /19 °C(66.2°F) WB
- Outdoor Temperature 46 °C(114.8°F) DB /24 °C(75.2°F) WB
- Interconnecting Piping Length 5m
- Level Difference of Zero.

2) Capacities are Net Capacities.

3) Due to our policy of innovation some specifications may be changed without notification.

4) City power supply to outdoor unit, indoor power from outdoor side, not allow for separate power supply.

Other products information:

1. Compressor Insulation material: Material: PVC + Non spinning fiber.
2. Casing thickness :
 - indoor 18/24/30/36k is 0.6~0.8mm, 0.6mm for top cover, chassis/left panel/right panel is 0.8mm.
 - indoor 48k is 0.8~1.2mm, 0.8mm for top cover/chassis/left panel/right panel, front panel is 1.2mm.
 - indoor 60k is 0.8~1.5mm, 0.8mm for top cover/chassis/left panel/right panel, front panel is 1.5mm.
 - outdoor 18/24/30/36/48/60k is 0.8~1.2mm, 0.8mm for side panel, top cover and chassis is 1.2mm.
3. Filter details (thickness, type, MERV rating):
 - 18/24/30/36k is 10mm thickness aluminum alloy frames with pp net;
 - 48/60k is 5mm thickness iron wire frame with pp net.
 - PS: 18~48k can customize 10mm thickness aluminium alloy frame+aluminium net.
 - Type: nylon; MERV rating: No test data; Filter function: The main function is to prevent large particles of dust into the unit body, prevent dust impact condenser the heat exchange efficiency, and prevent blocking drainage, can purify air.
4. Is supply fan arrangement draw through or blow through?
 - The blower fan is located in front of the cooling coil for 48K and 60K.
 - The cooling coil is located in front of blower fan for 18K, 24K, 30K and 36K.
5. Please advise indoor unit fan material.
 - Fan impeller material: Plastic (ABS), fan casing material: Plastic (HIPS) for 18K,24K, 30K and 36K;
 - Fan impeller material: Metal, fan casing material: Metal for 48K and 60K
6. Outdoor fan blade material
 - Metal
7. TEAO – fan motor (for indoor and outdoor)
 - Indoor motor: normal radiating heat, Outdoor motor: air-cooled

3. Dimensional Drawings

3.1 Indoor Unit

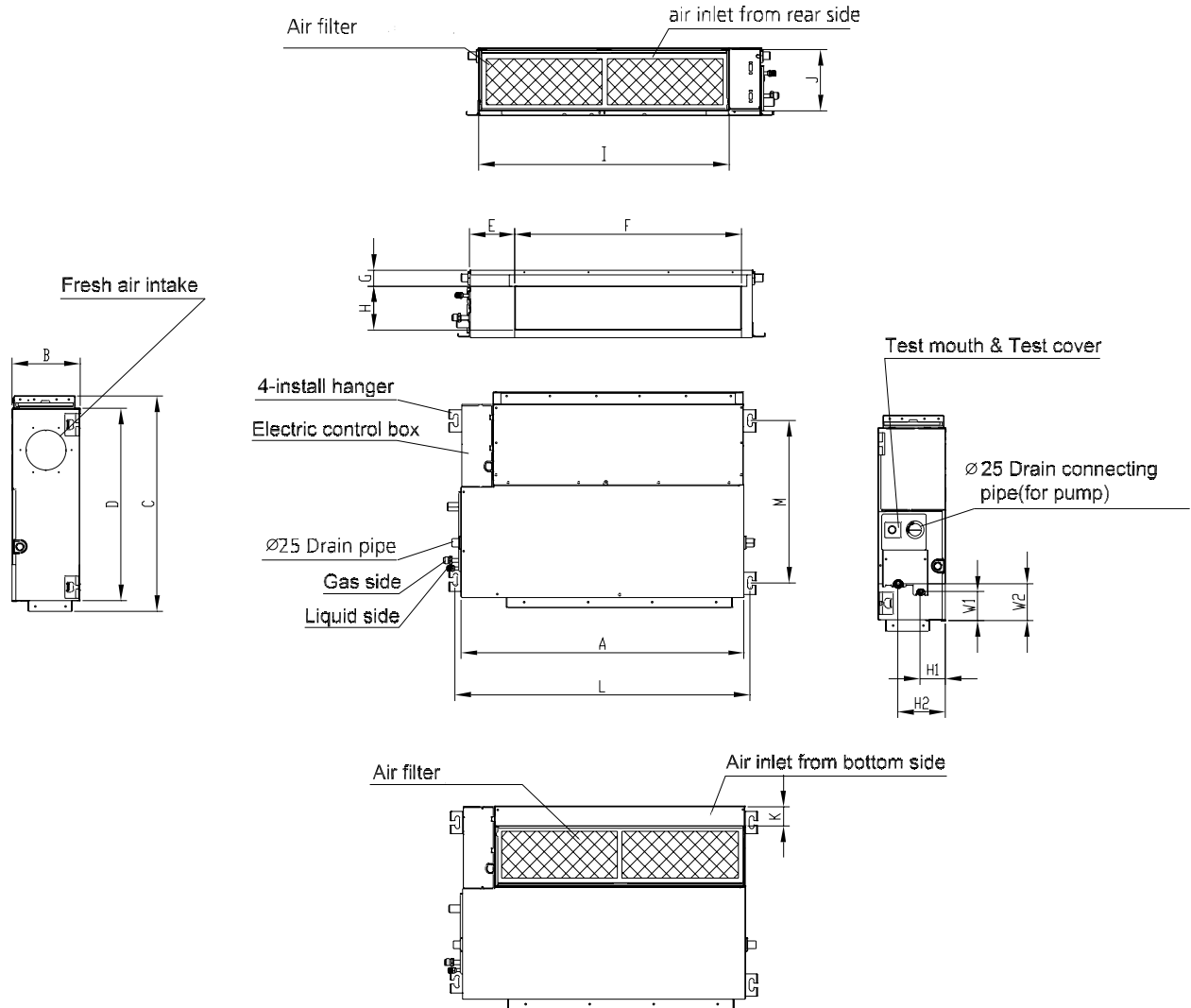

Model	unit	A	B	C	D	E	F	G	H	I	J	K	L	M	H1	H2	W1	W2
18	mm	880	210	674	660	140	706	50	136	782	190	40	920	508	78	148	88	112
	inch	34.65	8.27	26.54	25.98	5.51	27.80	1.97	5.35	30.79	7.48	1.57	36.22	20	3.07	5.83	3.46	4.41
24/30	mm	1100	249	774	700	140	926	50	175	1001	228	5	1140	598	80	150	130	155
	inch	43.31	9.80	30.47	27.56	5.51	36.46	1.97	6.89	39.41	8.98	0.2	44.88	23.54	3.15	5.91	5.12	6.10
36	mm	1200	300	874	800	123	1044	50	227	1101	280	5	1240	697	80	150	185	210
	inch	47.24	11.81	34.41	31.5	4.84	41.1	1.97	8.94	43.35	11.02	0.2	48.82	27.44	3.15	5.91	7.28	8.27

High Static Pressure Duct

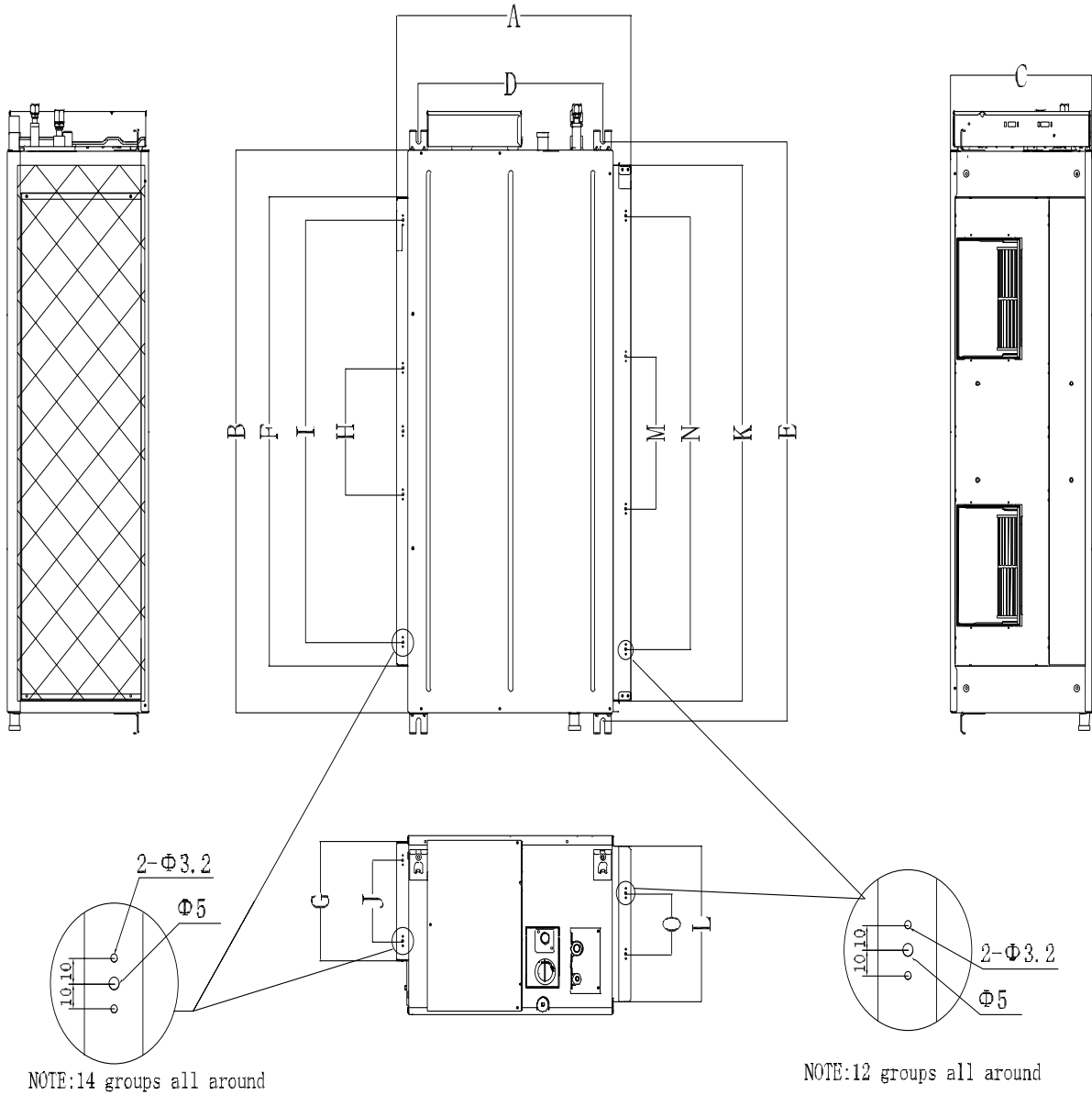

Model (KBtu/h)	unit	Outline dimension			Size of mounted lug		Air outlet opening size(symmetry of air outlet opening)					Air inlet opening size(symmetry of air inlet opening)				
		A	B	C	D	E	F	G	H	I	J	K	L	M	N	O
48	mm	625	1200	380	495	1236	1000	253	270	900	170	1145	334	325	925	130
	inch	24.61	47.24	14.96	19.49	48.66	39.37	9.96	10.63	35.43	6.69	45.08	13.15	12.8	36.42	5.12
60	mm	858	1400	440	700	1436	1188	385	500	1000	280	1188	385	500	1000	280
	inch	33.78	55.12	17.32	27.56	56.54	46.77	15.16	19.69	39.37	11.02	46.77	15.16	19.69	39.37	11.02

3.2 Outdoor Unit

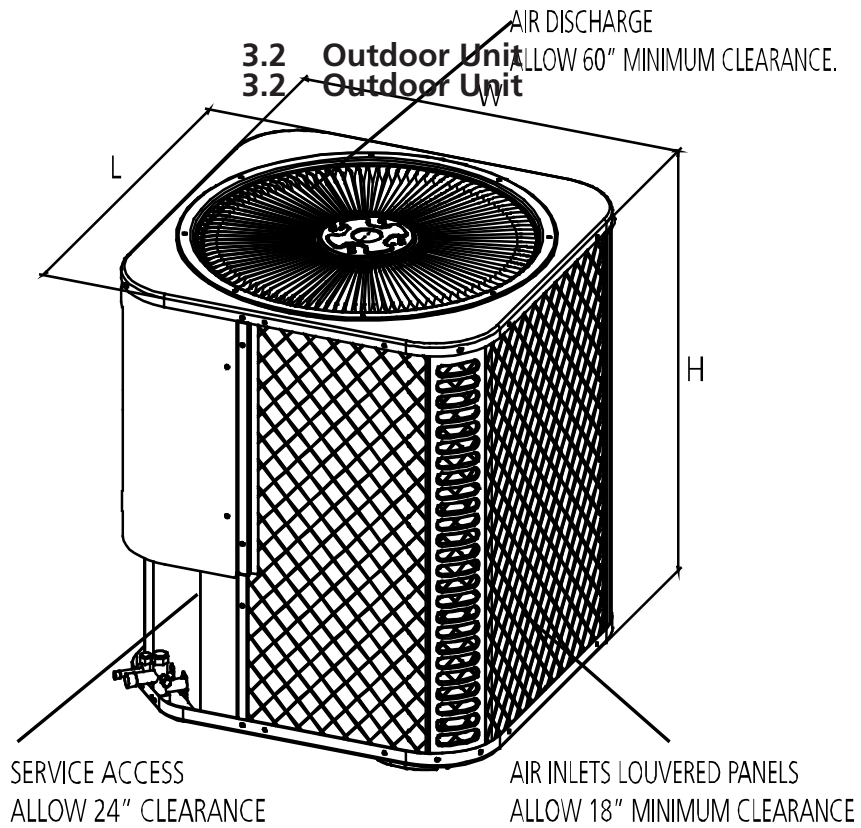

Model (KBtu/h)	unit	Dimensions		
		H	W	L
18/24	mm	843	710	710
	inch	33-3/16	28	28
30/36	mm	843	710	710
	inch	33-3/16	28	28
48/60	mm	843	740	740
	inch	33-3/16	29-1/8	29-1/8

4. Electrical Wiring Diagrams

4.1 Indoor unit

Abbreviation	Paraphrase
Y/G	Yellow-Green Conductor
CAP1	Indoor Fan Capacitor
FAN1	Indoor Fan
AC FAN	Indoor Alternating Current Fan
PUMP	PUMP
L	LIVE
N	NEUTRAL
TO CCM Comm.Bus	Central Controller
T1	Indoor Room Temperature
T2	Coil Temperature of Indoor Heat Exchanger
P1	Super High Speed
P2	High Speed

4.2 Some connectors introduce:

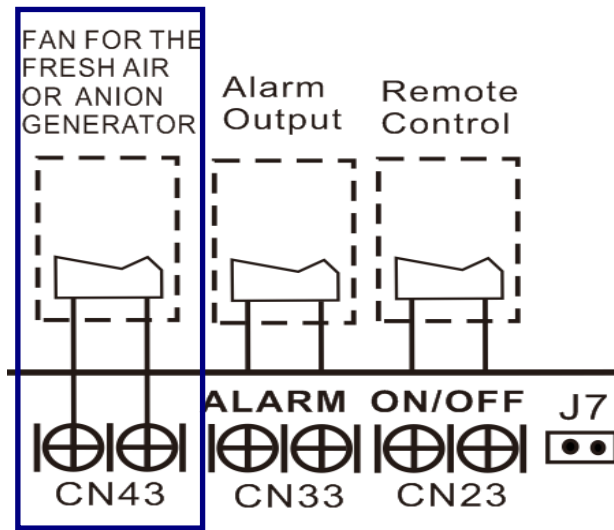

A. For new fresh motor terminal port (also for Anion generator) CN43:

1. Connect the fan motor to the port , no need care L/N of the motor ;
2. The output voltage is the power supply;
3. The fresh motor can not exceed 200W or 1A , follow the smaller one ;
4. The new fresh motor will be worked when the indoor fan motor work ;when the indoor fan motor stops , the new fresh motor would be stopped ;
5. When the unit enter force cooling mode or capacity testing mode , the fresh motor isn't work .

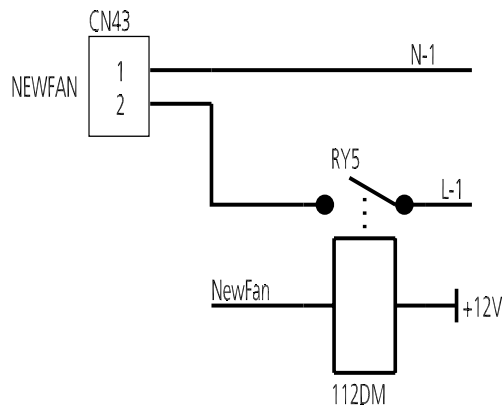

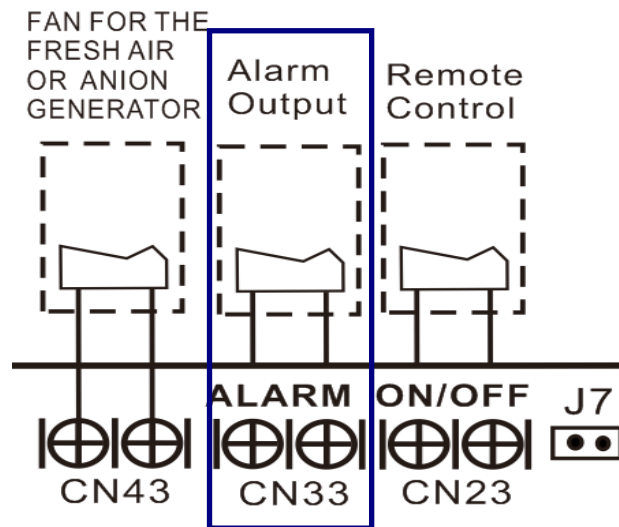

B For ALARM terminal port CN33

1. Provide the terminal port to connect ALARM ,but no voltage of the terminal port , the power from the ALARM system (not from the unit)
2. Although design voltage can support higher voltage ,but we strongly ask you connect the power less than 24V, current less than 0.5A
3. When the unit occurs the problem , the relay would be closed , then ALARM works

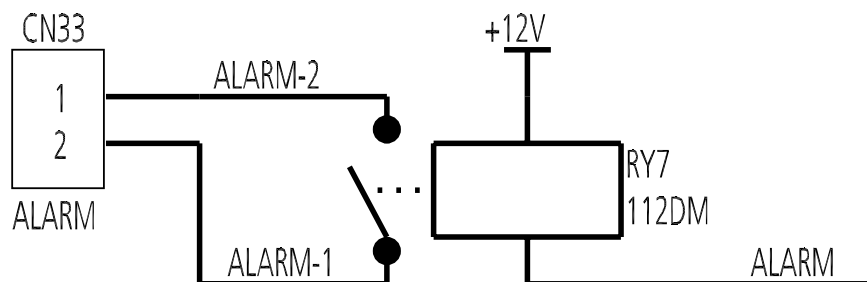

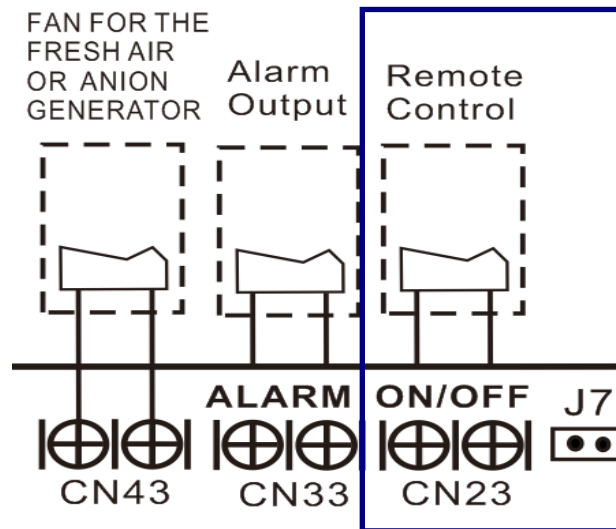

C. For remote control (ON-OFF) terminal port CN23 and short connector of J7

1. Remove the short connector of J7 when you use ON-OFF function;
2. When remote switch off (OPEN) ;the unit would be off;
3. When remote switch on (CLOSE) ;the unit would be on;
4. When close/open the remote switch, the unit would be responded the demand within 2 seconds;
5. When the remote switch on . you can use remote controller/ wire controller to select the mode what you want ;when the remote switch off , the unit would not respond the demand from remote controller/wire controller.

when the remote switch off , but the remote controller / wire controller are on, CP code would be shown on the display board.

6.The voltage of the port is 12V DC, design Max.current is 5mA.

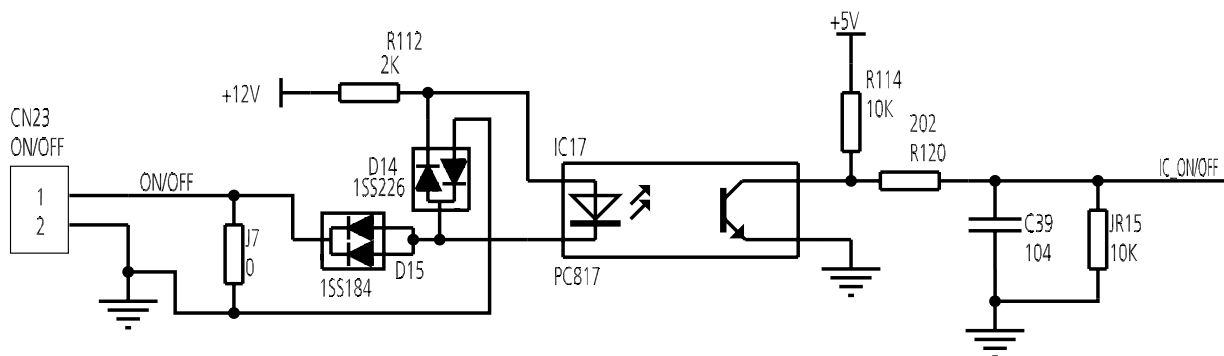



4.3 Micro-Switch introduce:



FOR ANTI-COLD WIND				
SW1				
TELO	24°C	15°C	8°C	EEPROM DEFAULT
FACTORY SETTING	✓			

A. Micro-switch SW1 is for selection of indoor fan stop temperature (TELO) when it is in anti-cold wind action in heating mode.

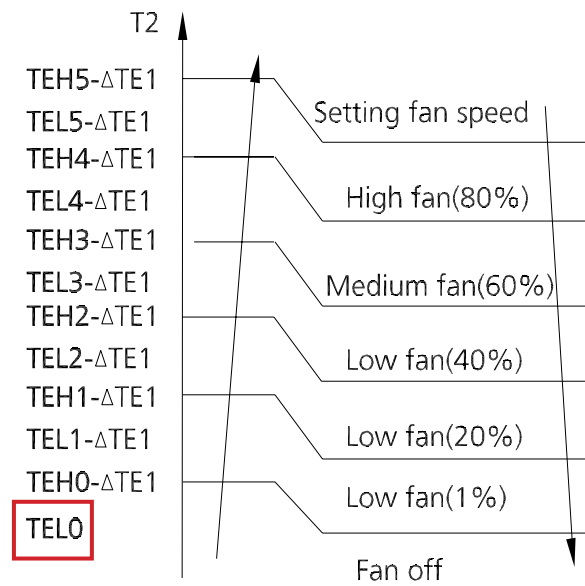
Range: 24°C, 15°C, 8°C, according to EEROM setting (reserved for special customizing).

FOR SETTING FAN MOTOR CONTROL WHEN THERE IS NO DEMAND		
SW2		
MODE	FAN OFF	FAN ON
FACTORY SETTING	✓	

B. Micro-switch SW2 is for selection of indoor FAN ACTION if room temperature reaches the set point and the compressor stops.

Range: OFF (in 127s), Keep running.



FOR SETTING AUTO-RESTART		
SW3		
MODE	AUTO-RESTART	NOT AUTO-RESTART
FACTORY SETTING	✓	

C. Micro-switch SW3 is for selection of auto-restart function.

Range: Active, inactive



FOR TEMP. COMPENSATION(HEATING)				
SW6				
CODE	6°C	2°C	4°C	EEPROM DEFAULT
FACTORY SETTING	✓			

D. Micro-switch SW6 is for selection of temperature compensation in heating mode. This helps to reduce the real temperature difference between ceiling and floor so that the unit could run properly. If the height of installation is lower, smaller value could be chosen.

Range: 6°C, 4°C, 2°C, E function (reserved for special customizing)

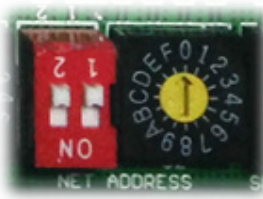

FOR SETTING NETADDRESS				
S1+S2				
CODE	0~F	0~F	0~F	0~F
NETADDRESS	0~15	16~31	32~47	48~63
FACTORY SETTING	✓			

E. Micro-switch S1 and dial-switch S2 are for address setting when you want to control this unit by a central controller.

Range: 00-63



FOR SETTING POWER(DC MOTOR MODEL ONLY)										
ENC1										
CODE	0	1	2	4	5	7	8	9	A	B
POWER	20	26	32-35	36-53	54-71	72-90	91-105	106-140	141-160	161-200
FACTORY SETTING	ACCORDING TO RELATED MODEL.									

F. Dial-switch ENC1: The indoor PCB is universal designed for whole series units from 7K to 68K. This ENC1 setting will tell the main program what size the unit is.

NOTE: Usually there is glue on it because the switch position cannot be changed at random unless you want to use this PCB as a spare part to use in another unit. Then you have to select the right position to match the size of the unit.

“20” means 2kW (7K), “105” means 10.5kW(36K), and so on.



FOR MAIN-SLAVE SETTING				
SW5				
MODE	MAIN NO SLAVE	MAIN	MAIN	SLAVE
FACTORY SETTING	✓			

G. Micro-switch SW5 is for setting the master or slave unit when the unit is in twin connection.

Range: Master no slave (Normal 1 drive 1 connection), Master (2 positions without difference), Slave

4.4 Outdoor Unit

Abbreviation	Paraphrase
CAP1, CAP2	Fan Motor Capacitor
COMP	Compressor
FM1, FM2	Outdoor DC Fan
FAN1, FAN2	Outdoor AC Fan
KM8	Contactator
CT1	AC Current Detector
D	Diode Module
EEV	Electronic Expansion Valve
H-PRO	High Pressure Switch
L-PRO	Low Pressure Switch/Shorting Stub
L	PFC Inductor
SV	4-Way Valve
TP	Exhaust Temperature Sensor
T4	Outdoor Ambient Temperature
T3	Coil Temperature of Condenser
TH	Heatsink Temperature Sensor

18k, 24, 30, 36k

WIRING DIAGRAM (OUTDOOR UNIT)

16022000040510

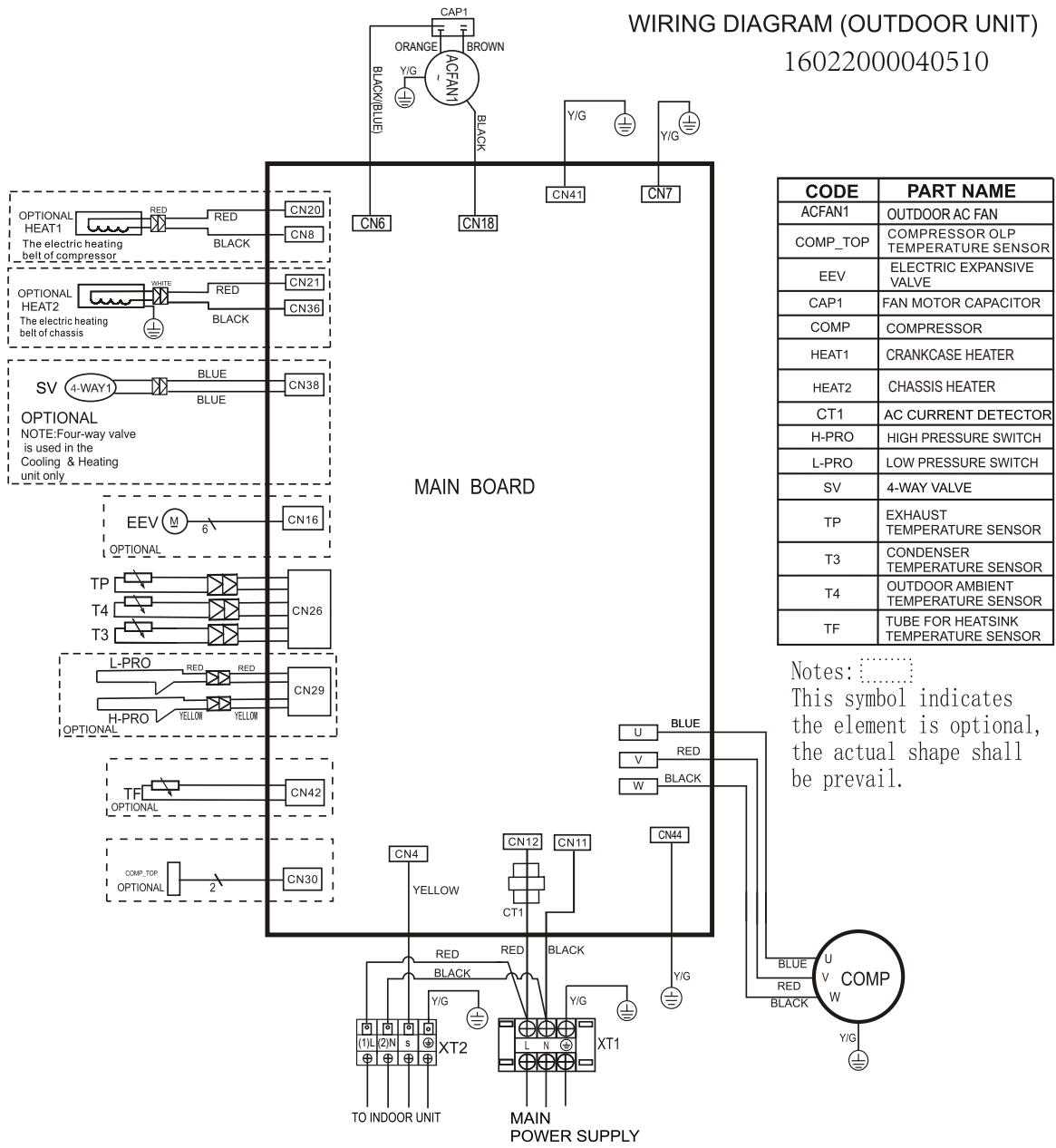

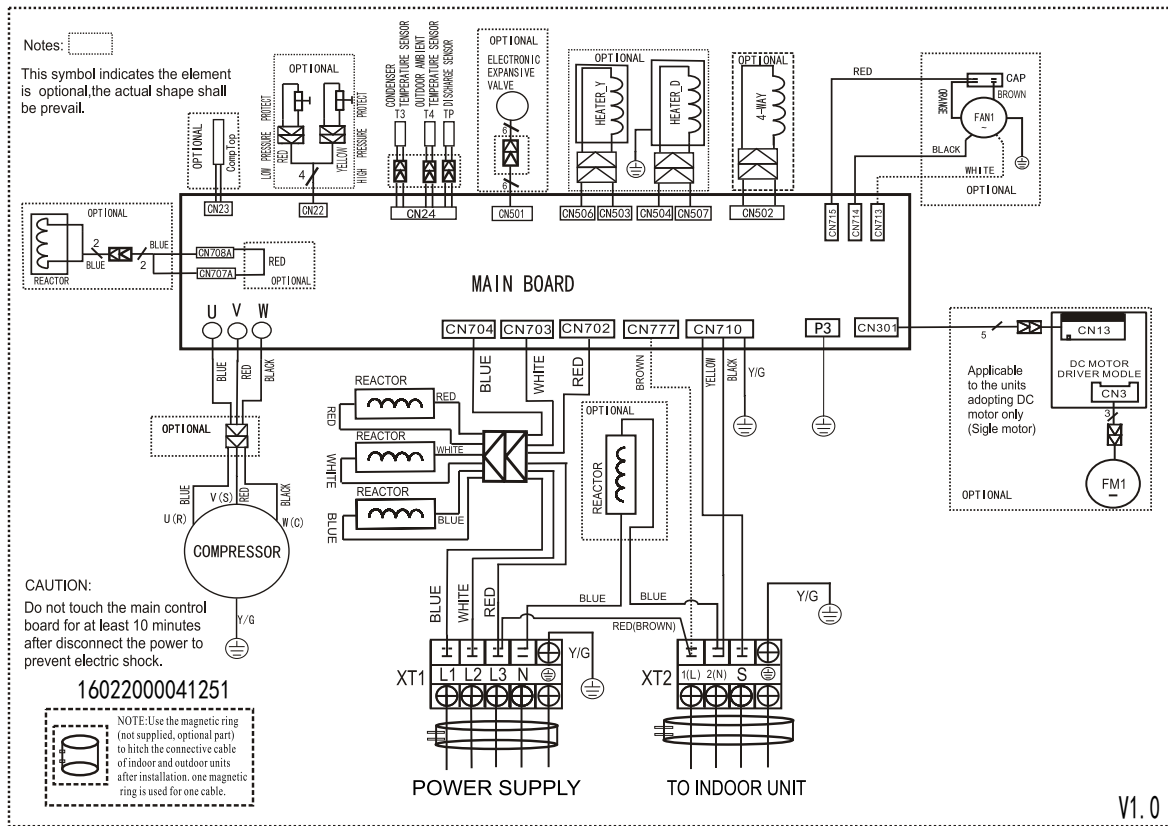

5. Refrigerant Cycle Diagrams

5.1 Heat pump

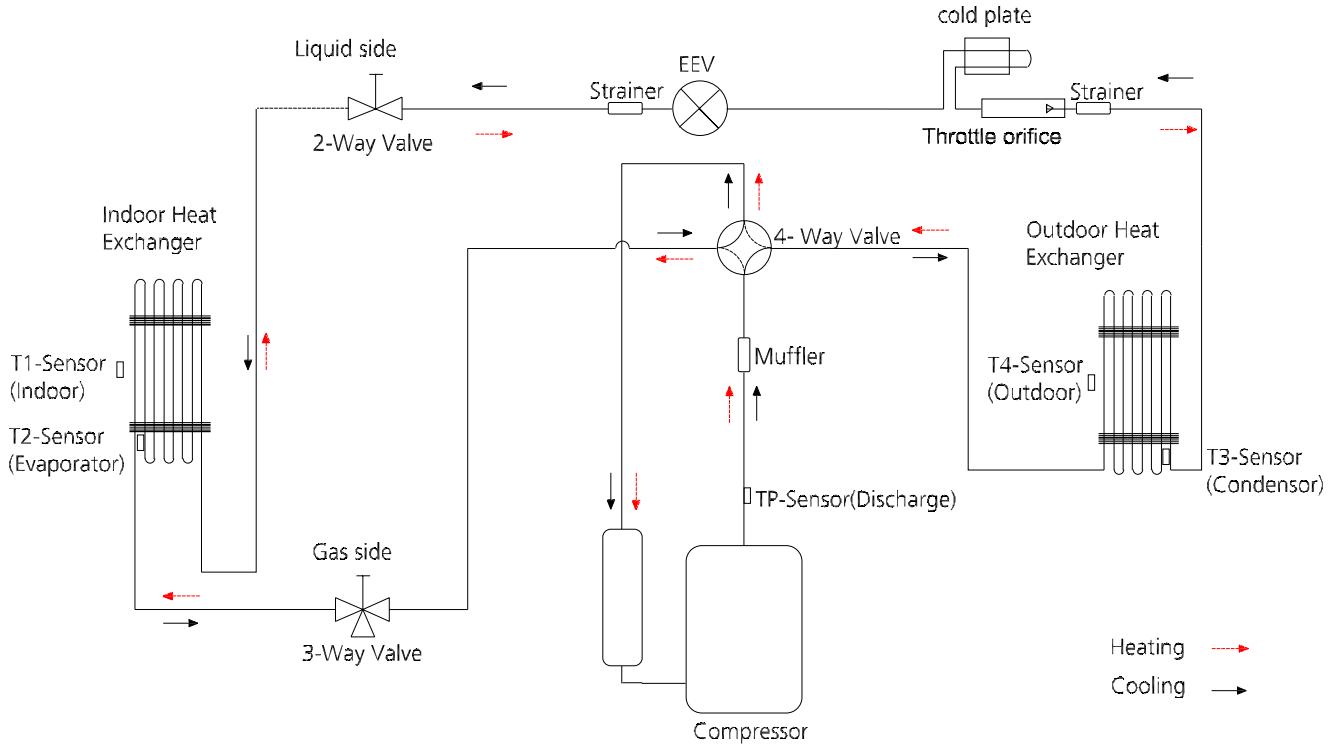

Model(Btu/h)	Pipe Size (Diameter:ø) mm(inch)		Piping length (m/ft)		Elevation (m/ft)		Additional Refrigerant
	Gas	Liquid	Rated	Max.	Rated	Max.	
18k	12.7(1/2)	6.35(1/4)	5/16.4	25/82	0	15/49.2	15g/m (0.16oz/ft)
24k	15.9(5/8)	9.52(3/8)	5/16.4	25/82	0	15/49.2	30g/m (0.32oz/ft)

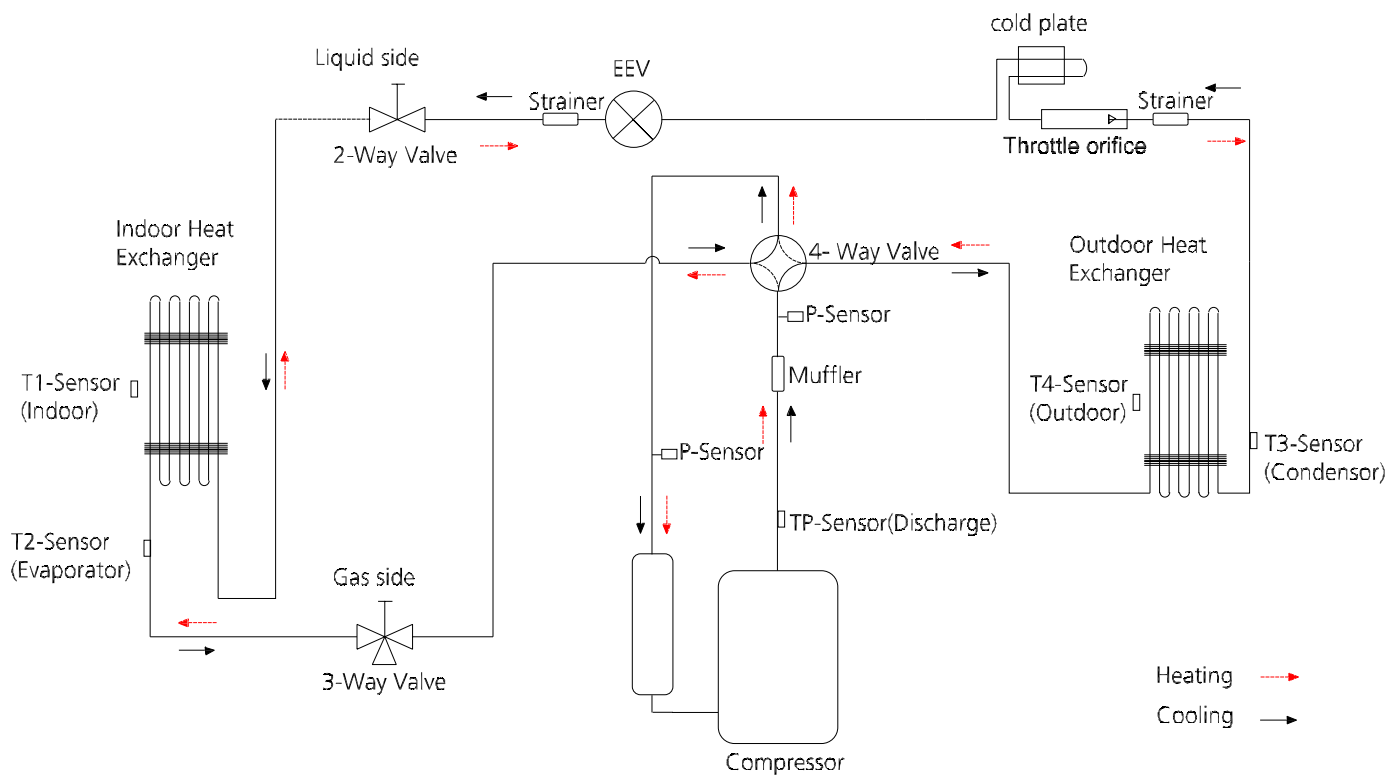

Model No.	Pipe Size (Diameter:ø) mm(inch)		Piping length (m/ft)		Elevation (m/ft)		Additional Refrigerant
	Gas	Liquid	Rated	Max.	Rated	Max.	
30k	19(3/4)	9.52(3/8)	5/16.4	30/98.4	0	20/65.6	30g/m (0.32oz/ft)
36k	19(3/4)	9.52(3/8)	5/16.4	50/164	0	30/98.4	

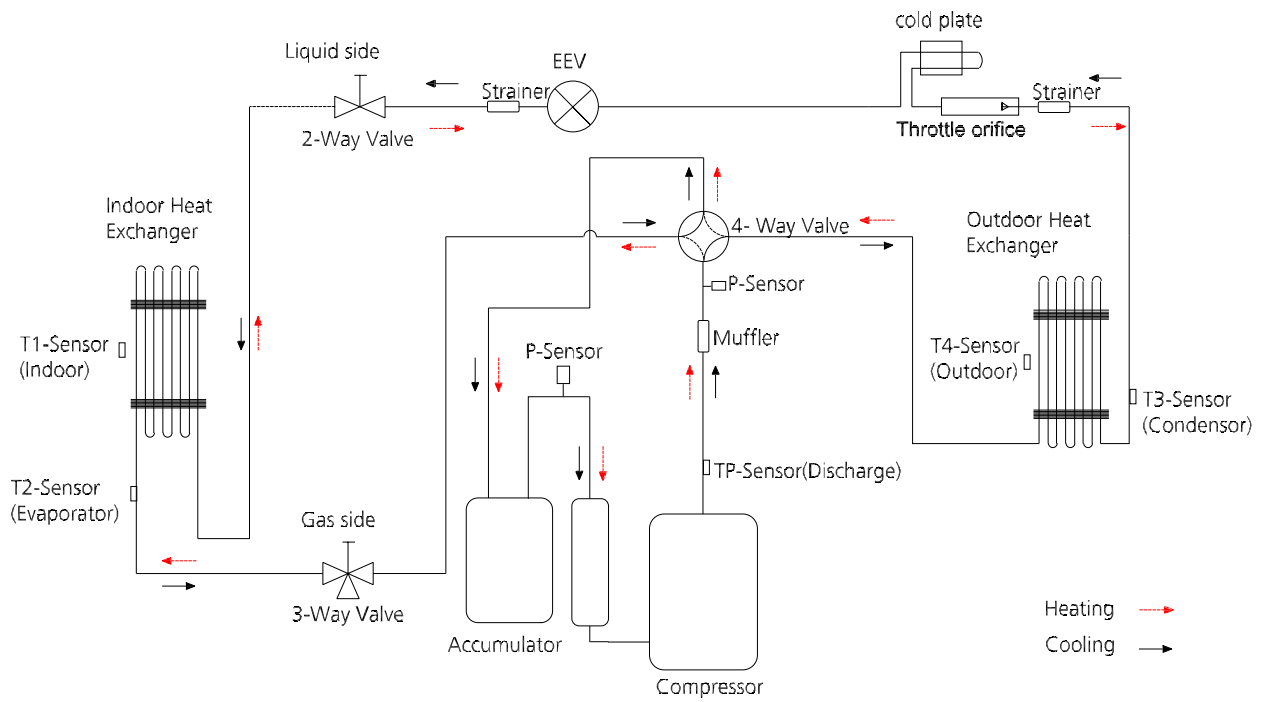

Model No.	Pipe Size (Diameter:ø) mm(inch)		Piping length (m/ft)		Elevation (m/ft)		Additional Refrigerant
	Gas	Liquid	Rated	Max.	Rated	Max.	
48k	19(3/4)	9.52(3/8)	5/16.4	50/164	0	30/98.4	30g/m (0.32oz/ft)
60k	22(7/8)	9.52(3/8)					

6. Capacity Tables

6.1 Cooling

		42QSM018VSG+38QST018VS																	
INDOOR AIRFLOW (L/S)	OUTDOOR DB (°C)	ID WB (°C)	17.2				18.0				19.0				22.0				
			ID DB (°C)	24.4	25.0	27.0	29.0	24.4	25.0	27.0	29.0	24.4	25.0	27.0	29.0	24.4	25.0	27.0	29.0
175	27.0	TC	5.04	5.04	5.04	5.10	5.22	5.22	5.22	5.22	5.36	5.36	5.36	5.36	5.79	5.79	5.79	5.79	
		S/T	0.71	0.73	0.81	0.89	0.64	0.66	0.74	0.82	0.57	0.59	0.67	0.75	0.41	0.44	0.51	0.58	
		PI	1.22	1.22	1.22	1.22	1.22	1.22	1.22	1.22	1.22	1.22	1.22	1.22	1.22	1.22	1.22	1.22	
	30.0	TC	4.90	4.90	4.90	4.96	5.07	5.07	5.07	5.07	5.22	5.22	5.22	5.22	5.62	5.62	5.62	5.62	
		S/T	0.71	0.74	0.82	0.91	0.64	0.66	0.75	0.83	0.57	0.60	0.68	0.76	0.41	0.44	0.51	0.59	
		PI	1.29	1.29	1.29	1.29	1.29	1.29	1.29	1.29	1.29	1.29	1.29	1.29	1.30	1.30	1.30	1.30	
	32.0	TC	4.81	4.81	4.81	4.87	4.96	4.96	4.96	4.96	5.13	5.13	5.13	5.13	5.53	5.53	5.53	5.53	
		S/T	0.72	0.74	0.83	0.91	0.64	0.67	0.75	0.84	0.57	0.60	0.68	0.76	0.41	0.44	0.51	0.59	
		PI	1.34	1.34	1.34	1.34	1.34	1.34	1.34	1.34	1.34	1.34	1.34	1.34	1.35	1.35	1.35	1.35	
	35.0	TC	4.67	4.67	4.67	4.73	4.81	4.81	4.81	4.81	4.96	4.96	5.04	4.96	5.36	5.36	5.36	5.36	
		S/T	0.72	0.75	0.84	0.92	0.65	0.67	0.76	0.85	0.58	0.60	0.68	0.77	0.41	0.44	0.51	0.59	
		PI	1.41	1.41	1.41	1.41	1.41	1.41	1.41	1.41	1.42	1.42	1.42	1.42	1.43	1.43	1.43	1.43	
	43.0	TC	4.10	4.10	4.12	4.15	4.24	4.24	4.24	4.26	4.38	4.38	4.40	4.38	4.72	4.72	4.72	4.72	
		S/T	0.74	0.77	0.87	0.97	0.66	0.69	0.79	0.88	0.59	0.61	0.71	0.80	0.41	0.44	0.52	0.61	
		PI	1.57	1.57	1.57	1.57	1.58	1.58	1.58	1.58	1.58	1.58	1.58	1.58	1.59	1.59	1.59	1.59	
	46.0	TC	3.90	3.90	3.93	3.96	4.04	4.04	4.04	4.07	4.18	4.18	4.18	4.18	4.51	4.51	4.51	4.51	
		S/T	0.75	0.79	0.89	0.99	0.67	0.70	0.80	0.90	0.59	0.62	0.72	0.81	0.41	0.44	0.53	0.62	
		PI	1.64	1.64	1.64	1.64	1.65	1.65	1.65	1.65	1.65	1.65	1.65	1.65	1.65	1.65	1.65	1.65	
	52.0	TC	3.66	3.66	3.69	3.72	3.77	3.77	3.77	3.80	3.92	3.92	3.92	3.92	4.26	4.26	4.26	4.26	
		S/T	0.78	0.82	0.93	1.00	0.69	0.73	0.84	0.94	0.61	0.64	0.74	0.85	0.41	0.44	0.54	0.64	
		PI	1.96	1.96	1.96	1.96	1.96	1.96	1.96	1.96	1.97	1.97	1.97	1.97	1.98	1.98	1.98	1.98	
	224	27.0	TC	5.16	5.16	5.22	5.28	5.33	5.33	5.33	5.39	5.50	5.50	5.50	5.50	5.91	5.91	5.91	5.91
			S/T	0.76	0.79	0.89	0.99	0.67	0.70	0.80	0.90	0.59	0.62	0.72	0.82	0.41	0.44	0.53	0.62
			PI	1.24	1.24	1.24	1.24	1.24	1.24	1.24	1.24	1.24	1.24	1.24	1.24	1.25	1.25	1.25	1.25
30.0		TC	5.02	5.02	5.07	5.13	5.19	5.19	5.19	5.25	5.33	5.33	5.33	5.33	5.76	5.76	5.76	5.76	
		S/T	0.76	0.80	0.90	1.00	0.68	0.71	0.81	0.91	0.60	0.63	0.73	0.83	0.41	0.44	0.53	0.63	
		PI	1.32	1.32	1.32	1.32	1.32	1.32	1.32	1.32	1.32	1.32	1.32	1.32	1.32	1.32	1.32	1.32	
32.0		TC	4.93	4.93	4.99	5.05	5.07	5.07	5.07	5.13	5.25	5.25	5.25	5.25	5.65	5.65	5.65	5.65	
		S/T	0.77	0.80	0.91	1.00	0.68	0.71	0.82	0.92	0.60	0.63	0.73	0.84	0.41	0.44	0.53	0.63	
		PI	1.36	1.36	1.36	1.36	1.37	1.37	1.37	1.37	1.37	1.37	1.37	1.37	1.38	1.38	1.38	1.38	
35.0		TC	4.79	4.79	4.85	4.90	4.93	4.93	4.93	4.99	5.07	5.07	5.16	5.07	5.48	5.48	5.48	5.48	
		S/T	0.78	0.81	0.92	1.00	0.69	0.72	0.83	0.94	0.60	0.64	0.74	0.85	0.41	0.44	0.54	0.64	
		PI	1.44	1.44	1.44	1.44	1.44	1.44	1.44	1.44	1.45	1.45	1.45	1.45	1.45	1.45	1.45	1.45	
43.0		TC	4.24	4.24	4.28	4.31	4.36	4.36	4.40	4.46	4.50	4.50	4.52	4.54	4.87	4.87	4.87	4.87	
		S/T	0.81	0.84	0.96	1.00	0.71	0.75	0.87	0.98	0.62	0.65	0.77	0.88	0.41	0.44	0.55	0.66	
		PI	1.62	1.62	1.62	1.62	1.62	1.62	1.62	1.62	1.63	1.63	1.63	1.63	1.63	1.63	1.63	1.63	
46.0		TC	4.04	4.04	4.07	4.10	4.15	4.15	4.21	4.26	4.29	4.29	4.29	4.34	4.65	4.65	4.65	4.65	
		S/T	0.82	0.86	0.99	1.00	0.72	0.76	0.88	1.00	0.63	0.66	0.79	0.90	0.41	0.45	0.56	0.67	
		PI	1.68	1.68	1.68	1.68	1.68	1.68	1.68	1.68	1.69	1.69	1.69	1.69	1.70	1.70	1.70	1.70	
52.0		TC	3.77	3.80	3.83	3.86	3.89	3.89	3.92	3.94	4.03	4.03	4.03	4.06	4.37	4.37	4.37	4.37	
		S/T	0.86	0.90	1.00	1.00	0.75	0.79	0.93	1.00	0.65	0.69	0.82	0.95	0.41	0.45	0.57	0.91	
		PI	2.01	2.01	2.01	2.01	2.01	2.01	2.01	2.01	2.02	2.02	2.02	2.02	2.03	2.03	2.03	2.03	
269		27.0	TC	5.30	5.30	5.36	5.42	5.45	5.45	5.45	5.50	5.62	5.62	5.62	5.68	6.05	6.05	6.05	6.05
			S/T	0.80	0.84	0.96	1.00	0.71	0.75	0.87	0.98	0.62	0.65	0.77	0.88	0.41	0.44	0.55	0.66
			PI	1.27	1.27	1.27	1.27	1.27	1.27	1.27	1.27	1.27	1.27	1.27	1.27	1.27	1.27	1.27	1.27
	30.0	TC	5.13	5.13	5.19	5.25	5.30	5.30	5.30	5.36	5.45	5.45	5.45	5.50	5.88	5.88	5.88	5.88	
		S/T	0.82	0.85	0.97	1.00	0.72	0.75	0.88	0.99	0.62	0.66	0.78	0.89	0.41	0.45	0.56	0.67	
		PI	1.34	1.34	1.34	1.34	1.34	1.34	1.34	1.34	1.35	1.35	1.35	1.35	1.35	1.35	1.35	1.35	
	32.0	TC	5.05	5.05	5.10	5.16	5.19	5.19	5.25	5.30	5.36	5.36	5.36	5.42	5.76	5.76	5.76	5.76	
		S/T	0.82	0.86	0.98	1.00	0.72	0.76	0.88	1.00	0.63	0.66	0.79	0.90	0.41	0.45	0.56	0.67	
		PI	1.39	1.39	1.39	1.39	1.39	1.39	1.39	1.39	1.40	1.40	1.40	1.40	1.40	1.40	1.40	1.40	
	35.0	TC	4.87	4.87	4.93	4.99	5.05	5.05	5.10	5.16	5.19	5.19	5.28	5.33	5.59	5.59	5.59	5.59	
		S/T	0.83	0.87	1.00	1.00	0.73	0.77	0.89	1.00	0.63	0.67	0.79	0.91	0.41	0.45	0.56	0.68	
		PI	1.47	1.47	1.47	1.47	1.47	1.47	1.47	1.47	1.48	1.48	1.48	1.48	1.49	1.49	1.49	1.49	
	43.0	TC	4.32	4.34	4.40	4.46	4.47	4.47	4.53	4.58	4.61	4.61	4.63	4.69	4.98	4.98	4.98	4.98	
		S/T	0.87	0.91	1.00	1.00	0.76	0.80	0.94	1.00	0.65	0.70	0.83	0.96	0.42	0.45	0.58	0.90	
		PI	1.65	1.65	1.65	1.65	1.65	1.65	1.65	1.65	1.66	1.66	1.66	1.66	1.67	1.67	1.67	1.67	
	46.0	TC	4.12	4.15	4.21	4.26	4.26	4.26	4.32	4.37	4.40	4.40	4.40	4.45	4.76	4.76	4.76	4.76	
		S/T	0.89	0.93	1.00	1.00	0.77	0.82	0.96	1.00	0.66	0.71	0.85	0.98	0.42	0.46	0.59	0.92	
		PI	1.71	1.71	1.71	1.71	1.72	1.72	1.72	1.72	1.72	1.72	1.72	1.72	1.74	1.74	1.74	1.74	
	52.0	TC	3.86	3.89	3.92	3.94	3.97	3.97	4.00	4.03	4.12	4.12	4.14	4.17	4.46	4.46	4.46	4.46	
		S/T	0.93	0.98	1.00	1.00	0.81	0.86	1.00	1.00	0.69	0.74	0.89	1.00	0.42	0.46	0.61	0.97	
		PI	2.05	2.05	2.05	2.05	2.05	2.05	2.05	2.05	2.06	2.06	2.06	2.06	2.08	2.08	2.08	2.08	

TC: Total Capacity(kW)

S/T: Sensible Capacity ratio

PI: Power Input(kW)

Note: Above deration table showing the data was simulated basing on a fixed compressor speed.

42QSM024VSP+38QST024VS																			
INDOOR AIRFLOW (L/S)	OUTDOOR DB (°C)	ID WB (°C)	17.2				18.0				19.0				22.0				
			ID DB (°C)	24.4	25.0	27.0	29.0	24.4	25.0	27.0	29.0	24.4	25.0	27.0	29.0	24.4	25.0	27.0	29.0
244	27.0	TC	6.77	6.77	6.77	6.83	6.97	6.97	6.97	6.97	7.17	7.17	7.17	7.17	7.72	7.72	7.72	7.72	
		S/T	0.71	0.74	0.83	0.91	0.64	0.67	0.75	0.84	0.57	0.60	0.68	0.76	0.41	0.44	0.51	0.59	
		PI	1.64	1.64	1.64	1.64	1.64	1.64	1.64	1.64	1.64	1.64	1.64	1.64	1.64	1.64	1.64	1.64	
	30.0	TC	6.57	6.57	6.57	6.63	6.77	6.77	6.77	6.77	6.97	6.97	6.97	6.97	7.52	7.52	7.52	7.52	
		S/T	0.72	0.75	0.84	0.92	0.65	0.67	0.76	0.85	0.58	0.60	0.69	0.77	0.41	0.44	0.51	0.59	
		PI	1.72	1.72	1.72	1.72	1.73	1.73	1.73	1.73	1.73	1.73	1.73	1.73	1.73	1.73	1.73	1.73	
	32.0	TC	6.43	6.43	6.43	6.49	6.63	6.63	6.63	6.63	6.86	6.86	6.86	6.86	7.38	7.38	7.38	7.38	
		S/T	0.72	0.75	0.84	0.93	0.65	0.68	0.77	0.85	0.58	0.60	0.69	0.77	0.41	0.44	0.52	0.60	
		PI	1.79	1.79	1.79	1.79	1.79	1.79	1.79	1.79	1.79	1.79	1.79	1.79	1.80	1.80	1.80	1.80	
	35.0	TC	6.26	6.26	6.26	6.31	6.43	6.43	6.43	6.43	6.63	6.63	6.63	6.63	7.17	7.17	7.17	7.17	
		S/T	0.73	0.76	0.85	0.94	0.65	0.68	0.77	0.87	0.58	0.61	0.69	0.79	0.41	0.44	0.52	0.60	
		PI	1.89	1.89	1.89	1.89	1.89	1.89	1.89	1.89	1.90	1.90	1.90	1.90	1.91	1.91	1.91	1.91	
	43.0	TC	5.80	5.80	5.84	5.90	5.98	5.98	5.98	6.02	6.18	6.18	6.21	6.18	6.67	6.67	6.67	6.67	
		S/T	0.75	0.79	0.89	0.98	0.67	0.70	0.80	0.90	0.59	0.62	0.72	0.82	0.41	0.44	0.53	0.62	
		PI	2.24	2.24	2.24	2.24	2.25	2.25	2.25	2.25	2.25	2.25	2.25	2.25	2.27	2.27	2.27	2.27	
	46.0	TC	5.65	5.65	5.71	5.77	5.83	5.83	5.83	5.88	6.03	6.03	6.03	6.03	6.51	6.51	6.51	6.51	
		S/T	0.77	0.80	0.90	1.00	0.68	0.71	0.82	0.92	0.60	0.63	0.73	0.83	0.41	0.44	0.53	0.63	
		PI	2.37	2.37	2.37	2.37	2.38	2.38	2.38	2.38	2.38	2.38	2.38	2.38	2.40	2.40	2.40	2.40	
	52.0	TC	4.90	4.90	4.95	5.01	5.07	5.07	5.07	5.12	5.24	5.24	5.24	5.24	5.69	5.69	5.69	5.69	
		S/T	0.80	0.83	0.95	1.00	0.70	0.74	0.85	0.96	0.61	0.65	0.76	0.87	0.41	0.44	0.54	0.65	
		PI	2.62	2.62	2.62	2.62	2.62	2.62	2.62	2.62	2.63	2.63	2.63	2.63	2.65	2.65	2.65	2.65	
	306	27.0	TC	6.92	6.92	6.98	7.03	7.12	7.12	7.12	7.18	7.32	7.32	7.32	7.32	7.90	7.90	7.90	7.90
			S/T	0.76	0.79	0.90	1.00	0.68	0.71	0.81	0.91	0.60	0.63	0.73	0.83	0.41	0.44	0.53	0.63
			PI	1.67	1.67	1.67	1.67	1.67	1.67	1.67	1.67	1.68	1.68	1.68	1.68	1.68	1.68	1.68	1.68
30.0		TC	6.72	6.72	6.78	6.83	6.92	6.92	6.92	6.98	7.12	7.12	7.12	7.12	7.69	7.69	7.69	7.69	
		S/T	0.77	0.80	0.91	1.00	0.68	0.72	0.82	0.93	0.60	0.63	0.74	0.84	0.41	0.44	0.54	0.63	
		PI	1.76	1.76	1.76	1.76	1.76	1.76	1.76	1.76	1.76	1.76	1.76	1.76	1.77	1.77	1.77	1.77	
32.0		TC	6.57	6.57	6.63	6.69	6.78	6.78	6.78	6.83	7.01	7.01	7.01	7.01	7.55	7.55	7.55	7.55	
		S/T	0.78	0.81	0.92	1.00	0.69	0.72	0.83	0.93	0.60	0.64	0.74	0.85	0.41	0.44	0.54	0.64	
		PI	1.83	1.83	1.83	1.83	1.83	1.83	1.83	1.83	1.83	1.83	1.83	1.83	1.84	1.84	1.84	1.84	
35.0		TC	6.37	6.37	6.43	6.49	6.57	6.57	6.57	6.63	6.78	6.78	6.89	6.78	7.32	7.32	7.32	7.32	
		S/T	0.79	0.82	0.93	1.00	0.70	0.73	0.84	0.95	0.61	0.64	0.75	0.86	0.41	0.44	0.54	0.64	
		PI	1.93	1.93	1.93	1.93	1.93	1.93	1.93	1.93	1.94	1.94	1.94	1.94	1.94	1.94	1.94	1.94	
43.0		TC	5.98	5.98	6.04	6.10	6.16	6.16	6.21	6.27	6.37	6.37	6.40	6.41	6.89	6.89	6.89	6.89	
		S/T	0.82	0.86	0.98	1.00	0.72	0.75	0.88	1.00	0.62	0.66	0.78	0.89	0.41	0.45	0.56	0.67	
		PI	2.29	2.29	2.29	2.29	2.29	2.29	2.29	2.29	2.30	2.30	2.30	2.30	2.31	2.31	2.31	2.31	
46.0		TC	5.82	5.82	5.88	5.94	6.00	6.00	6.06	6.12	6.21	6.21	6.21	6.27	6.73	6.73	6.73	6.73	
		S/T	0.83	0.87	1.00	1.00	0.73	0.77	0.89	1.00	0.63	0.67	0.79	0.91	0.41	0.45	0.56	0.68	
		PI	2.42	2.42	2.42	2.42	2.42	2.42	2.42	2.42	2.43	2.43	2.43	2.43	2.45	2.45	2.45	2.45	
52.0		TC	5.06	5.12	5.18	5.23	5.23	5.23	5.29	5.35	5.41	5.41	5.41	5.46	5.87	5.87	5.87	5.87	
		S/T	0.87	0.91	1.00	1.00	0.76	0.80	0.94	1.00	0.65	0.69	0.83	0.96	0.42	0.45	0.58	0.91	
		PI	2.67	2.67	2.67	2.67	2.67	2.67	2.67	2.67	2.68	2.68	2.68	2.68	2.70	2.70	2.70	2.70	
379		27.0	TC	7.06	7.06	7.12	7.18	7.26	7.26	7.35	7.44	7.49	7.49	7.49	7.58	8.07	8.07	8.07	8.07
			S/T	0.82	0.86	0.99	1.00	0.72	0.76	0.88	1.00	0.63	0.67	0.79	0.91	0.41	0.45	0.56	0.67
			PI	1.71	1.71	1.71	1.71	1.71	1.71	1.71	1.71	1.71	1.71	1.71	1.71	1.71	1.71	1.71	1.71
	30.0	TC	6.86	6.86	6.92	6.98	7.06	7.06	7.12	7.18	7.29	7.29	7.29	7.38	7.84	7.84	7.84	7.84	
		S/T	0.83	0.87	1.00	1.00	0.73	0.77	0.90	1.00	0.64	0.67	0.80	0.92	0.41	0.45	0.57	0.68	
		PI	1.80	1.80	1.80	1.80	1.80	1.80	1.80	1.80	1.80	1.80	1.80	1.80	1.81	1.81	1.81	1.81	
	32.0	TC	6.72	6.72	6.78	6.83	6.92	6.92	6.98	7.03	7.15	7.15	7.15	7.21	7.69	7.69	7.69	7.69	
		S/T	0.84	0.88	1.00	1.00	0.74	0.78	0.91	1.00	0.64	0.68	0.81	0.93	0.41	0.45	0.57	0.69	
		PI	1.86	1.86	1.86	1.86	1.87	1.87	1.87	1.87	1.87	1.87	1.87	1.87	1.88	1.88	1.88	1.88	
	35.0	TC	6.52	6.57	6.63	6.69	6.72	6.72	6.78	6.83	6.92	6.92	7.03	7.09	7.46	7.46	7.46	7.46	
		S/T	0.85	0.89	1.00	1.00	0.75	0.79	0.92	1.00	0.65	0.69	0.81	0.94	0.41	0.45	0.57	0.70	
		PI	1.97	1.97	1.97	1.97	1.97	1.97	1.97	1.97	1.98	1.98	1.98	1.98	1.99	1.99	1.99	1.99	
	43.0	TC	6.10	6.16	6.22	6.28	6.31	6.31	6.37	6.43	6.50	6.50	6.53	6.59	7.04	7.04	7.04	7.04	
		S/T	0.89	0.94	1.00	1.00	0.78	0.82	0.97	1.00	0.67	0.71	0.86	1.00	0.42	0.46	0.59	0.90	
		PI	2.33	2.33	2.33	2.33	2.33	2.33	2.33	2.33	2.34	2.34	2.34	2.34	2.36	2.36	2.36	2.36	
	46.0	TC	5.94	6.00	6.06	6.12	6.15	6.15	6.21	6.27	6.34	6.34	6.34	6.40	6.88	6.88	6.88	6.88	
		S/T	0.91	0.96	1.00	1.00	0.79	0.84	0.99	1.00	0.68	0.72	0.87	1.00	0.42	0.46	0.60	0.92	
		PI	2.47	2.47	2.47	2.47	2.47	2.47	2.47	2.47	2.48	2.48	2.48	2.48	2.50	2.50	2.50	2.50	
	52.0	TC	5.18	5.23	5.29	5.35	5.35	5.35	5.41	5.46	5.52	5.52	5.58	5.64	5.98	5.98	5.98	5.98	
		S/T	0.96	1.00	1.00	1.00	0.83	0.88	1.00	1.00	0.70	0.75	0.92	1.00	0.42	0.47	0.62	0.97	
		PI	2.72	2.72	2.72	2.72	2.73	2.73	2.73	2.73	2.74	2.74	2.74	2.74	2.76	2.76	2.76	2.76	

TC: Total Capacity(kW)

S/T: Sensible Capacity ratio

PI: Power Input(kW)

Note: Above deration table showing the data was simulated basing on a fixed compressor speed.

42QSM030VSP+38QST030VS																			
INDOOR AIRFLOW (L/S)	OUTDOOR DB (°C)	ID WB (°C)	17.2				18.0				19.0				22.0				
			ID DB (°C)	24.4	25.0	27.0	29.0	24.4	25.0	27.0	29.0	24.4	25.0	27.0	29.0	24.4	25.0	27.0	29.0
275	27.0	TC	8.77	8.77	8.77	8.77	9.02	9.02	9.02	9.02	9.31	9.31	9.31	9.31	10.00	10.00	10.00	10.00	
		S/T	0.69	0.71	0.79	0.86	0.62	0.65	0.72	0.79	0.56	0.58	0.65	0.73	0.42	0.44	0.50	0.57	
		PI	2.05	2.05	2.05	2.05	2.05	2.05	2.05	2.05	2.05	2.05	2.05	2.05	2.06	2.06	2.06	2.06	
	30.0	TC	8.51	8.51	8.51	8.51	8.77	8.77	8.77	8.77	9.05	9.05	9.05	9.05	9.74	9.74	9.74	9.74	
		S/T	0.69	0.72	0.80	0.87	0.63	0.65	0.73	0.80	0.56	0.59	0.66	0.73	0.42	0.44	0.51	0.57	
		PI	2.17	2.17	2.17	2.17	2.17	2.17	2.17	2.17	2.17	2.17	2.17	2.17	2.18	2.18	2.18	2.18	
	32.0	TC	8.33	8.33	8.33	8.33	8.59	8.59	8.59	8.59	8.88	8.88	8.88	8.88	9.57	9.57	9.57	9.57	
		S/T	0.70	0.72	0.80	0.88	0.63	0.65	0.73	0.81	0.57	0.59	0.66	0.74	0.42	0.44	0.51	0.58	
		PI	2.24	2.24	2.24	2.24	2.24	2.24	2.24	2.24	2.25	2.25	2.25	2.25	2.26	2.26	2.26	2.26	
	35.0	TC	8.08	8.08	8.08	8.16	8.33	8.33	8.33	8.33	8.59	8.59	8.74	8.59	9.28	9.28	9.28	9.28	
		S/T	0.70	0.73	0.81	0.89	0.63	0.66	0.74	0.82	0.57	0.59	0.66	0.75	0.41	0.44	0.51	0.58	
		PI	2.37	2.37	2.37	2.37	2.37	2.37	2.37	2.37	2.38	2.38	2.38	2.38	2.39	2.39	2.39	2.39	
	43.0	TC	7.46	7.46	7.46	7.53	7.71	7.71	7.71	7.71	7.95	7.95	7.99	7.95	8.61	8.61	8.61	8.61	
		S/T	0.72	0.75	0.84	0.92	0.65	0.67	0.76	0.85	0.58	0.60	0.69	0.77	0.41	0.44	0.51	0.59	
		PI	2.81	2.81	2.81	2.81	2.81	2.81	2.81	2.81	2.82	2.82	2.82	2.82	2.84	2.84	2.84	2.84	
	46.0	TC	7.23	7.23	7.23	7.29	7.47	7.47	7.47	7.47	7.70	7.70	7.70	7.70	8.35	8.35	8.35	8.35	
		S/T	0.73	0.76	0.85	0.94	0.65	0.68	0.77	0.86	0.58	0.61	0.69	0.78	0.41	0.44	0.52	0.60	
		PI	2.97	2.97	2.97	2.97	2.97	2.97	2.97	2.97	2.98	2.98	2.98	2.98	3.01	3.01	3.01	3.01	
	52.0	TC	6.41	6.41	6.47	6.53	6.61	6.61	6.61	6.67	6.84	6.84	6.84	6.84	7.42	7.42	7.42	7.42	
		S/T	0.75	0.79	0.89	0.98	0.67	0.70	0.80	0.90	0.59	0.62	0.72	0.82	0.41	0.44	0.53	0.62	
		PI	3.28	3.28	3.28	3.28	3.29	3.29	3.29	3.29	3.29	3.29	3.29	3.29	3.32	3.32	3.32	3.32	
	336	27.0	TC	8.94	8.94	8.94	9.03	9.20	9.20	9.20	9.20	9.49	9.49	9.49	9.49	10.21	10.21	10.21	10.21
			S/T	0.72	0.75	0.84	0.93	0.65	0.67	0.76	0.85	0.58	0.60	0.69	0.77	0.41	0.44	0.52	0.60
			PI	2.09	2.09	2.09	2.09	2.09	2.09	2.09	2.09	2.10	2.10	2.10	2.10	2.10	2.10	2.10	2.10
30.0		TC	8.68	8.68	8.68	8.77	8.94	8.94	8.94	8.94	9.23	9.23	9.23	9.23	9.95	9.95	9.95	9.95	
		S/T	0.73	0.76	0.85	0.94	0.65	0.68	0.77	0.86	0.58	0.61	0.69	0.78	0.41	0.44	0.52	0.60	
		PI	2.21	2.21	2.21	2.21	2.22	2.22	2.22	2.22	2.22	2.22	2.22	2.22	2.23	2.23	2.23	2.23	
32.0		TC	8.51	8.51	8.51	8.60	8.77	8.77	8.77	8.77	9.06	9.06	9.06	9.06	9.75	9.75	9.75	9.75	
		S/T	0.73	0.76	0.86	0.95	0.66	0.68	0.78	0.87	0.58	0.61	0.70	0.79	0.41	0.44	0.52	0.60	
		PI	2.29	2.29	2.29	2.29	2.29	2.29	2.29	2.29	2.29	2.29	2.29	2.29	2.31	2.31	2.31	2.31	
35.0		TC	8.25	8.25	8.25	8.34	8.51	8.51	8.51	8.51	8.77	8.77	8.91	8.77	9.46	9.46	9.46	9.46	
		S/T	0.74	0.77	0.87	0.96	0.66	0.69	0.79	0.88	0.59	0.61	0.70	0.80	0.41	0.44	0.52	0.61	
		PI	2.42	2.42	2.42	2.42	2.42	2.42	2.42	2.42	2.43	2.43	2.43	2.43	2.43	2.43	2.43	2.43	
43.0		TC	7.54	7.54	7.60	7.69	7.78	7.78	7.78	7.84	8.02	8.02	8.06	8.02	8.67	8.67	8.67	8.67	
		S/T	0.77	0.80	0.90	1.00	0.68	0.71	0.82	0.92	0.60	0.63	0.73	0.83	0.41	0.44	0.53	0.63	
		PI	2.86	2.86	2.86	2.86	2.86	2.86	2.86	2.86	2.86	2.86	2.86	2.86	2.89	2.89	2.89	2.89	
46.0		TC	7.30	7.30	7.39	7.48	7.54	7.54	7.54	7.62	7.77	7.77	7.77	7.77	8.41	8.41	8.41	8.41	
		S/T	0.78	0.81	0.92	1.00	0.69	0.72	0.83	0.93	0.60	0.64	0.74	0.85	0.41	0.44	0.54	0.64	
		PI	3.02	3.02	3.02	3.02	3.03	3.03	3.03	3.03	3.03	3.03	3.03	3.03	3.06	3.06	3.06	3.06	
52.0		TC	6.46	6.46	6.52	6.57	6.69	6.69	6.69	6.74	6.91	6.91	6.91	6.97	7.51	7.51	7.51	7.51	
		S/T	0.81	0.85	0.97	1.00	0.71	0.75	0.87	0.98	0.62	0.66	0.77	0.88	0.41	0.44	0.55	0.91	
		PI	3.34	3.34	3.34	3.34	3.34	3.34	3.34	3.34	3.35	3.35	3.35	3.35	3.38	3.38	3.38	3.38	
394		27.0	TC	9.11	9.11	9.20	9.29	9.40	9.40	9.40	9.49	9.66	9.66	9.66	9.66	10.41	10.41	10.41	10.41
			S/T	0.76	0.79	0.89	0.99	0.67	0.70	0.80	0.90	0.59	0.62	0.72	0.82	0.41	0.44	0.53	0.62
			PI	2.14	2.14	2.14	2.14	2.14	2.14	2.14	2.14	2.14	2.14	2.14	2.14	2.14	2.14	2.14	2.14
	30.0	TC	8.86	8.86	8.94	9.03	9.11	9.11	9.11	9.20	9.40	9.40	9.40	9.40	10.12	10.12	10.12	10.12	
		S/T	0.76	0.80	0.90	1.00	0.68	0.71	0.82	0.92	0.60	0.63	0.73	0.83	0.41	0.44	0.53	0.63	
		PI	2.25	2.25	2.25	2.25	2.25	2.25	2.25	2.25	2.25	2.25	2.25	2.25	2.26	2.26	2.26	2.26	
	32.0	TC	8.68	8.68	8.77	8.86	8.94	8.94	8.94	9.03	9.23	9.23	9.23	9.23	9.95	9.95	9.95	9.95	
		S/T	0.77	0.80	0.91	1.00	0.68	0.72	0.82	0.92	0.60	0.63	0.73	0.84	0.41	0.44	0.54	0.63	
		PI	2.33	2.33	2.33	2.33	2.34	2.34	2.34	2.34	2.34	2.34	2.34	2.34	2.35	2.35	2.35	2.35	
	35.0	TC	8.42	8.42	8.51	8.60	8.68	8.68	8.68	8.77	8.94	8.94	9.09	8.94	9.66	9.66	9.66	9.66	
		S/T	0.78	0.81	0.92	1.00	0.69	0.72	0.83	0.94	0.61	0.64	0.74	0.85	0.41	0.44	0.54	0.64	
		PI	2.47	2.47	2.47	2.47	2.47	2.47	2.47	2.47	2.48	2.48	2.48	2.48	2.49	2.49	2.49	2.49	
	43.0	TC	7.67	7.67	7.76	7.84	7.93	7.93	7.99	8.08	8.17	8.17	8.21	8.23	8.85	8.85	8.85	8.85	
		S/T	0.81	0.85	0.97	1.00	0.71	0.75	0.87	0.99	0.62	0.66	0.77	0.89	0.41	0.44	0.55	0.90	
		PI	2.91	2.91	2.91	2.91	2.92	2.92	2.92	2.92	2.93	2.93	2.93	2.93	2.95	2.95	2.95	2.95	
	46.0	TC	7.42	7.42	7.51	7.59	7.68	7.68	7.77	7.86	7.91	7.91	7.91	8.00	8.58	8.58	8.58	8.58	
		S/T	0.82	0.86	0.99	1.00	0.72	0.76	0.88	1.00	0.63	0.67	0.79	0.90	0.41	0.45	0.56	0.92	
		PI	3.08	3.08	3.08	3.08	3.09	3.09	3.09	3.09	3.10	3.10	3.10	3.10	3.12	3.12	3.12	3.12	
	52.0	TC	6.60	6.66	6.72	6.77	6.80	6.80	6.86	6.91	7.06	7.06	7.06	7.11	7.65	7.65	7.65	7.65	
		S/T	0.86	0.90	1.00	1.00	0.75	0.79	0.93	1.00	0.65	0.69	0.82	0.95	0.41	0.45	0.58	0.97	
		PI	3.41	3.41	3.41	3.41	3.41	3.41	3.41	3.41	3.42	3.42	3.42	3.42	3.45	3.45	3.45	3.45	

TC: Total Capacity(kW)

S/T: Sensible Capacity ratio

PI: Power Input(kW)

Note: Above deration table showing the data was simulated basing on a fixed compressor speed.

42QSM036VSP+38QST036VS																			
INDOOR AIRFLOW (L/S)	OUTDOOR DB (°C)	ID WB (°C)	17.2				18.0				19.0				22.0				
			ID DB (°C)	24.4	25.0	27.0	29.0	24.4	25.0	27.0	29.0	24.4	25.0	27.0	29.0	24.4	25.0	27.0	29.0
378	27.0	TC	10.29	10.29	10.29	10.41	10.61	10.61	10.61	10.61	10.92	10.92	10.92	10.92	11.76	11.76	11.76	11.76	
		S/T	0.72	0.74	0.83	0.92	0.64	0.67	0.76	0.84	0.57	0.60	0.68	0.77	0.41	0.44	0.51	0.59	
		PI	2.43	2.43	2.43	2.43	2.43	2.43	2.43	2.43	2.43	2.43	2.43	2.43	2.44	2.44	2.44	2.44	
	30.0	TC	10.00	10.00	10.00	10.09	10.32	10.32	10.32	10.32	10.61	10.61	10.61	10.61	11.44	11.44	11.44	11.44	
		S/T	0.72	0.75	0.84	0.93	0.65	0.68	0.76	0.85	0.58	0.60	0.69	0.78	0.41	0.44	0.52	0.60	
		PI	2.57	2.57	2.57	2.57	2.57	2.57	2.57	2.57	2.57	2.57	2.57	2.57	2.58	2.58	2.58	2.58	
	32.0	TC	9.80	9.80	9.80	9.89	10.12	10.12	10.12	10.12	10.41	10.41	10.41	10.41	11.24	11.24	11.24	11.24	
		S/T	0.73	0.76	0.85	0.94	0.65	0.68	0.77	0.86	0.58	0.61	0.69	0.78	0.41	0.44	0.52	0.60	
		PI	2.65	2.65	2.65	2.65	2.66	2.66	2.66	2.66	2.66	2.66	2.66	2.66	2.68	2.68	2.68	2.68	
	35.0	TC	9.51	9.51	9.51	9.60	9.80	9.80	9.80	9.80	10.12	10.12	10.12	10.12	10.89	10.89	10.89	10.89	
		S/T	0.74	0.76	0.86	0.95	0.66	0.69	0.78	0.87	0.58	0.61	0.70	0.79	0.41	0.44	0.52	0.60	
		PI	2.80	2.80	2.80	2.80	2.81	2.81	2.81	2.81	2.82	2.82	2.82	2.82	2.83	2.83	2.83	2.83	
	43.0	TC	8.71	8.71	8.77	8.86	8.98	8.98	8.98	9.04	9.27	9.27	9.31	9.27	10.01	10.01	10.01	10.01	
		S/T	0.76	0.79	0.89	0.99	0.67	0.71	0.81	0.91	0.59	0.62	0.72	0.82	0.41	0.44	0.53	0.62	
		PI	3.32	3.32	3.32	3.32	3.33	3.33	3.33	3.33	3.34	3.34	3.34	3.34	3.35	3.35	3.35	3.35	
	46.0	TC	8.44	8.44	8.52	8.61	8.70	8.70	8.70	8.79	8.99	8.99	8.99	8.99	9.72	9.72	9.72	9.72	
		S/T	0.77	0.80	0.91	1.00	0.68	0.72	0.82	0.92	0.60	0.63	0.73	0.84	0.41	0.44	0.53	0.63	
		PI	3.51	3.51	3.51	3.51	3.52	3.52	3.52	3.52	3.53	3.53	3.53	3.53	3.55	3.55	3.55	3.55	
	52.0	TC	7.46	7.46	7.55	7.63	7.72	7.72	7.72	7.80	7.97	7.97	7.97	7.97	8.66	8.66	8.66	8.66	
		S/T	0.80	0.84	0.95	1.00	0.71	0.74	0.86	0.97	0.62	0.65	0.76	0.88	0.41	0.44	0.55	0.65	
		PI	3.89	3.89	3.89	3.89	3.90	3.90	3.90	3.90	3.91	3.91	3.91	3.91	3.94	3.94	3.94	3.94	
	522	27.0	TC	10.50	10.50	10.61	10.73	10.81	10.81	10.81	10.93	11.13	11.13	11.13	11.13	11.99	11.99	11.99	11.99
			S/T	0.80	0.83	0.95	1.00	0.70	0.74	0.86	0.97	0.62	0.65	0.76	0.88	0.41	0.44	0.55	0.65
			PI	2.48	2.48	2.48	2.48	2.48	2.48	2.48	2.48	2.48	2.48	2.48	2.48	2.49	2.49	2.49	2.49
30.0		TC	10.21	10.21	10.32	10.44	10.52	10.52	10.52	10.64	10.84	10.84	10.84	10.96	11.67	11.67	11.67	11.67	
		S/T	0.81	0.84	0.96	1.00	0.71	0.75	0.87	0.98	0.62	0.66	0.77	0.88	0.41	0.44	0.55	0.66	
		PI	2.62	2.62	2.62	2.62	2.63	2.63	2.63	2.63	2.63	2.63	2.63	2.63	2.64	2.64	2.64	2.64	
32.0		TC	10.01	10.01	10.09	10.21	10.29	10.29	10.29	10.41	10.61	10.61	10.61	10.73	11.44	11.44	11.44	11.44	
		S/T	0.81	0.85	0.97	1.00	0.72	0.75	0.88	0.99	0.62	0.66	0.78	0.89	0.41	0.45	0.56	0.67	
		PI	2.71	2.71	2.71	2.71	2.71	2.71	2.71	2.71	2.72	2.72	2.72	2.72	2.73	2.73	2.73	2.73	
35.0		TC	9.69	9.69	9.78	9.86	10.01	10.01	10.09	10.21	10.29	10.29	10.47	10.58	11.13	11.13	11.13	11.13	
		S/T	0.83	0.86	0.99	1.00	0.73	0.76	0.89	1.00	0.63	0.67	0.78	0.90	0.41	0.45	0.56	0.67	
		PI	2.86	2.86	2.86	2.86	2.87	2.87	2.87	2.87	2.88	2.88	2.88	2.88	2.88	2.88	2.88	2.88	
43.0		TC	8.87	8.93	9.02	9.10	9.16	9.16	9.25	9.35	9.45	9.45	9.50	9.60	10.23	10.23	10.23	10.23	
		S/T	0.86	0.90	1.00	1.00	0.75	0.79	0.93	1.00	0.65	0.69	0.82	0.95	0.41	0.45	0.58	0.70	
		PI	3.39	3.39	3.39	3.39	3.39	3.39	3.39	3.39	3.40	3.40	3.40	3.40	3.43	3.43	3.43	3.43	
46.0		TC	8.59	8.68	8.77	8.85	8.88	8.88	8.97	9.06	9.17	9.17	9.17	9.26	9.93	9.93	9.93	9.93	
		S/T	0.88	0.92	1.00	1.00	0.77	0.81	0.95	1.00	0.66	0.70	0.84	0.98	0.42	0.45	0.58	0.71	
		PI	3.58	3.58	3.58	3.58	3.59	3.59	3.59	3.59	3.60	3.60	3.60	3.60	3.63	3.63	3.63	3.63	
52.0		TC	7.61	7.69	7.78	7.87	7.87	7.87	7.95	8.04	8.12	8.12	8.12	8.21	8.83	8.83	8.83	8.83	
		S/T	0.92	0.97	1.00	1.00	0.80	0.85	1.00	1.00	0.68	0.73	0.88	1.00	0.42	0.46	0.60	0.91	
		PI	3.97	3.97	3.97	3.97	3.98	3.98	3.98	3.98	3.99	3.99	3.99	3.99	4.02	4.02	4.02	4.02	
625		27.0	TC	10.70	10.81	10.93	11.04	11.01	11.01	11.13	11.24	11.36	11.36	11.36	11.47	12.22	12.22	12.22	12.22
			S/T	0.86	0.89	1.00	1.00	0.75	0.79	0.92	1.00	0.65	0.69	0.82	0.95	0.41	0.45	0.58	0.70
			PI	2.53	2.53	2.53	2.53	2.53	2.53	2.53	2.53	2.53	2.53	2.53	2.53	2.54	2.54	2.54	2.54
	30.0	TC	10.38	10.50	10.61	10.73	10.73	10.73	10.84	10.96	11.04	11.04	11.04	11.16	11.90	11.90	11.90	11.90	
		S/T	0.87	0.91	1.00	1.00	0.76	0.80	0.94	1.00	0.65	0.70	0.83	0.96	0.42	0.45	0.58	0.71	
		PI	2.68	2.68	2.68	2.68	2.68	2.68	2.68	2.68	2.68	2.68	2.68	2.68	2.69	2.69	2.69	2.69	
	32.0	TC	10.18	10.29	10.41	10.52	10.50	10.50	10.61	10.73	10.84	10.84	10.84	10.96	11.67	11.67	11.67	11.67	
		S/T	0.88	0.92	1.00	1.00	0.76	0.81	0.95	1.00	0.66	0.70	0.84	0.97	0.42	0.45	0.58	0.71	
		PI	2.77	2.77	2.77	2.77	2.77	2.77	2.77	2.77	2.78	2.78	2.78	2.78	2.79	2.79	2.79	2.79	
	35.0	TC	9.89	9.98	10.06	10.18	10.18	10.18	10.29	10.41	10.50	10.50	10.67	10.78	11.33	11.33	11.33	11.33	
		S/T	0.89	0.93	1.00	1.00	0.77	0.82	0.96	1.00	0.67	0.71	0.85	0.98	0.42	0.46	0.59	0.72	
		PI	2.92	2.92	2.92	2.92	2.93	2.93	2.93	2.93	2.94	2.94	2.94	2.94	2.96	2.96	2.96	2.96	
	43.0	TC	9.05	9.14	9.22	9.32	9.34	9.34	9.43	9.53	9.64	9.64	9.75	9.84	10.41	10.41	10.41	10.41	
		S/T	0.93	0.98	1.00	1.00	0.81	0.86	1.00	1.00	0.69	0.74	0.89	1.00	0.42	0.46	0.61	0.90	
		PI	3.45	3.45	3.45	3.45	3.46	3.46	3.46	3.46	3.47	3.47	3.47	3.47	3.50	3.50	3.50	3.50	
	46.0	TC	8.77	8.85	8.94	9.03	9.06	9.06	9.15	9.23	9.35	9.35	9.44	9.53	10.11	10.11	10.11	10.11	
		S/T	0.95	1.00	1.00	1.00	0.82	0.87	1.00	1.00	0.70	0.75	0.91	1.00	0.42	0.47	0.62	0.92	
		PI	3.65	3.65	3.65	3.65	3.66	3.66	3.66	3.66	3.67	3.67	3.67	3.67	3.70	3.70	3.70	3.70	
	52.0	TC	7.75	7.84	7.92	8.01	8.01	8.09	8.18	8.26	8.29	8.29	8.38	8.46	8.98	8.98	8.98	8.98	
		S/T	1.00	1.00	1.00	1.00	0.86	0.92	1.00	1.00	0.73	0.78	0.96	1.00	0.43	0.48	0.64	0.97	
		PI	4.05	4.05	4.05	4.05	4.06	4.06	4.06	4.06	4.07	4.07	4.07	4.07	4.10	4.10	4.10	4.10	

TC: Total Capacity(kW)

S/T: Sensible Capacity ratio

PI: Power Input(kW)

Note: Above deration table showing the data was simulated basing on a fixed compressor speed.

42QSM048VT+38QST048VT																			
INDOOR AIRFLOW (L/S)	OUTDOOR DB (°C)	ID WB (°C)	17.2				18.0				19.0				22.0				
			ID DB (°C)	24.4	25.0	27.0	29.0	24.4	25.0	27.0	29.0	24.4	25.0	27.0	29.0	24.4	25.0	27.0	29.0
550	27.0	TC	13.52	13.52	13.52	13.66	13.95	13.95	13.95	13.95	14.35	14.35	14.35	14.35	15.47	15.47	15.47	15.47	
		S/T	0.74	0.77	0.87	0.96	0.66	0.69	0.78	0.88	0.59	0.61	0.71	0.80	0.41	0.44	0.52	0.61	
		PI	3.30	3.30	3.30	3.30	3.30	3.30	3.30	3.30	3.31	3.31	3.31	3.31	3.31	3.31	3.31	3.31	3.31
	30.0	TC	13.14	13.14	13.14	13.29	13.55	13.55	13.55	13.69	13.95	13.95	13.95	13.95	15.04	15.04	15.04	15.04	
		S/T	0.75	0.78	0.88	0.97	0.67	0.70	0.79	0.89	0.59	0.62	0.71	0.81	0.41	0.44	0.53	0.61	
		PI	3.49	3.49	3.49	3.49	3.50	3.50	3.50	3.50	3.50	3.50	3.50	3.50	3.52	3.52	3.52	3.52	
	32.0	TC	12.89	12.89	13.00	13.14	13.29	13.29	13.29	13.43	13.69	13.69	13.69	13.69	14.75	14.75	14.75	14.75	
		S/T	0.75	0.78	0.88	0.98	0.67	0.70	0.80	0.90	0.59	0.62	0.72	0.81	0.41	0.44	0.53	0.62	
		PI	3.62	3.62	3.62	3.62	3.63	3.63	3.63	3.63	3.64	3.64	3.64	3.64	3.65	3.65	3.65	3.65	
	35.0	TC	12.48	12.48	12.60	12.71	12.89	12.89	12.89	13.00	13.29	13.29	13.29	13.29	14.32	14.32	14.32	14.32	
		S/T	0.76	0.79	0.90	1.00	0.68	0.71	0.81	0.91	0.60	0.63	0.72	0.83	0.41	0.44	0.53	0.62	
		PI	3.82	3.82	3.82	3.82	3.83	3.83	3.83	3.83	3.83	3.83	3.84	3.83	3.86	3.86	3.86	3.86	
	43.0	TC	11.80	11.80	11.92	12.04	12.17	12.17	12.17	12.29	12.57	12.57	12.62	12.57	13.60	13.60	13.60	13.60	
		S/T	0.79	0.82	0.94	1.00	0.70	0.73	0.84	0.95	0.61	0.64	0.75	0.86	0.41	0.44	0.54	0.64	
		PI	4.59	4.59	4.59	4.59	4.60	4.60	4.60	4.60	4.60	4.60	4.61	4.60	4.64	4.64	4.64	4.64	
	46.0	TC	11.59	11.59	11.71	11.84	11.96	11.96	11.96	12.08	12.35	12.35	12.35	12.35	13.39	13.39	13.39	13.39	
		S/T	0.80	0.84	0.96	1.00	0.71	0.74	0.86	0.97	0.62	0.65	0.77	0.88	0.41	0.44	0.55	0.65	
		PI	4.87	4.87	4.87	4.87	4.88	4.88	4.88	4.88	4.89	4.89	4.89	4.89	4.94	4.94	4.94	4.94	
	52.0	TC	9.77	9.77	9.85	9.94	10.11	10.11	10.22	10.34	10.45	10.45	10.45	10.56	11.36	11.36	11.36	11.36	
		S/T	0.84	0.88	1.00	1.00	0.73	0.77	0.90	1.00	0.64	0.67	0.80	0.92	0.41	0.45	0.56	0.68	
		PI	5.29	5.29	5.29	5.29	5.30	5.30	5.30	5.30	5.32	5.32	5.32	5.32	5.36	5.36	5.36	5.36	
	675	27.0	TC	13.81	13.81	13.95	14.10	14.24	14.24	14.24	14.38	14.67	14.67	14.67	14.67	15.79	15.79	15.79	15.79
			S/T	0.79	0.83	0.94	1.00	0.70	0.73	0.85	0.96	0.61	0.65	0.76	0.87	0.41	0.44	0.55	0.65
			PI	3.37	3.37	3.37	3.37	3.37	3.37	3.37	3.37	3.37	3.37	3.37	3.37	3.38	3.38	3.38	3.38
30.0		TC	13.44	13.44	13.58	13.72	13.84	13.84	13.84	13.98	14.27	14.27	14.27	14.27	15.36	15.36	15.36	15.36	
		S/T	0.80	0.84	0.95	1.00	0.71	0.74	0.86	0.97	0.62	0.65	0.77	0.88	0.41	0.44	0.55	0.66	
		PI	3.57	3.57	3.57	3.57	3.57	3.57	3.57	3.57	3.57	3.57	3.57	3.57	3.59	3.59	3.59	3.59	
32.0		TC	13.15	13.15	13.29	13.44	13.58	13.58	13.58	13.72	13.98	13.98	13.98	14.13	15.07	15.07	15.07	15.07	
		S/T	0.81	0.85	0.96	1.00	0.71	0.75	0.87	0.98	0.62	0.66	0.77	0.88	0.41	0.44	0.55	0.66	
		PI	3.70	3.70	3.70	3.70	3.70	3.70	3.70	3.70	3.71	3.71	3.71	3.71	3.73	3.73	3.73	3.73	
35.0		TC	12.75	12.75	12.86	12.98	13.15	13.15	13.15	13.29	13.58	13.58	13.78	13.92	14.64	14.64	14.64	14.64	
		S/T	0.82	0.86	0.98	1.00	0.72	0.76	0.88	1.00	0.63	0.66	0.78	0.89	0.41	0.45	0.56	0.67	
		PI	3.90	3.90	3.90	3.90	3.91	3.91	3.91	3.91	3.91	3.91	3.92	3.91	3.91	3.91	3.91	3.91	
43.0		TC	12.09	12.17	12.29	12.41	12.48	12.48	12.57	12.70	12.89	12.89	12.94	13.07	13.93	13.93	13.93	13.93	
		S/T	0.85	0.89	1.00	1.00	0.75	0.79	0.92	1.00	0.65	0.68	0.82	0.94	0.41	0.45	0.57	0.69	
		PI	4.68	4.68	4.68	4.68	4.69	4.69	4.69	4.69	4.70	4.70	4.70	4.70	4.73	4.73	4.73	4.73	
46.0		TC	11.87	12.00	12.12	12.24	12.27	12.27	12.39	12.52	12.67	12.67	12.67	12.79	13.71	13.71	13.71	13.71	
		S/T	0.87	0.91	1.00	1.00	0.76	0.80	0.94	1.00	0.65	0.70	0.83	0.97	0.42	0.45	0.58	0.71	
		PI	4.98	4.98	4.98	4.98	4.99	4.99	4.99	4.99	5.00	5.00	5.00	5.00	5.04	5.04	5.04	5.04	
52.0		TC	10.03	10.14	10.26	10.37	10.37	10.37	10.48	10.60	10.71	10.71	10.71	10.83	11.62	11.62	11.62	11.62	
		S/T	0.91	0.96	1.00	1.00	0.79	0.84	0.99	1.00	0.68	0.72	0.87	1.00	0.42	0.46	0.60	0.91	
		PI	5.40	5.40	5.40	5.40	5.41	5.41	5.41	5.41	5.43	5.43	5.43	5.43	5.47	5.47	5.47	5.47	
792		27.0	TC	14.10	14.10	14.24	14.38	14.53	14.53	14.67	14.81	14.99	14.99	14.99	15.13	16.14	16.14	16.14	16.14
			S/T	0.84	0.88	1.00	1.00	0.74	0.78	0.90	1.00	0.64	0.68	0.80	0.93	0.41	0.45	0.57	0.69
			PI	3.44	3.44	3.44	3.44	3.44	3.44	3.44	3.44	3.44	3.44	3.44	3.44	3.45	3.45	3.45	3.45
	30.0	TC	13.69	13.84	13.98	14.13	14.13	14.13	14.27	14.41	14.56	14.56	14.56	14.70	15.68	15.68	15.68	15.68	
		S/T	0.85	0.89	1.00	1.00	0.75	0.79	0.92	1.00	0.64	0.68	0.82	0.94	0.41	0.45	0.57	0.70	
		PI	3.64	3.64	3.64	3.64	3.64	3.64	3.64	3.64	3.65	3.65	3.65	3.65	3.66	3.66	3.66	3.66	
	32.0	TC	13.44	13.58	13.72	13.87	13.87	13.87	14.01	14.15	14.27	14.27	14.27	14.41	15.39	15.39	15.39	15.39	
		S/T	0.86	0.90	1.00	1.00	0.75	0.79	0.93	1.00	0.65	0.69	0.82	0.95	0.41	0.45	0.58	0.70	
		PI	3.76	3.76	3.76	3.76	3.77	3.77	3.77	3.77	3.78	3.78	3.78	3.78	3.80	3.80	3.80	3.80	
	35.0	TC	13.03	13.18	13.32	13.47	13.44	13.44	13.58	13.72	13.87	13.87	14.07	14.21	14.96	14.96	14.96	14.96	
		S/T	0.87	0.91	1.00	1.00	0.76	0.80	0.94	1.00	0.66	0.70	0.83	0.96	0.42	0.45	0.58	0.71	
		PI	3.98	3.98	3.98	3.98	3.99	3.99	3.99	3.99	3.99	3.99	4.00	3.99	4.02	4.02	4.02	4.02	
	43.0	TC	12.34	12.47	12.60	12.73	12.74	12.74	12.87	13.00	13.15	13.15	13.29	13.42	14.22	14.22	14.22	14.22	
		S/T	0.91	0.96	1.00	1.00	0.79	0.84	0.99	1.00	0.68	0.72	0.88	1.00	0.42	0.46	0.60	0.90	
		PI	4.77	4.77	4.77	4.77	4.78	4.78	4.78	4.78	4.80	4.80	4.80	4.80	4.83	4.83	4.83	4.83	
	46.0	TC	12.12	12.24	12.36	12.49	12.52	12.52	12.64	12.76	12.91	12.91	13.04	13.16	13.99	13.99	13.99	13.99	
		S/T	0.93	0.98	1.00	1.00	0.81	0.86	1.00	1.00	0.69	0.74	0.89	1.00	0.42	0.46	0.61	0.92	
		PI	5.07	5.07	5.07	5.07	5.08	5.08	5.08	5.08	5.10	5.10	5.10	5.10	5.14	5.14	5.14	5.14	
	52.0	TC	10.23	10.34	10.46	10.57	10.57	10.68	10.80	10.91	10.94	10.94	11.05	11.17	11.88	11.88	11.88	11.88	
		S/T	0.98	1.00	1.00	1.00	0.85	0.90	1.00	1.00	0.72	0.77	0.94	1.00	0.42	0.47	0.63	0.97	
		PI	5.51	5.51	5.51	5.51	5.52	5.52	5.52	5.52	5.54	5.54	5.54	5.54	5.58	5.58	5.58	5.58	

TC: Total Capacity(kW)

S/T: Sensible Capacity ratio

PI: Power Input(kW)

Note: Above deration table showing the data was simulated basing on a fixed compressor speed.

42QSM060VT+38QST060VT																			
INDOOR AIRFLOW (L/S)	OUTDOOR DB (°C)	ID WB (°C)	17.2			18.0				19.0				22.0					
			24.4	25.0	27.0	29.0	24.4	25.0	27.0	29.0	24.4	25.0	27.0	29.0	24.4	25.0	27.0	29.0	
686	27.0	TC	15.33	15.33	15.48	15.62	15.82	15.82	15.99	16.28	16.28	16.28	16.28	17.55	17.55	17.55	17.55		
		S/T	0.77	0.80	0.90	1.00	0.68	0.71	0.82	0.92	0.60	0.63	0.73	0.83	0.41	0.44	0.53	0.63	
		PI	3.73	3.73	3.73	3.73	3.73	3.73	3.73	3.73	3.74	3.74	3.74	3.74	3.74	3.74	3.74	3.74	
	30.0	TC	14.90	14.90	15.05	15.19	15.36	15.36	15.51	15.85	15.85	15.85	15.85	17.06	17.06	17.06	17.06		
		S/T	0.77	0.81	0.91	1.00	0.69	0.72	0.83	0.93	0.60	0.63	0.74	0.84	0.41	0.44	0.54	0.63	
		PI	3.95	3.95	3.95	3.95	3.95	3.95	3.95	3.95	3.96	3.96	3.96	3.96	3.97	3.97	3.97	3.97	
	32.0	TC	14.62	14.62	14.76	14.90	15.08	15.08	15.22	15.54	15.54	15.54	15.54	16.74	16.74	16.74	16.74		
		S/T	0.78	0.81	0.92	1.00	0.69	0.72	0.83	0.94	0.61	0.64	0.74	0.85	0.41	0.44	0.54	0.64	
		PI	4.09	4.09	4.09	4.09	4.10	4.10	4.10	4.10	4.11	4.11	4.11	4.11	4.13	4.13	4.13	4.13	
	35.0	TC	14.16	14.16	14.30	14.44	14.62	14.62	14.76	15.08	15.08	15.31	15.08	16.25	16.25	16.25	16.25		
		S/T	0.79	0.82	0.94	1.00	0.70	0.73	0.84	0.95	0.61	0.64	0.75	0.86	0.41	0.44	0.54	0.65	
		PI	4.32	4.32	4.32	4.32	4.32	4.32	4.32	4.32	4.33	4.33	4.34	4.33	4.36	4.36	4.36	4.36	
	43.0	TC	13.28	13.28	13.40	13.53	13.71	13.71	13.80	13.92	14.16	14.16	14.22	14.27	15.29	15.29	15.29	15.29	
		S/T	0.82	0.86	0.98	1.00	0.72	0.76	0.88	1.00	0.63	0.66	0.78	0.90	0.41	0.45	0.56	0.67	
		PI	5.04	5.04	5.04	5.04	5.05	5.05	5.05	5.05	5.07	5.07	5.07	5.07	5.10	5.10	5.10	5.10	
	46.0	TC	12.94	12.94	13.06	13.18	13.36	13.36	13.48	13.60	13.81	13.81	13.81	13.96	14.92	14.92	14.92	14.92	
		S/T	0.84	0.88	1.00	1.00	0.73	0.77	0.90	1.00	0.64	0.67	0.80	0.92	0.41	0.45	0.56	0.68	
		PI	5.31	5.31	5.31	5.31	5.32	5.32	5.32	5.32	5.34	5.34	5.34	5.34	5.38	5.38	5.38	5.38	
	52.0	TC	11.24	11.36	11.47	11.59	11.62	11.62	11.73	11.85	12.02	12.02	12.02	12.13	13.02	13.02	13.02	13.02	
		S/T	0.87	0.91	1.00	1.00	0.76	0.80	0.94	1.00	0.66	0.70	0.84	0.97	0.42	0.45	0.58	0.71	
		PI	5.98	5.98	5.98	5.98	6.00	6.00	6.00	6.00	6.01	6.01	6.01	6.01	6.06	6.06	6.06	6.06	
	819	27.0	TC	15.66	15.66	15.80	15.97	16.14	16.14	16.14	16.32	16.63	16.63	16.63	16.81	17.90	17.90	17.90	17.90
			S/T	0.81	0.85	0.97	1.00	0.72	0.75	0.88	0.99	0.62	0.66	0.78	0.89	0.41	0.45	0.56	0.67
			PI	3.81	3.81	3.81	3.81	3.81	3.81	3.81	3.81	3.81	3.81	3.81	3.81	3.82	3.82	3.82	3.82
30.0		TC	15.23	15.23	15.37	15.51	15.69	15.69	15.83	16.00	16.17	16.17	16.17	16.35	17.44	17.44	17.44	17.44	
		S/T	0.82	0.86	0.99	1.00	0.73	0.76	0.89	1.00	0.63	0.67	0.79	0.91	0.41	0.45	0.56	0.67	
		PI	4.03	4.03	4.03	4.03	4.03	4.03	4.03	4.03	4.04	4.04	4.04	4.04	4.06	4.06	4.06	4.06	
32.0		TC	14.94	14.94	15.08	15.23	15.40	15.40	15.54	15.69	15.86	15.86	15.86	16.03	17.09	17.09	17.09	17.09	
		S/T	0.83	0.87	1.00	1.00	0.73	0.77	0.89	1.00	0.63	0.67	0.80	0.92	0.41	0.45	0.56	0.68	
		PI	4.18	4.18	4.18	4.18	4.19	4.19	4.19	4.19	4.19	4.19	4.19	4.19	4.21	4.21	4.21	4.21	
35.0		TC	14.48	14.48	14.62	14.77	14.94	14.94	15.08	15.23	15.40	15.40	15.63	15.77	16.60	16.60	16.60	16.60	
		S/T	0.84	0.88	1.00	1.00	0.74	0.78	0.91	1.00	0.64	0.68	0.80	0.92	0.41	0.45	0.57	0.69	
		PI	4.41	4.41	4.41	4.41	4.41	4.41	4.41	4.41	4.42	4.42	4.43	4.42	4.42	4.42	4.42	4.42	
43.0		TC	13.40	13.49	13.61	13.74	13.82	13.82	13.97	14.12	14.27	14.27	14.33	14.48	15.44	15.44	15.44	15.44	
		S/T	0.88	0.92	1.00	1.00	0.77	0.81	0.95	1.00	0.66	0.70	0.84	0.98	0.42	0.46	0.59	0.72	
		PI	5.15	5.15	5.15	5.15	5.15	5.15	5.15	5.15	5.17	5.17	5.17	5.17	5.20	5.20	5.20	5.20	
46.0		TC	13.05	13.17	13.29	13.41	13.47	13.47	13.62	13.77	13.91	13.91	13.91	14.06	15.07	15.07	15.07	15.07	
		S/T	0.90	0.94	1.00	1.00	0.78	0.83	0.97	1.00	0.67	0.72	0.86	1.00	0.42	0.46	0.59	0.73	
		PI	5.42	5.42	5.42	5.42	5.43	5.43	5.43	5.43	5.45	5.45	5.45	5.45	5.49	5.49	5.49	5.49	
52.0		TC	11.34	11.45	11.56	11.68	11.70	11.70	11.82	11.93	12.10	12.10	12.22	12.33	13.15	13.15	13.15	13.15	
		S/T	0.95	0.99	1.00	1.00	0.82	0.87	1.00	1.00	0.70	0.75	0.90	1.00	0.42	0.47	0.62	0.91	
		PI	6.11	6.11	6.11	6.11	6.12	6.12	6.12	6.12	6.14	6.14	6.14	6.14	6.18	6.18	6.18	6.18	
936		27.0	TC	16.00	16.17	16.35	16.52	16.49	16.49	16.66	16.83	16.98	16.98	16.98	17.15	18.27	18.27	18.27	18.27
			S/T	0.86	0.89	1.00	1.00	0.75	0.79	0.92	1.00	0.65	0.69	0.82	0.95	0.41	0.45	0.58	0.70
			PI	3.89	3.89	3.89	3.89	3.89	3.89	3.89	3.89	3.89	3.89	3.89	3.89	3.90	3.90	3.90	3.90
	30.0	TC	15.54	15.69	15.83	16.00	16.00	16.00	16.17	16.35	16.49	16.49	16.49	16.66	17.78	17.78	17.78	17.78	
		S/T	0.87	0.91	1.00	1.00	0.76	0.80	0.94	1.00	0.65	0.70	0.83	0.96	0.42	0.45	0.58	0.71	
		PI	4.11	4.11	4.11	4.11	4.11	4.11	4.11	4.11	4.12	4.12	4.12	4.12	4.14	4.14	4.14	4.14	
	32.0	TC	15.23	15.37	15.51	15.66	15.71	15.71	15.86	16.03	16.17	16.17	16.17	16.35	17.44	17.44	17.44	17.44	
		S/T	0.88	0.92	1.00	1.00	0.76	0.81	0.95	1.00	0.66	0.70	0.84	0.98	0.42	0.46	0.58	0.71	
		PI	4.26	4.26	4.26	4.26	4.27	4.27	4.27	4.27	4.27	4.27	4.27	4.27	4.29	4.29	4.29	4.29	
	35.0	TC	14.77	14.91	15.05	15.20	15.23	15.23	15.37	15.51	15.71	15.71	15.94	16.12	16.95	16.95	16.95	16.95	
		S/T	0.89	0.93	1.00	1.00	0.78	0.82	0.96	1.00	0.67	0.71	0.85	0.98	0.42	0.46	0.59	0.72	
		PI	4.50	4.50	4.50	4.50	4.50	4.50	4.50	4.50	4.51	4.51	4.52	4.51	4.54	4.54	4.54	4.54	
	43.0	TC	13.67	13.80	13.94	14.09	14.10	14.10	14.24	14.39	14.57	14.57	14.74	14.90	15.75	15.75	15.75	15.75	
		S/T	0.93	0.98	1.00	1.00	0.81	0.86	1.00	1.00	0.69	0.74	0.89	1.00	0.42	0.46	0.61	0.90	
		PI	5.25	5.25	5.25	5.25	5.26	5.26	5.26	5.26	5.27	5.27	5.28	5.27	5.31	5.31	5.31	5.31	
	46.0	TC	13.32	13.44	13.59	13.74	13.74	13.74	13.88	14.03	14.21	14.21	14.36	14.51	15.37	15.37	15.37	15.37	
		S/T	0.95	1.00	1.00	1.00	0.83	0.88	1.00	1.00	0.70	0.75	0.91	1.00	0.42	0.47	0.62	0.92	
		PI	5.53	5.53	5.53	5.53	5.54	5.54	5.54	5.54	5.56	5.56	5.56	5.56	5.60	5.60	5.60	5.60	
	52.0	TC	11.56	11.68	11.79	11.90	11.96	11.96	12.07	12.19	12.30	12.36	12.36	12.47	13.41	13.41	13.41	13.41	
		S/T	1.00	1.00	1.00	1.00	0.86	0.92	1.00	1.00	0.73	0.79	0.96	1.00	0.43	0.48	0.64	0.97	
		PI	6.23	6.23	6.23	6.23	6.25	6.25	6.25	6.25	6.26	6.26	6.26	6.26	6.31	6.31	6.31	6.31	

TC: Total Capacity(kW)

S/T: Sensible Capacity ratio

PI: Power Input(kW)

Note: Above deration table showing the data was simulated basing on a fixed compressor speed.

6.2 Heating

		18k [SI_Unit]							
INDOOR AIRFLOW W (L/S)	HEATING PERFORMANCE AT INDOOR DRY BULB TEMPERATURE								
	OUTDOOR DB (°C)	TC : TOTAL CAPACITY IN KILOWATTS				PI : TOTAL POWER IN KILOWATTS			
		Indoor Conditions (DB °C)				Indoor Conditions (DB °C)			
		16.0	20.0	22.0	24.0	16.0	20.0	22.0	24.0
175	-15.0	3.38	3.35	3.33	3.30	0.94	0.97	1.01	1.04
	-10.0	3.61	3.58	3.55	3.53	1.00	1.03	1.08	1.10
	-7.0	3.78	3.75	3.72	3.70	1.07	1.10	1.14	1.17
	-5.6	4.01	3.98	3.95	3.93	1.10	1.15	1.18	1.20
	-2.8	4.25	4.19	4.16	4.13	1.17	1.22	1.25	1.28
	0.0	4.39	4.33	4.30	4.27	1.24	1.30	1.33	1.36
	2.8	4.74	4.68	4.62	4.59	1.32	1.39	1.42	1.45
	5.6	5.23	5.18	5.12	5.09	1.41	1.48	1.51	1.55
	7.0	5.75	5.69	5.51	5.48	1.46	1.59	1.57	1.60
	11.1	6.12	6.03	6.01	5.95	1.58	1.65	1.69	1.73
	13.9	6.44	6.35	6.32	6.27	1.65	1.73	1.77	1.81
	16.7	6.79	6.67	6.64	6.59	1.73	1.82	1.86	1.90
18.0	6.93	6.85	6.79	6.76	1.77	1.86	1.90	1.94	
224	-15.0	3.48	3.43	3.41	3.38	0.96	0.98	1.03	1.04
	-10.0	3.72	3.66	3.64	3.61	1.02	1.04	1.10	1.11
	-7.0	3.89	3.84	3.81	3.78	1.09	1.11	1.16	1.18
	-5.6	4.13	4.07	4.04	4.01	1.11	1.17	1.19	1.22
	-2.8	4.33	4.27	4.25	4.22	1.18	1.24	1.27	1.30
	0.0	4.51	4.45	4.39	4.36	1.25	1.32	1.35	1.38
	2.8	4.83	4.77	4.74	4.71	1.34	1.41	1.44	1.47
	5.6	5.35	5.26	5.23	5.21	1.43	1.50	1.53	1.57
	7.0	5.90	5.80	5.63	5.60	1.48	1.61	1.59	1.62
	11.1	6.24	6.15	6.12	6.06	1.60	1.67	1.71	1.75
	13.9	6.56	6.47	6.44	6.38	1.68	1.76	1.80	1.84
	16.7	6.90	6.82	6.76	6.73	1.75	1.84	1.88	1.92
18.0	7.08	6.96	6.93	6.88	1.79	1.88	1.92	1.97	
269	-15.0	3.51	3.46	3.43	3.41	0.97	0.99	1.04	1.06
	-10.0	3.74	3.69	3.67	3.64	1.03	1.06	1.10	1.13
	-7.0	3.92	3.87	3.84	3.81	1.10	1.12	1.17	1.20
	-5.6	4.16	4.10	4.07	4.04	1.13	1.18	1.21	1.24
	-2.8	4.36	4.30	4.27	4.27	1.20	1.26	1.29	1.32
	0.0	4.54	4.48	4.45	4.42	1.27	1.33	1.36	1.40
	2.8	4.89	4.80	4.77	4.74	1.36	1.42	1.46	1.49
	5.6	5.41	5.32	5.29	5.26	1.45	1.52	1.55	1.59
	7.0	5.96	5.86	5.69	5.66	1.50	1.63	1.61	1.64
	11.1	6.30	6.21	6.18	6.12	1.62	1.69	1.73	1.77
	13.9	6.64	6.56	6.50	6.47	1.70	1.78	1.82	1.86
	16.7	6.99	6.88	6.85	6.79	1.78	1.86	1.90	1.95
18.0	7.14	7.05	6.99	6.96	1.81	1.90	1.95	1.99	

Note: Above deration table showing the data was simulated basing on a fixed compressor speed.

24k [SI_Unit]									
INDOOR AIRFLOW W (L/S)	HEATING PERFORMANCE AT INDOOR DRY BULB TEMPERATURE								
	OUTDOOR DB (°C)	TC : TOTAL CAPACITY IN KILOWATTS				PI : TOTAL POWER IN KILOWATTS			
		Indoor Conditions (DB °C)				Indoor Conditions (DB °C)			
		16.0	20.0	22.0	24.0	16.0	20.0	22.0	24.0
244	-15.0	4.73	4.68	4.63	4.61	1.34	1.37	1.44	1.47
	-10.0	5.05	5.00	4.95	4.92	1.43	1.47	1.53	1.57
	-7.0	5.29	5.24	5.18	5.16	1.52	1.56	1.63	1.67
	-5.6	5.61	5.56	5.50	5.47	1.57	1.65	1.68	1.72
	-2.8	5.90	5.85	5.79	5.76	1.67	1.75	1.79	1.83
	0.0	6.14	6.05	6.02	5.96	1.77	1.85	1.89	1.93
	2.8	6.60	6.51	6.45	6.42	1.88	1.97	2.02	2.07
	5.6	7.29	7.18	7.15	7.09	2.01	2.10	2.15	2.20
	7.0	8.07	7.94	7.71	7.65	2.07	2.26	2.23	2.28
	11.1	8.52	8.43	8.37	8.32	2.24	2.35	2.40	2.46
	13.9	8.98	8.87	8.81	8.75	2.35	2.47	2.52	2.58
	16.7	9.45	9.33	9.27	9.19	2.46	2.58	2.64	2.70
18.0	9.68	9.53	9.47	9.42	2.52	2.64	2.70	2.76	
306	-15.0	4.83	4.78	4.73	4.70	1.36	1.39	1.45	1.49
	-10.0	5.15	5.10	5.05	5.02	1.45	1.48	1.55	1.59
	-7.0	5.40	5.34	5.29	5.26	1.54	1.57	1.65	1.69
	-5.6	5.73	5.67	5.61	5.59	1.59	1.66	1.70	1.74
	-2.8	6.05	5.96	5.93	5.88	1.69	1.77	1.81	1.84
	0.0	6.25	6.16	6.14	6.11	1.79	1.86	1.91	1.95
	2.8	6.74	6.63	6.60	6.54	1.90	1.99	2.04	2.09
	5.6	7.44	7.35	7.29	7.24	2.02	2.12	2.17	2.22
	7.0	8.20	8.11	7.85	7.82	2.09	2.28	2.25	2.30
	11.1	8.72	8.61	8.55	8.49	2.26	2.37	2.42	2.48
	13.9	9.19	9.07	9.01	8.92	2.37	2.49	2.54	2.60
	16.7	9.65	9.53	9.45	9.39	2.48	2.60	2.66	2.72
18.0	9.88	9.74	9.68	9.62	2.54	2.66	2.72	2.78	
379	-15.0	4.89	4.84	4.81	4.79	1.37	1.40	1.46	1.50
	-10.0	5.22	5.17	5.14	5.11	1.46	1.49	1.56	1.60
	-7.0	5.47	5.41	5.38	5.36	1.55	1.59	1.66	1.70
	-5.6	5.79	5.73	5.70	5.67	1.60	1.68	1.72	1.75
	-2.8	6.11	6.02	5.99	5.96	1.70	1.78	1.83	1.86
	0.0	6.34	6.25	6.22	6.16	1.80	1.88	1.92	1.97
	2.8	6.80	6.71	6.66	6.63	1.92	2.01	2.06	2.10
	5.6	7.52	7.44	7.38	7.32	2.04	2.14	2.19	2.24
	7.0	8.30	8.20	7.97	7.91	2.11	2.30	2.27	2.32
	11.1	8.81	8.69	8.63	8.58	2.28	2.39	2.44	2.50
	13.9	9.27	9.16	9.10	9.04	2.39	2.51	2.57	2.62
	16.7	9.76	9.62	9.56	9.50	2.51	2.63	2.69	2.75
18.0	10.00	9.85	9.79	9.71	2.56	2.68	2.74	2.81	

Note: Above deration table showing the data was simulated basing on a fixed compressor speed.

30k [SI_Unit]									
INDOOR AIRFLOW W (L/S)	HEATING PERFORMANCE AT INDOOR DRY BULB TEMPERATURE								
	OUTDOOR DB (°C)	TC : TOTAL CAPACITY IN KILOWATTS				PI : TOTAL POWER IN KILOWATTS			
		Indoor Conditions (DB °C)				Indoor Conditions (DB °C)			
		16.0	20.0	22.0	24.0	16.0	20.0	22.0	24.0
275	-15.0	5.45	5.38	5.35	5.33	1.53	1.56	1.63	1.66
	-10.0	5.82	5.74	5.72	5.69	1.63	1.66	1.74	1.78
	-7.0	6.10	6.02	5.99	5.96	1.73	1.77	1.85	1.89
	-5.6	6.45	6.37	6.34	6.31	1.78	1.87	1.91	1.95
	-2.8	6.80	6.71	6.66	6.63	1.89	1.98	2.03	2.07
	0.0	7.06	6.95	6.92	6.86	2.00	2.09	2.14	2.19
	2.8	7.59	7.47	7.44	7.38	2.13	2.24	2.29	2.34
	5.6	8.40	8.28	8.23	8.17	2.27	2.38	2.44	2.49
	7.0	9.25	9.12	8.86	8.80	2.35	2.56	2.52	2.58
	11.1	9.82	9.67	9.61	9.55	2.54	2.66	2.72	2.78
	13.9	10.34	10.19	10.14	10.05	2.66	2.79	2.86	2.92
	16.7	10.86	10.72	10.63	10.57	2.79	2.92	2.99	3.06
18.0	11.12	10.95	10.89	10.80	2.85	2.99	3.05	3.11	
336	-15.0	5.56	5.49	5.44	5.41	1.53	1.58	1.65	1.68
	-10.0	5.94	5.86	5.81	5.78	1.64	1.68	1.76	1.79
	-7.0	6.22	6.14	6.08	6.06	1.74	1.79	1.87	1.91
	-5.6	6.60	6.51	6.45	6.42	1.80	1.89	1.93	1.97
	-2.8	6.95	6.86	6.80	6.74	1.91	2.01	2.04	2.09
	0.0	7.21	7.09	7.03	7.00	2.03	2.12	2.17	2.22
	2.8	7.73	7.61	7.59	7.53	2.16	2.26	2.32	2.37
	5.6	8.55	8.43	8.37	8.31	2.30	2.41	2.47	2.52
	7.0	9.42	9.29	9.00	8.94	2.38	2.59	2.55	2.61
	11.1	9.99	9.84	9.79	9.73	2.57	2.69	2.75	2.81
	13.9	10.51	10.40	10.31	10.25	2.69	2.82	2.89	2.95
	16.7	11.06	10.92	10.83	10.77	2.82	2.96	3.03	3.08
18.0	11.33	11.18	11.09	11.01	2.88	3.02	3.08	3.15	
394	-15.0	5.58	5.53	5.49	5.46	1.56	1.60	1.66	1.71
	-10.0	5.96	5.91	5.86	5.83	1.66	1.70	1.78	1.82
	-7.0	6.25	6.19	6.14	6.11	1.77	1.81	1.89	1.94
	-5.6	6.63	6.57	6.51	6.48	1.82	1.91	1.95	2.00
	-2.8	7.00	6.92	6.86	6.83	1.93	2.03	2.07	2.12
	0.0	7.27	7.15	7.12	7.06	2.04	2.14	2.19	2.24
	2.8	7.79	7.70	7.64	7.59	2.18	2.29	2.34	2.40
	5.6	8.63	8.52	8.46	8.40	2.33	2.44	2.50	2.55
	7.0	9.51	9.38	9.09	9.03	2.41	2.62	2.58	2.64
	11.1	10.08	9.96	9.87	9.82	2.60	2.72	2.78	2.85
	13.9	10.63	10.48	10.43	10.34	2.73	2.86	2.92	2.99
	16.7	11.18	11.01	10.95	10.86	2.85	2.99	3.06	3.12
18.0	11.44	11.27	11.21	11.12	2.92	3.06	3.12	3.19	

Note: Above deration table showing the data was simulated basing on a fixed compressor speed.

36k [SI_Unit]									
INDOOR AIRFLOW W (L/S)	HEATING PERFORMANCE AT INDOOR DRY BULB TEMPERATURE								
	OUTDOOR DB (°C)	TC : TOTAL CAPACITY IN KILOWATTS				PI : TOTAL POWER IN KILOWATTS			
		Indoor Conditions (DB °C)				Indoor Conditions (DB °C)			
		16.0	20.0	22.0	24.0	16.0	20.0	22.0	24.0
378	-15.0	6.95	6.87	6.82	6.77	1.81	1.85	1.94	1.98
	-10.0	7.42	7.34	7.29	7.23	1.93	1.98	2.07	2.12
	-7.0	7.77	7.69	7.63	7.58	2.05	2.10	2.20	2.25
	-5.6	8.24	8.15	8.09	8.04	2.11	2.21	2.27	2.32
	-2.8	8.67	8.56	8.50	8.47	2.24	2.36	2.41	2.47
	0.0	8.99	8.88	8.82	8.76	2.38	2.50	2.55	2.60
	2.8	9.66	9.54	9.49	9.40	2.54	2.66	2.72	2.78
	5.6	10.71	10.56	10.47	10.41	2.70	2.83	2.90	2.96
	7.0	11.78	11.62	11.28	11.19	2.79	3.04	2.99	3.06
	11.1	12.49	12.32	12.23	12.17	3.01	3.16	3.23	3.30
	13.9	13.16	12.99	12.90	12.81	3.16	3.31	3.39	3.47
	16.7	13.83	13.65	13.57	13.45	3.31	3.47	3.55	3.62
18.0	14.14	13.97	13.86	13.77	3.38	3.55	3.62	3.70	
522	-15.0	7.11	7.01	6.96	6.93	1.83	1.87	1.96	2.00
	-10.0	7.59	7.48	7.43	7.40	1.95	1.99	2.09	2.13
	-7.0	7.95	7.84	7.78	7.76	2.07	2.12	2.22	2.27
	-5.6	8.41	8.30	8.24	8.21	2.13	2.23	2.29	2.34
	-2.8	8.85	8.73	8.67	8.62	2.27	2.38	2.43	2.49
	0.0	9.20	9.05	8.99	8.94	2.40	2.52	2.57	2.63
	2.8	9.86	9.75	9.66	9.60	2.56	2.68	2.75	2.81
	5.6	10.91	10.76	10.71	10.62	2.72	2.86	2.92	2.99
	7.0	12.03	11.87	11.51	11.45	2.82	3.07	3.02	3.09
	11.1	12.75	12.58	12.49	12.41	3.04	3.19	3.26	3.34
	13.9	13.45	13.28	13.16	13.07	3.19	3.35	3.42	3.50
	16.7	14.12	13.94	13.86	13.74	3.34	3.51	3.59	3.66
18.0	14.46	14.26	14.17	14.06	3.42	3.58	3.65	3.74	
625	-15.0	7.18	7.08	7.03	7.01	1.84	1.89	1.97	2.02
	-10.0	7.66	7.56	7.51	7.48	1.97	2.01	2.11	2.15
	-7.0	8.03	7.92	7.87	7.84	2.09	2.14	2.24	2.29
	-5.6	8.50	8.38	8.33	8.30	2.15	2.26	2.31	2.36
	-2.8	8.94	8.85	8.79	8.73	2.29	2.40	2.46	2.51
	0.0	9.28	9.17	9.11	9.02	2.42	2.54	2.59	2.65
	2.8	9.98	9.83	9.78	9.72	2.58	2.71	2.77	2.84
	5.6	11.02	10.88	10.82	10.73	2.75	2.89	2.95	3.02
	7.0	12.16	12.00	11.65	11.57	2.85	3.10	3.05	3.12
	11.1	12.90	12.72	12.64	12.55	3.07	3.22	3.29	3.37
	13.9	13.59	13.42	13.33	13.22	3.22	3.38	3.46	3.54
	16.7	14.29	14.09	14.00	13.91	3.38	3.54	3.62	3.69
18.0	14.61	14.43	14.32	14.23	3.45	3.62	3.69	3.77	

Note: Above deration table showing the data was simulated basing on a fixed compressor speed.

48k [SI_Unit]									
INDOOR AIRFLOW (L/S)	HEATING PERFORMANCE AT INDOOR DRY BULB TEMPERATURE								
	OUTDOOR DB (°C)	TC : TOTAL CAPACITY IN KILOWATTS				PI : TOTAL POWER IN KILOWATTS			
		Indoor Conditions (DB °C)				Indoor Conditions (DB °C)			
		16.0	20.0	22.0	24.0	16.0	20.0	22.0	24.0
550	-15.0	9.04	8.92	8.87	8.82	2.34	2.40	2.51	2.56
	-10.0	9.65	9.52	9.47	9.42	2.49	2.56	2.68	2.73
	-7.0	10.11	9.98	9.92	9.87	2.65	2.72	2.85	2.91
	-5.6	10.70	10.56	10.50	10.44	2.73	2.87	2.93	2.99
	-2.8	11.28	11.14	11.05	10.99	2.91	3.04	3.11	3.18
	0.0	11.69	11.54	11.46	11.40	3.07	3.22	3.30	3.38
	2.8	12.59	12.41	12.33	12.24	3.28	3.45	3.53	3.61
	5.6	13.92	13.72	13.63	13.54	3.50	3.67	3.75	3.84
	7.0	15.36	15.14	14.67	14.59	3.61	3.93	3.87	3.96
	11.1	16.27	16.06	15.95	15.83	3.89	4.08	4.18	4.27
	13.9	17.14	16.93	16.82	16.70	4.09	4.29	4.38	4.48
	16.7	18.04	17.77	17.66	17.54	4.28	4.49	4.58	4.68
18.0	18.44	18.21	18.06	17.95	4.37	4.57	4.68	4.79	
675	-15.0	9.23	9.11	9.06	8.99	2.36	2.42	2.54	2.59
	-10.0	9.86	9.73	9.67	9.59	2.52	2.58	2.71	2.76
	-7.0	10.33	10.19	10.13	10.05	2.68	2.74	2.88	2.94
	-5.6	10.93	10.79	10.73	10.64	2.76	2.90	2.96	3.02
	-2.8	11.51	11.37	11.28	11.22	2.94	3.07	3.14	3.22
	0.0	11.95	11.78	11.69	11.60	3.10	3.26	3.33	3.41
	2.8	12.82	12.65	12.56	12.47	3.32	3.48	3.56	3.64
	5.6	14.18	14.01	13.89	13.81	3.53	3.71	3.79	3.88
	7.0	15.63	15.43	14.96	14.88	3.65	3.97	3.91	4.00
	11.1	16.59	16.38	16.27	16.15	3.93	4.12	4.22	4.31
	13.9	17.48	17.25	17.14	17.02	4.13	4.33	4.43	4.52
	16.7	18.38	18.12	18.01	17.89	4.33	4.52	4.63	4.73
18.0	18.79	18.56	18.41	18.30	4.42	4.62	4.73	4.83	
792	-15.0	9.33	9.20	9.16	9.08	2.38	2.44	2.56	2.62
	-10.0	9.96	9.83	9.78	9.70	2.54	2.60	2.73	2.79
	-7.0	10.43	10.30	10.24	10.16	2.70	2.77	2.90	2.97
	-5.6	11.05	10.91	10.85	10.76	2.78	2.92	2.99	3.05
	-2.8	11.63	11.49	11.40	11.34	2.96	3.10	3.17	3.24
	0.0	12.07	11.89	11.83	11.75	3.13	3.29	3.36	3.44
	2.8	12.96	12.79	12.70	12.62	3.35	3.51	3.60	3.68
	5.6	14.33	14.15	14.07	13.95	3.57	3.74	3.83	3.92
	7.0	15.79	15.60	15.14	15.02	3.68	4.01	3.95	4.04
	11.1	16.76	16.56	16.44	16.32	3.97	4.17	4.26	4.36
	13.9	17.66	17.43	17.31	17.19	4.17	4.37	4.47	4.57
	16.7	18.56	18.33	18.21	18.06	4.37	4.57	4.68	4.78
18.0	18.99	18.76	18.62	18.50	4.47	4.67	4.78	4.89	

Note: Above deration table showing the data was simulated basing on a fixed compressor speed.

60k [SI_Unit]									
INDOOR AIRFLOW W (L/S)	HEATING PERFORMANCE AT INDOOR DRY BULB TEMPERATURE								
	OUTDOOR DB (°C)	TC : TOTAL CAPACITY IN KILOWATTS				PI : TOTAL POWER IN KILOWATTS			
		Indoor Conditions (DB °C)				Indoor Conditions (DB °C)			
		16.0	20.0	22.0	24.0	16.0	20.0	22.0	24.0
686	-15.0	9.61	9.48	9.41	9.36	2.60	2.66	2.79	2.85
	-10.0	10.26	10.13	10.05	10.00	2.78	2.84	2.97	3.04
	-7.0	10.74	10.61	10.53	10.47	2.95	3.02	3.16	3.23
	-5.6	11.39	11.25	11.16	11.10	3.04	3.18	3.26	3.32
	-2.8	12.00	11.83	11.77	11.68	3.23	3.38	3.46	3.54
	0.0	12.43	12.26	12.17	12.09	3.41	3.58	3.67	3.75
	2.8	13.36	13.19	13.10	13.01	3.65	3.83	3.92	4.01
	5.6	14.78	14.58	14.49	14.38	3.89	4.08	4.17	4.26
	7.0	16.33	16.11	15.61	15.53	4.02	4.38	4.31	4.41
	11.1	17.33	17.09	16.98	16.86	4.34	4.55	4.65	4.76
	13.9	18.25	17.99	17.88	17.76	4.56	4.78	4.89	5.00
	16.7	19.18	18.92	18.81	18.66	4.77	5.00	5.11	5.22
18.0	19.62	19.36	19.24	19.10	4.88	5.10	5.22	5.33	
819	-15.0	9.81	9.69	9.61	9.56	2.62	2.69	2.81	2.87
	-10.0	10.47	10.34	10.26	10.21	2.79	2.87	3.00	3.06
	-7.0	10.97	10.83	10.75	10.70	2.97	3.05	3.19	3.26
	-5.6	11.62	11.48	11.39	11.33	3.06	3.21	3.29	3.35
	-2.8	12.23	12.09	12.00	11.91	3.26	3.41	3.49	3.57
	0.0	12.70	12.52	12.43	12.35	3.44	3.61	3.70	3.79
	2.8	13.65	13.45	13.36	13.27	3.68	3.86	3.95	4.05
	5.6	15.10	14.90	14.78	14.69	3.92	4.11	4.21	4.30
	7.0	16.66	16.44	15.93	15.85	4.06	4.42	4.35	4.45
	11.1	17.67	17.44	17.33	17.21	4.38	4.59	4.70	4.80
	13.9	18.60	18.37	18.25	18.11	4.60	4.82	4.93	5.03
	16.7	19.56	19.30	19.18	19.04	4.82	5.04	5.15	5.27
18.0	20.02	19.76	19.62	19.47	4.92	5.15	5.26	5.38	
936	-15.0	9.92	9.79	9.75	9.67	2.65	2.72	2.84	2.91
	-10.0	10.59	10.46	10.41	10.33	2.82	2.90	3.03	3.10
	-7.0	11.09	10.96	10.90	10.82	3.00	3.08	3.22	3.30
	-5.6	11.74	11.59	11.54	11.45	3.10	3.25	3.31	3.39
	-2.8	12.38	12.20	12.14	12.06	3.29	3.44	3.52	3.61
	0.0	12.84	12.67	12.58	12.49	3.48	3.65	3.74	3.82
	2.8	13.80	13.59	13.51	13.42	3.72	3.90	3.99	4.08
	5.6	15.25	15.04	14.93	14.84	3.96	4.15	4.25	4.33
	7.0	16.82	16.60	16.11	15.99	4.10	4.46	4.39	4.49
	11.1	17.85	17.62	17.50	17.35	4.42	4.63	4.74	4.85
	13.9	18.81	18.54	18.43	18.28	4.64	4.86	4.97	5.07
	16.7	19.76	19.50	19.36	19.21	4.86	5.08	5.20	5.31
18.0	20.23	19.94	19.79	19.68	4.96	5.19	5.31	5.43	

7. Capacity Correction Factor for Height Difference

Model	18K		Pipe Length (m)					
Cooling			5	10	15	25		
Height difference H (m)	Indoor Upper than Outdoor							
		15			0.937	0.918		
		10		0.971	0.947	0.927		
		5	0.995	0.980	0.956	0.937		
		0	1.000	0.985	0.961	0.941		
	Outdoor Upper than Indoor	-5	1.000	0.985	0.961	0.941		
		-10		0.985	0.961	0.941		
		-15			0.961	0.941		
Heating			5	10	15	25		
Height difference H (m)	Indoor Upper than Outdoor							
		15			0.991	0.986		
		10		0.996	0.991	0.986		
		5	1.000	0.996	0.991	0.986		
		0	1.000	0.996	0.991	0.986		
	Outdoor Upper than Indoor	-5	0.992	0.989	0.983	0.978		
		-10		0.981	0.975	0.970		
		-15			0.967	0.962		

Model	24K		Pipe Length (m)					
Cooling			5	10	15	25		
Height difference H (m)	Indoor Upper than Outdoor							
		15			0.943	0.910		
		10		0.969	0.952	0.919		
		5	0.995	0.978	0.962	0.929		
		0	1.000	0.983	0.967	0.933		
	Outdoor Upper than Indoor	-5	1.000	0.983	0.967	0.933		
		-10		0.983	0.967	0.933		
		-15				0.933		
Heating			5	10	15	25		
Height difference H (m)	Indoor Upper than Outdoor							
		15			0.990	0.981		
		10		0.995	0.990	0.981		
		5	1.000	0.995	0.990	0.981		
		0	1.000	0.995	0.990	0.981		
	Outdoor Upper than Indoor	-5	0.992	0.987	0.983	0.973		
		-10		0.979	0.975	0.965		
		-15			0.967	0.958		

Model	30K		Pipe Length (m)					
Cooling			5	10	15	20	25	30
Height difference H (m)	Indoor Upper than Outdoor	20				0.909	0.894	0.878
		15			0.939	0.923	0.907	0.892
		10		0.969	0.953	0.937	0.921	0.905
		5	0.995	0.979	0.963	0.947	0.931	0.915
	0		1.000	0.984	0.968	0.951	0.935	0.919
	Outdoor Upper than Indoor	-5	1.000	0.984	0.968	0.951	0.935	0.919
		-10		0.984	0.968	0.951	0.935	0.919
		-15			0.968	0.951	0.935	0.919
		-20				0.951	0.935	0.919
	Heating			5	10	15	20	25
Height difference H (m)	Indoor Upper than Outdoor	20				0.984	0.978	0.973
		15			0.989	0.984	0.978	0.973
		10		0.995	0.989	0.984	0.978	0.973
		5	1.000	0.995	0.989	0.984	0.978	0.973
	0		1.000	0.995	0.989	0.984	0.978	0.973
	Outdoor Upper than Indoor	-5	0.992	0.987	0.981	0.976	0.970	0.965
		-10		0.979	0.973	0.968	0.963	0.957
		-15			0.966	0.960	0.955	0.950
		-20				0.953	0.947	0.942

Model	36K		Pipe Length (m)					
Cooling			5	10	20	30	40	50
Height difference H (m)	Indoor Upper than Outdoor	30				0.868	0.833	0.797
		20			0.917	0.881	0.845	0.809
		10		0.967	0.931	0.894	0.858	0.822
		5	0.995	0.977	0.940	0.903	0.867	0.830
	0		1.000	0.982	0.945	0.908	0.871	0.834
	Outdoor Upper than Indoor	-5	1.000	0.982	0.945	0.908	0.871	0.834
		-10		0.982	0.945	0.908	0.871	0.834
		-20			0.945	0.908	0.871	0.834
		-30				0.908	0.871	0.834
Heating			5	10	20	30	40	50
Height difference H (m)	Indoor Upper than Outdoor	30				0.958	0.941	0.925
		20			0.975	0.958	0.941	0.925
		10		0.992	0.975	0.958	0.941	0.925
		5	1.000	0.992	0.975	0.958	0.941	0.925
	0		1.000	0.992	0.975	0.958	0.941	0.925
	Outdoor Upper than Indoor	-5	0.992	0.984	0.967	0.950	0.934	0.917
		-10		0.976	0.959	0.943	0.926	0.910
		-20			0.952	0.935	0.919	0.903
		-30				0.928	0.912	0.895

Model	48K		Pipe Length (m)					
Cooling			5	10	20	30	40	50
Height difference H (m)	Indoor Upper than Outdoor	30				0.867	0.831	0.795
		20			0.916	0.880	0.844	0.808
		10		0.967	0.930	0.893	0.857	0.820
		5	0.995	0.976	0.939	0.902	0.865	0.828
	0		1.000	0.981	0.944	0.907	0.870	0.832
	Outdoor Upper than Indoor	-5	1.000	0.981	0.944	0.907	0.870	0.832
		-10		0.981	0.944	0.907	0.870	0.832
		-20			0.944	0.907	0.870	0.832
		-30				0.907	0.870	0.832
Heating			5	10	20	30	40	50
Height difference H (m)	Indoor Upper than Outdoor	30				0.953	0.934	0.916
		20			0.972	0.953	0.934	0.916
		10		0.991	0.972	0.953	0.934	0.916
		5	1.000	0.991	0.972	0.953	0.934	0.916
	0		1.000	0.991	0.972	0.953	0.934	0.916
	Outdoor Upper than Indoor	-5	0.992	0.983	0.964	0.945	0.927	0.908
		-10		0.975	0.956	0.938	0.919	0.901
		-20			0.949	0.930	0.912	0.894
		-30				0.923	0.905	0.887

Model	60K		Pipe Length (m)					
Cooling			5	10	20	30	40	50
Height difference H (m)	Indoor Upper than Outdoor	30				0.851	0.808	0.766
		20			0.906	0.864	0.821	0.778
		10		0.963	0.920	0.877	0.833	0.790
		5	0.995	0.973	0.929	0.886	0.842	0.798
	0		1.000	0.978	0.934	0.890	0.846	0.802
	Outdoor Upper than Indoor	-5	1.000	0.978	0.934	0.890	0.846	0.802
		-10		0.978	0.934	0.890	0.846	0.802
		-20			0.934	0.890	0.846	0.802
		-30				0.890	0.846	0.802
Heating			5	10	20	30	40	50
Height difference H (m)	Indoor Upper than Outdoor	30				0.950	0.930	0.910
		20			0.970	0.950	0.930	0.910
		10		0.990	0.970	0.950	0.930	0.910
		5	1.000	0.990	0.970	0.950	0.930	0.910
	0		1.000	0.990	0.970	0.950	0.930	0.910
	Outdoor Upper than Indoor	-5	0.992	0.982	0.962	0.942	0.922	0.902
		-10		0.974	0.954	0.935	0.915	0.895
		-20			0.947	0.927	0.907	0.888
		-30				0.920	0.900	0.881

8. Noise Criterion Curves

8.1 Indoor Unit

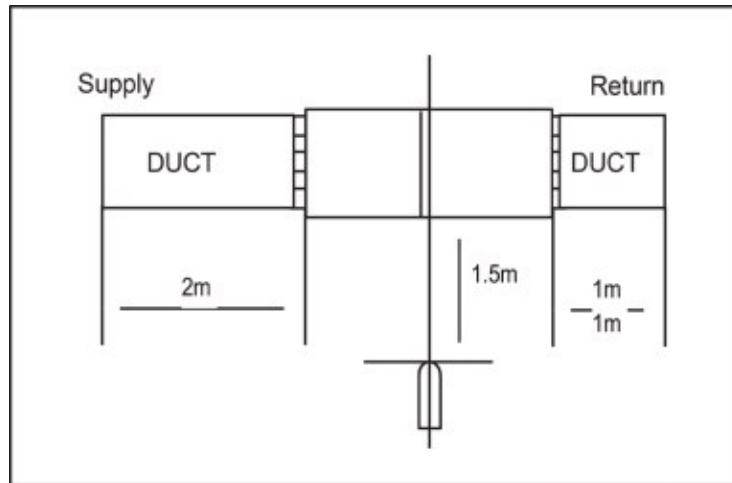

Notes:

- Sound measured at 1.5m away from the center of the unit.
- Data is valid at free field condition
- Data is valid at nominal operation condition
- Reference acoustic pressure $O_{dB} = 20\mu Pa$
- Sound level will vary depending on a range of factors such as the construction -(acoustic absorption coefficient) of particular room in which the equipment is installed.
- The operating conditions are assumed to be standard.

18k

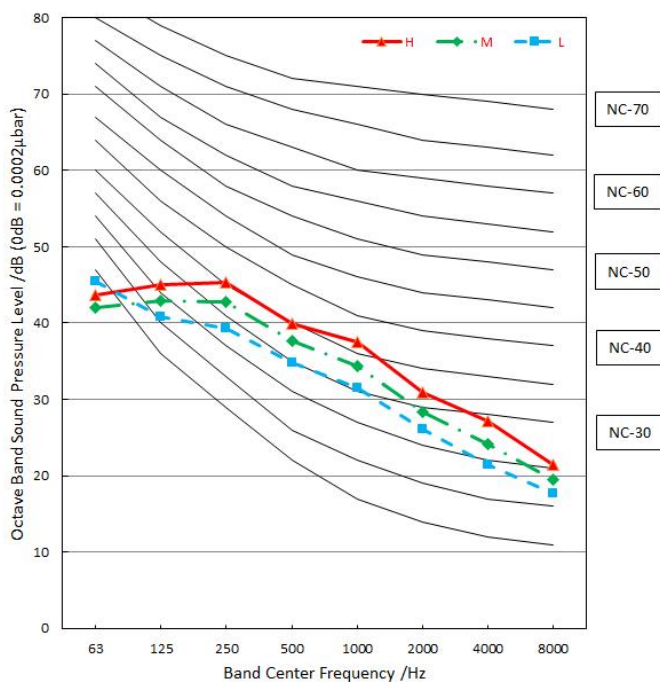

24k

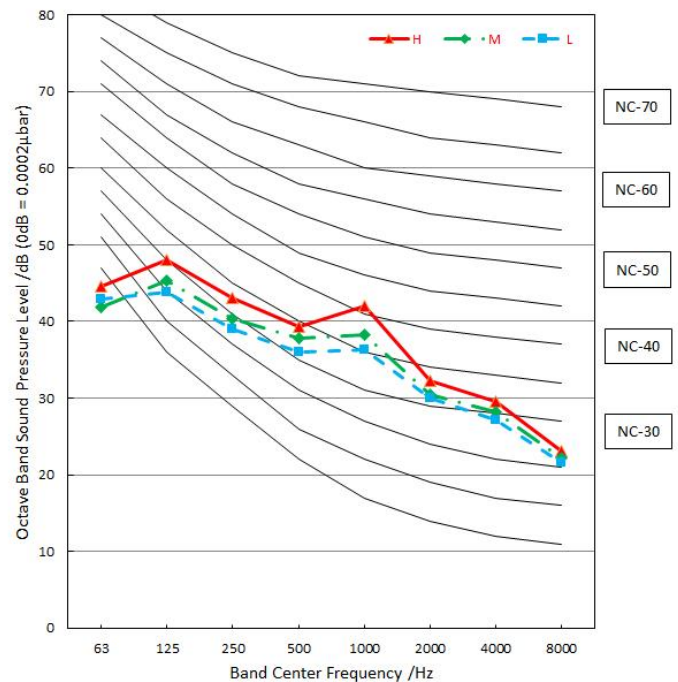

30k

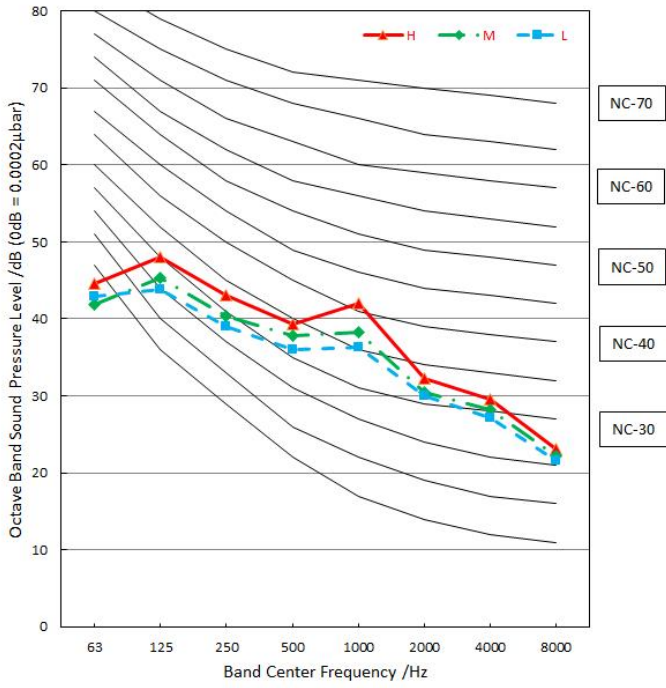

36k

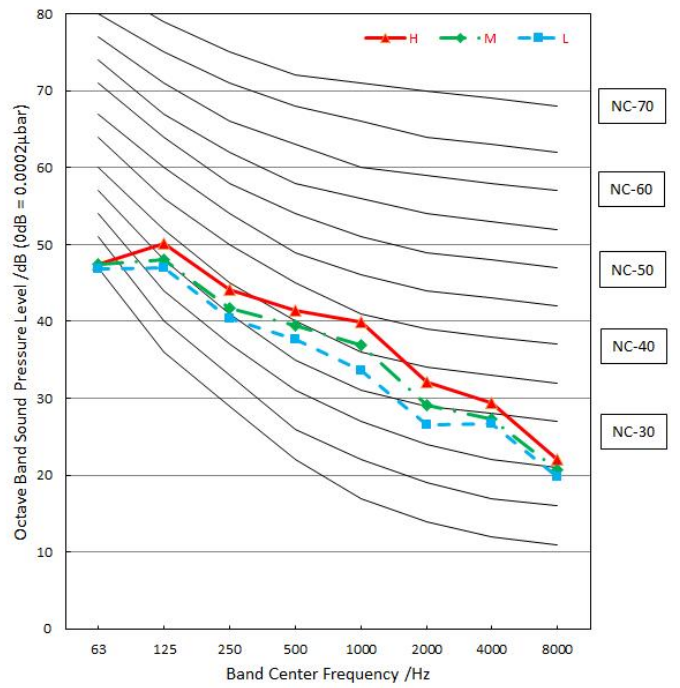

48k

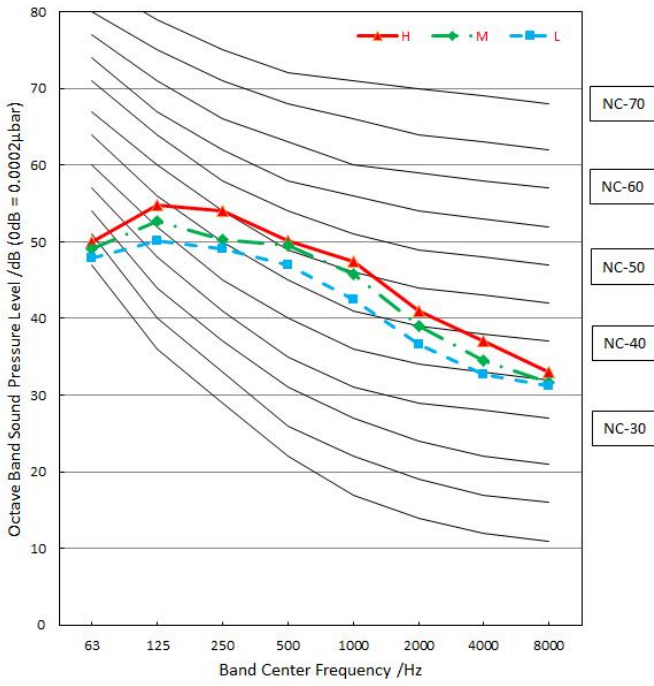

60k

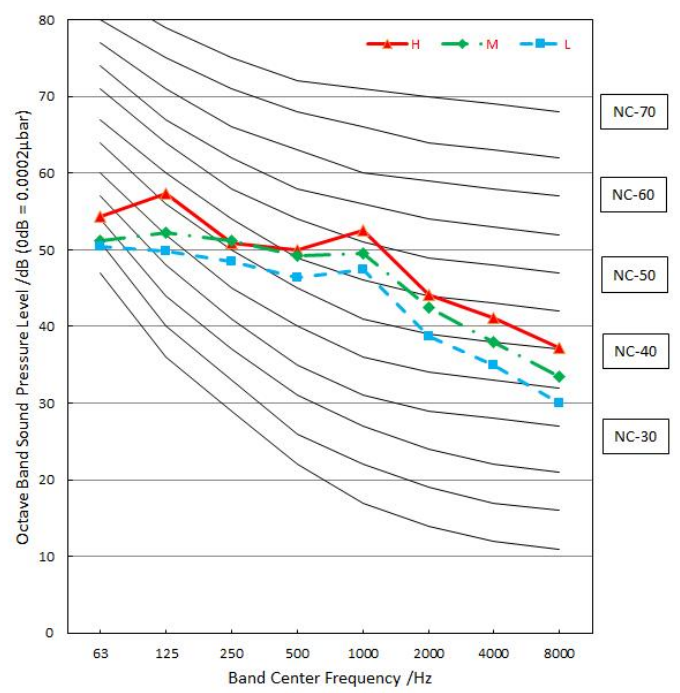

8.2 Outdoor Unit

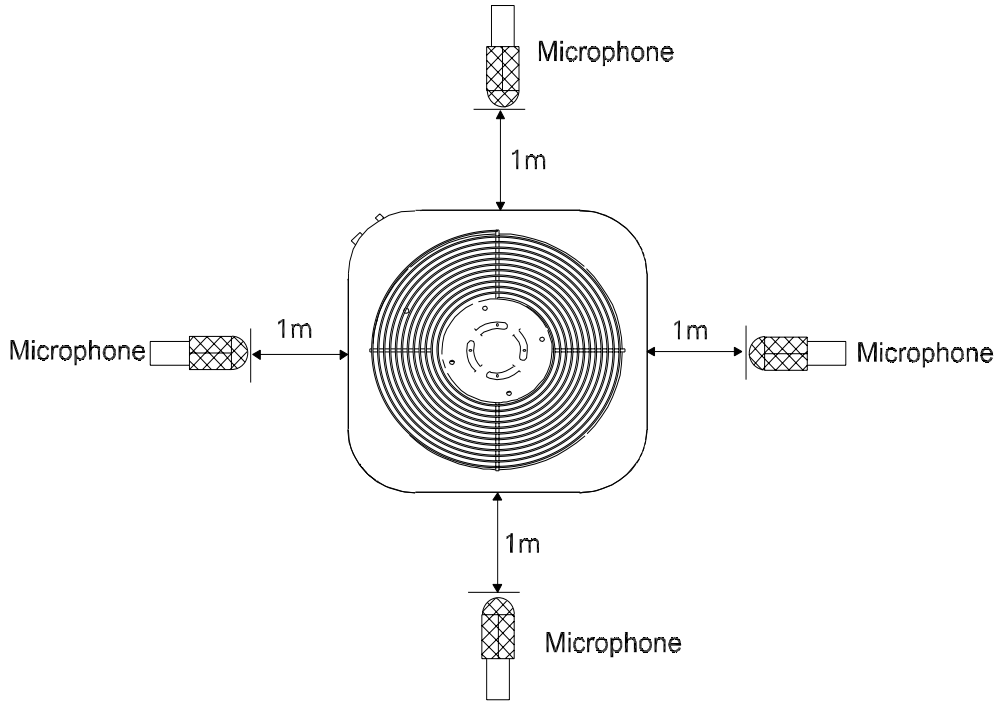

Notes:

- Sound measured at 1.0m away from the center of the unit, height of microphone is $0.5 \times (\text{height of outdoor unit} + 1)$.
- Data is valid at free field condition
- Data is valid at nominal operation condition
- Reference acoustic pressure $OdB = 20\mu Pa$
- Sound level will vary depending on arrange off actors such as the construction (acoustic absorption coefficient) of particular room in which the equipment is installed.
- The operating conditions are assumed to be standard.

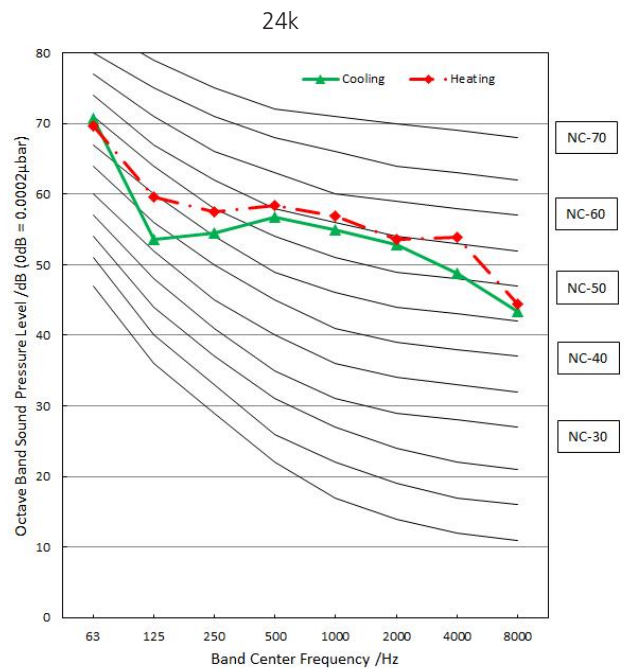
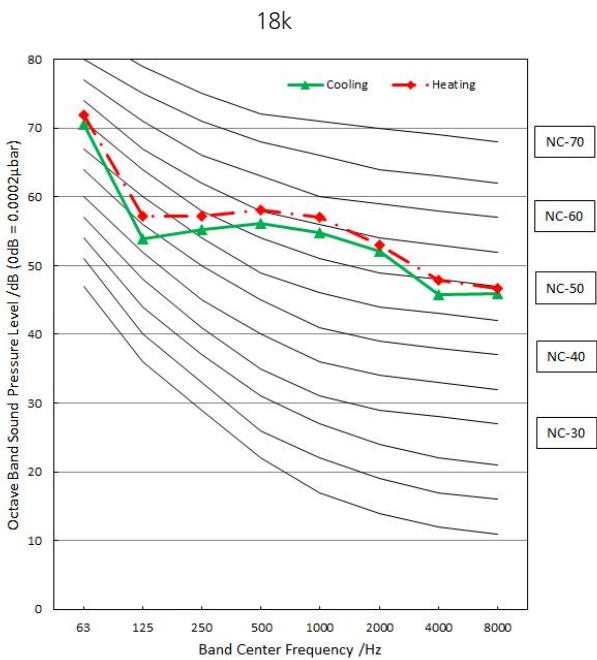

30k

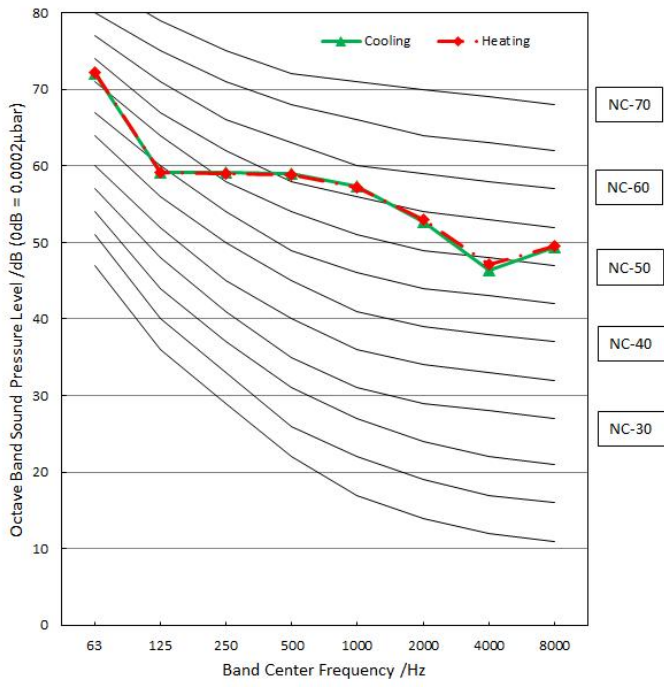

36k

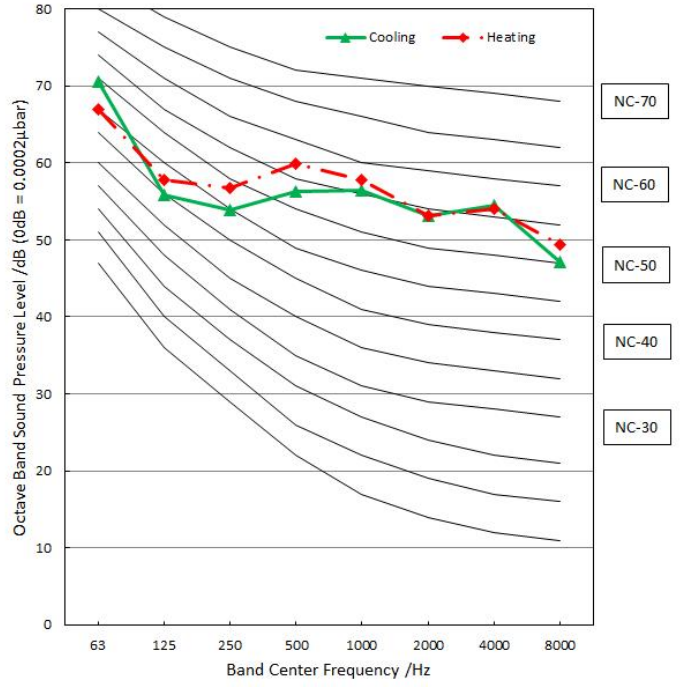

48k

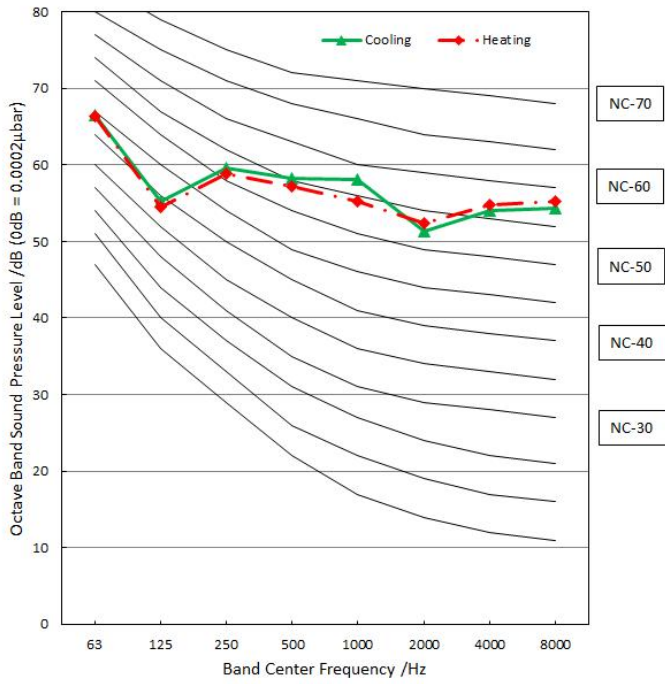

60k

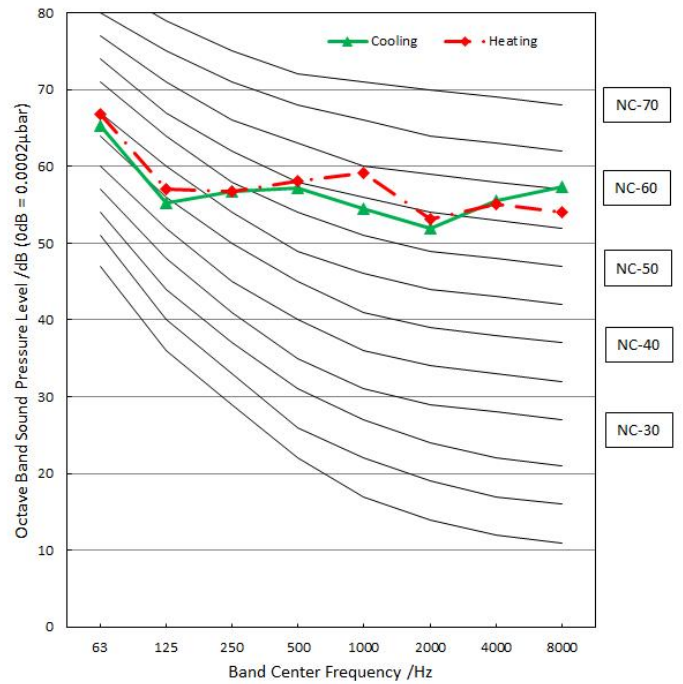

9. Electrical Characteristics

Capacity (Btu/h)		18k	24k	30k	36k	48k~60k
OUTDOOR UNIT POWER	Phase	1-phase	1-phase	1-phase	1-phase	3-phase
	Frequency and Voltage	220-240V, 50Hz	220-240V, 50Hz	220-240V, 50Hz	220-240V, 50Hz	380-415V, 50Hz
	Power Wiring (mm ²)	3×2.5	3×2.5	3×4.0	3×4.0	5×2.5
	Circuit Breaker/ Fuse (A)	25/20	25/20	40/30	40/30	32/25
Indoor/Outdoor Connecting Wiring	Weak Electric Signal)(mm ²)	/	/	/	/	/
	Strong Electric Signal)(mm ²)	4×1.0	4×1.0	4×1.0	4×1.0	4×1.5

10. Static Pressure

18k

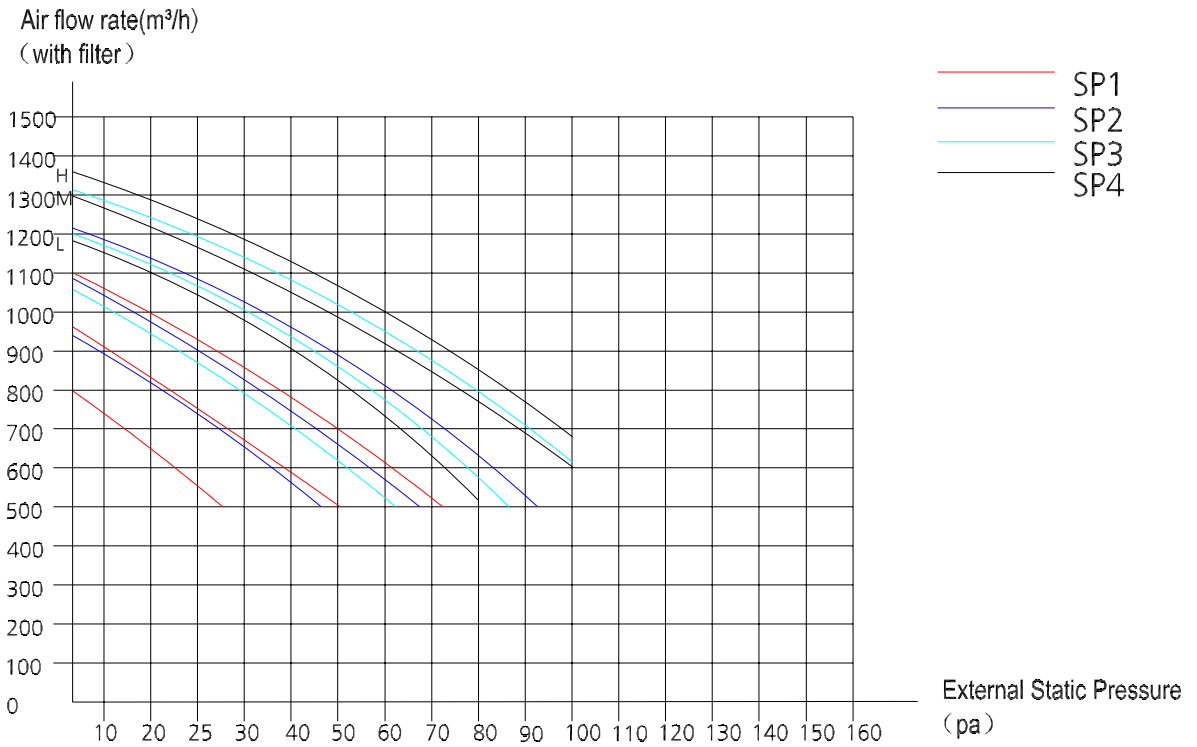

Constant air volume

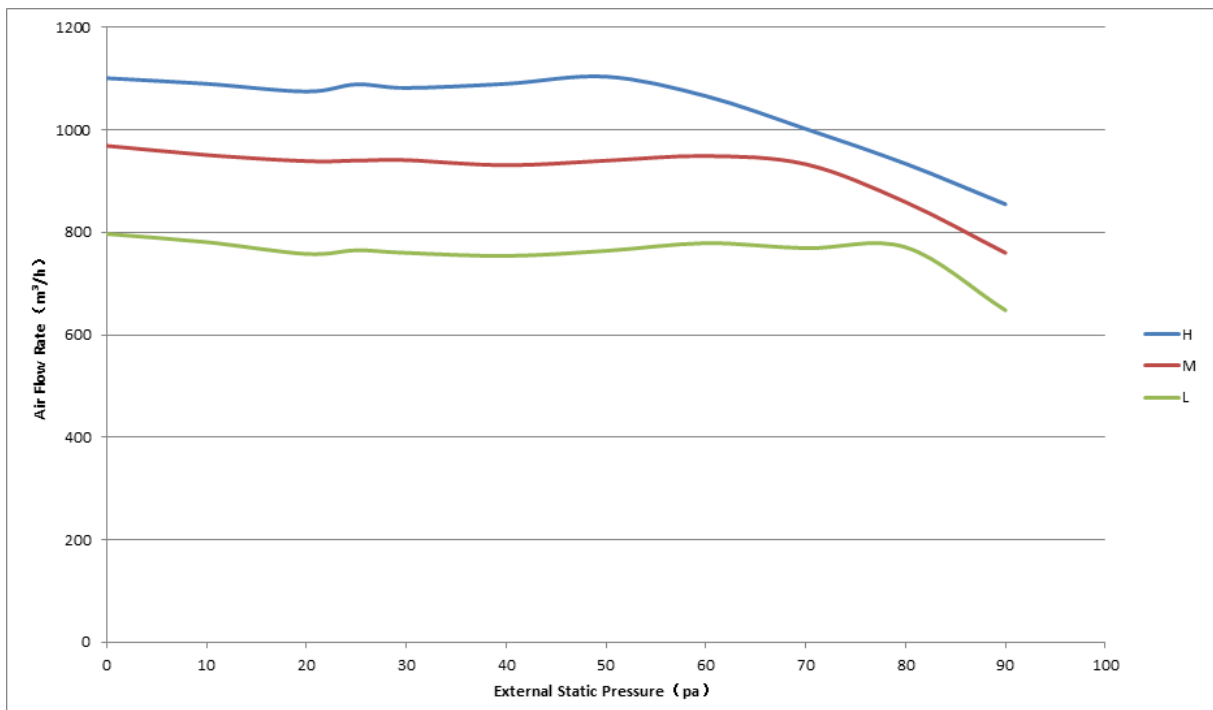

24k

Air flow rate(m³/h)
(with filter)

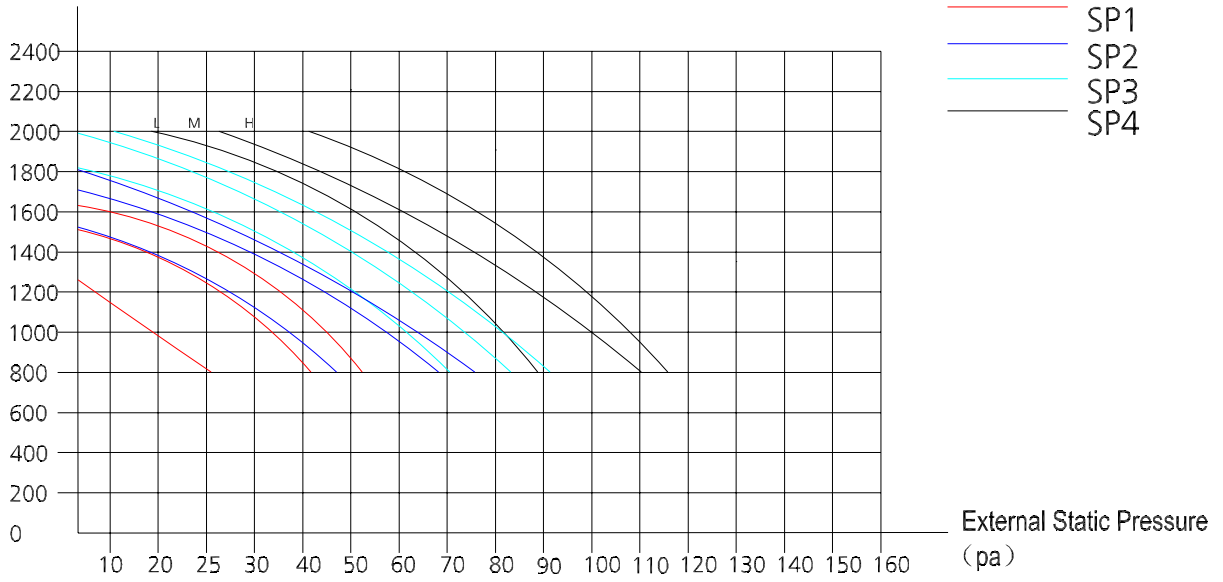

Constant air volume

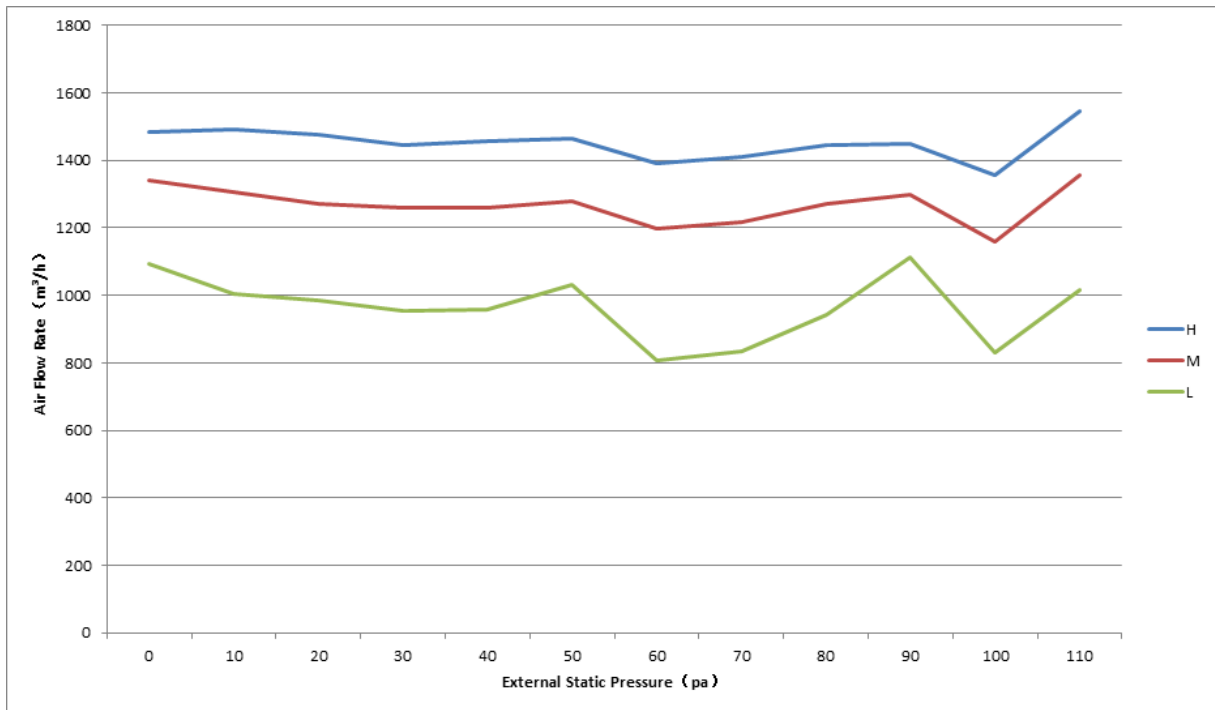

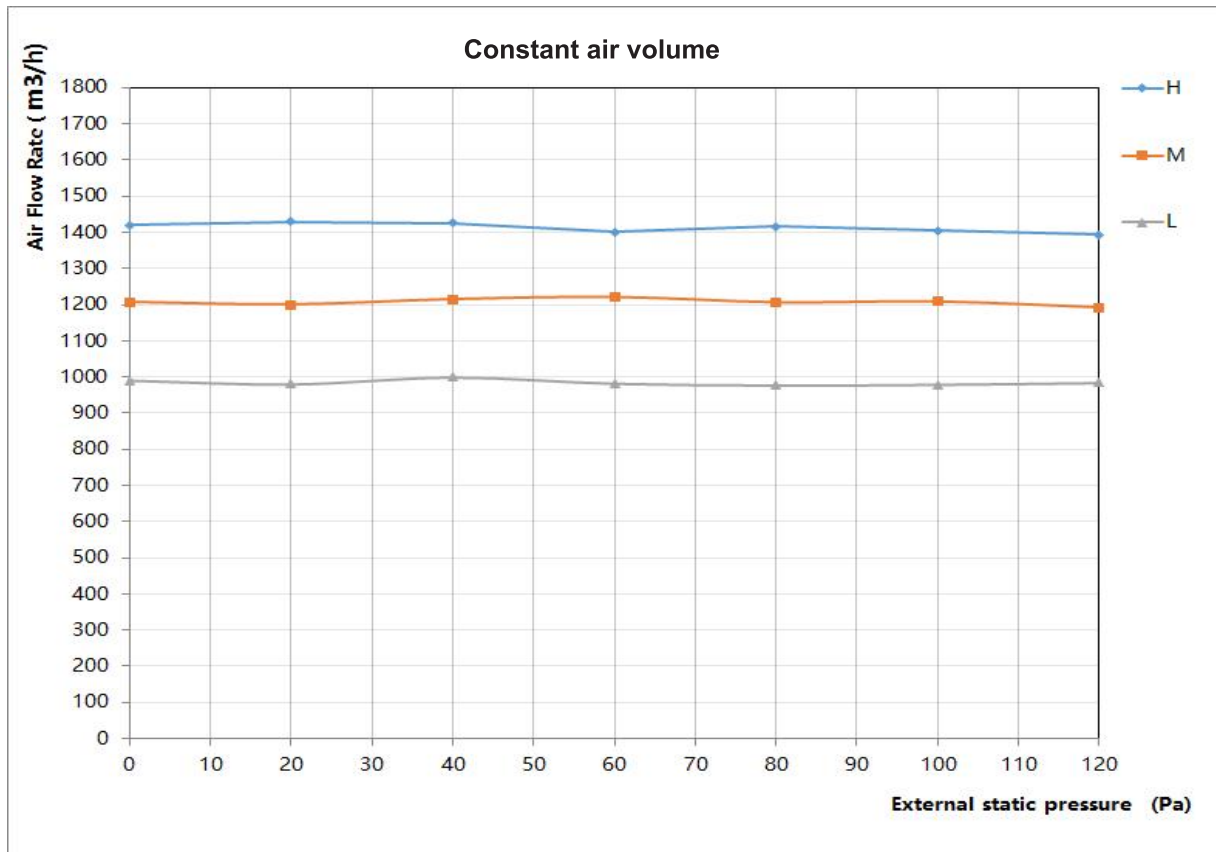
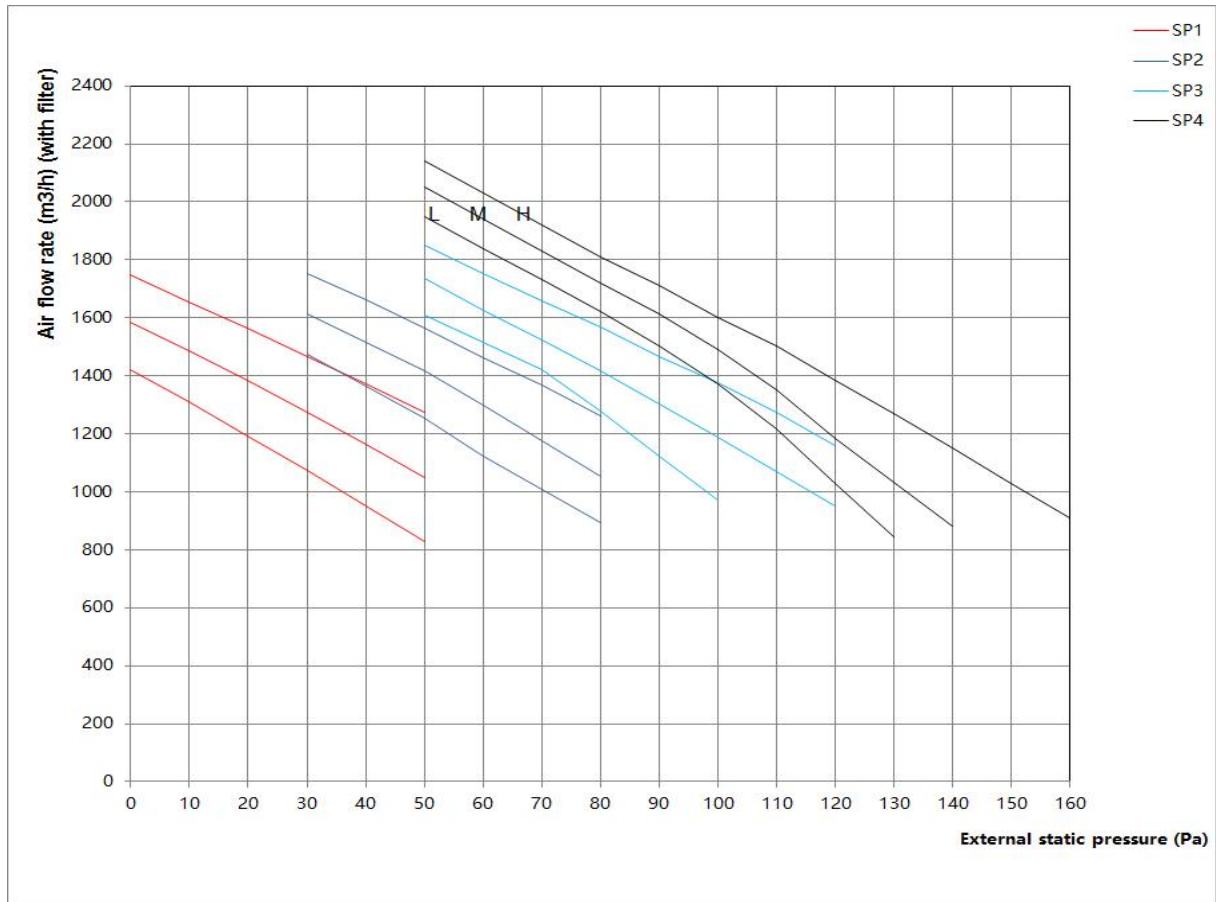

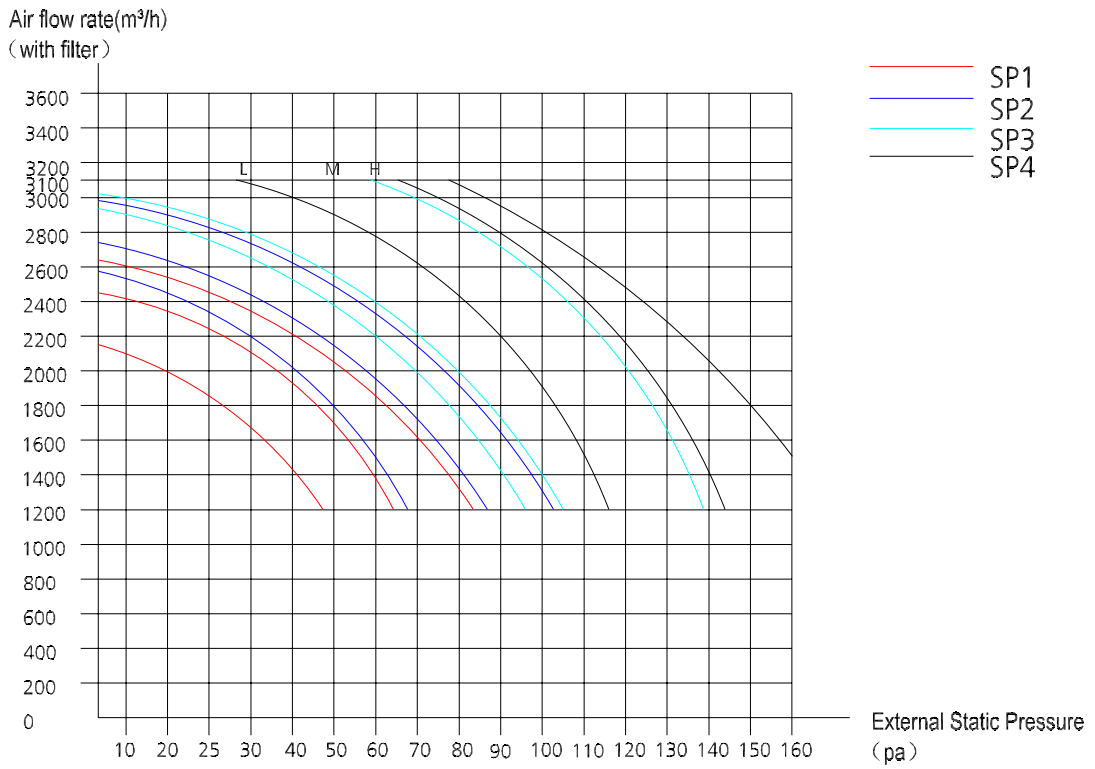

Constant air volume

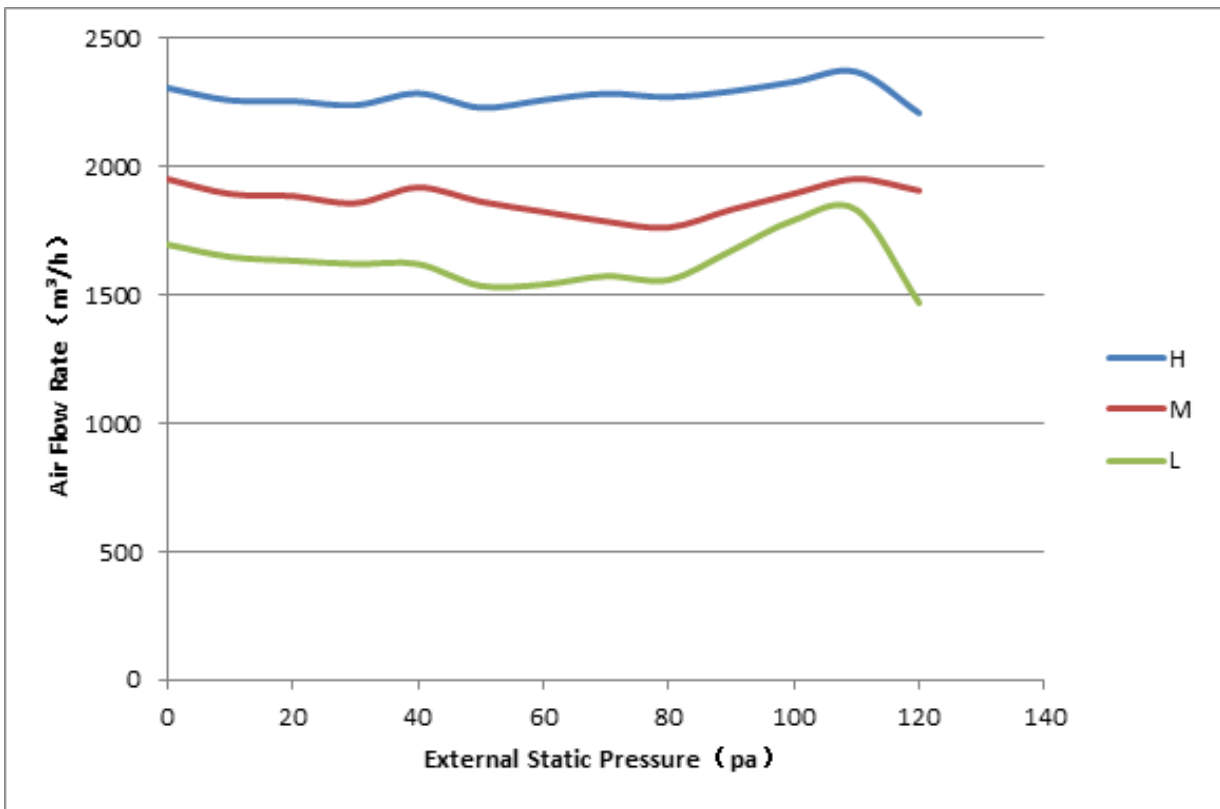

48k

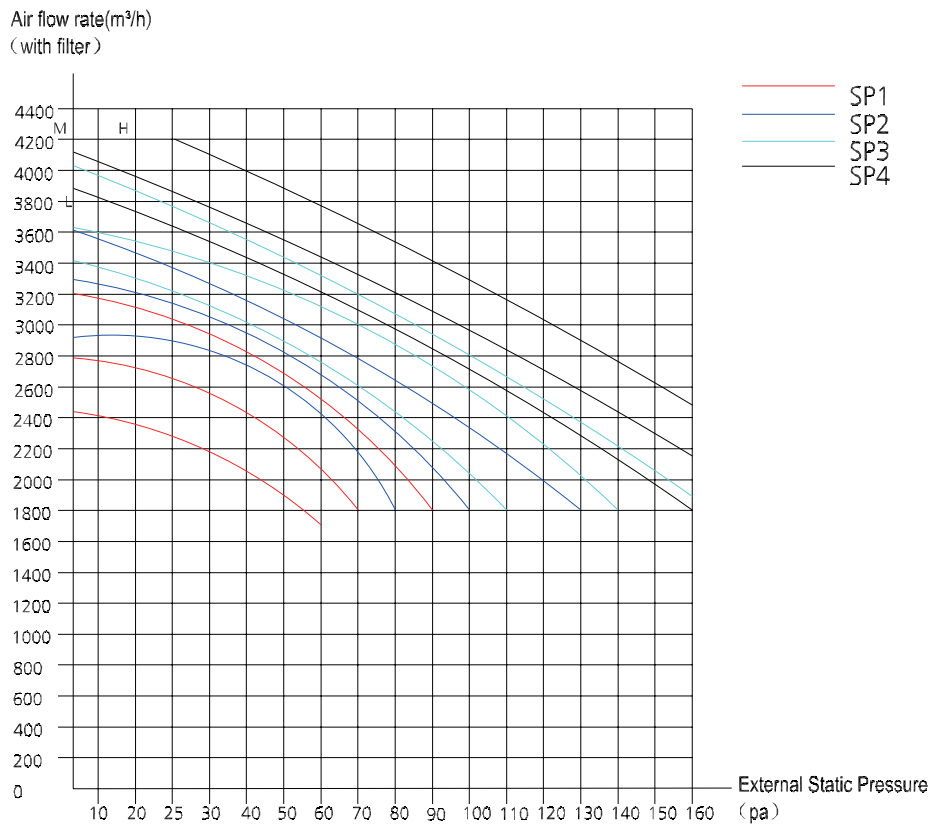

Constant air volume

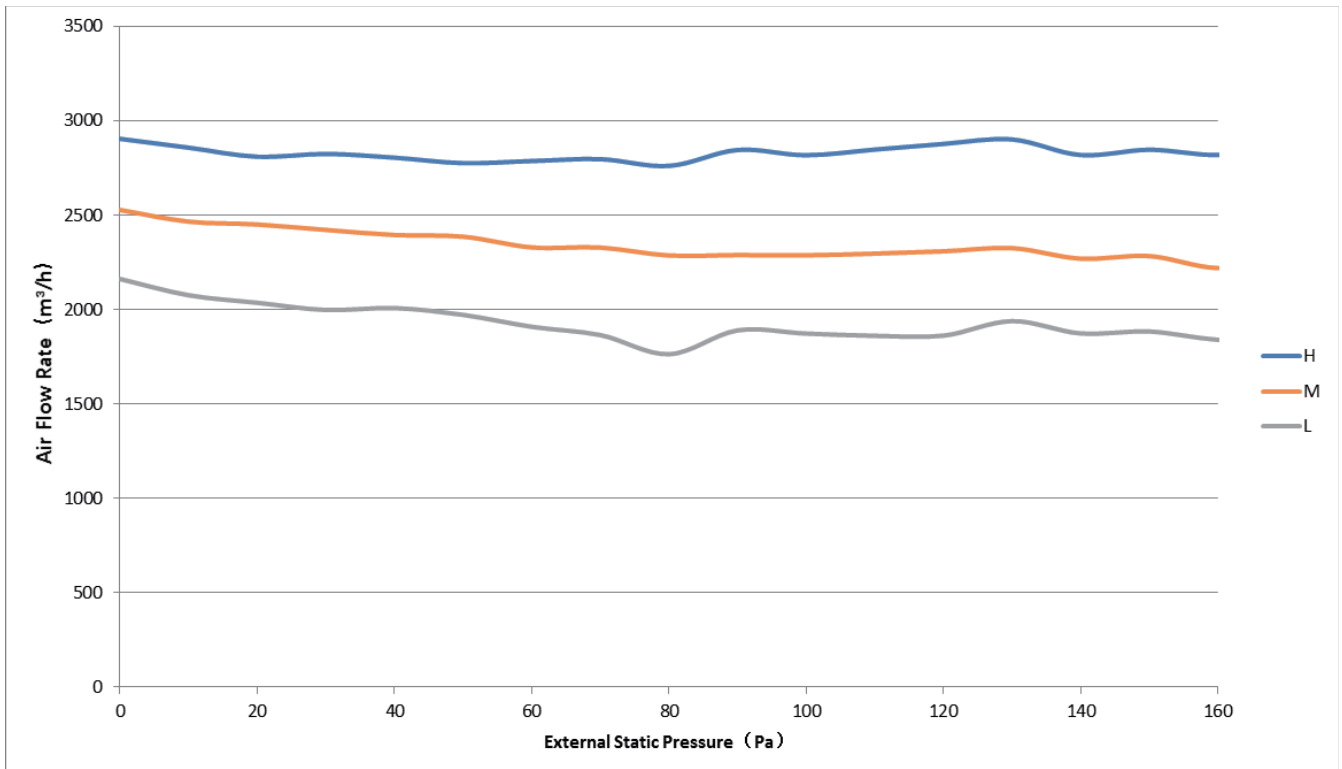

60k

Air flow rate(m³/h)
(with filter)

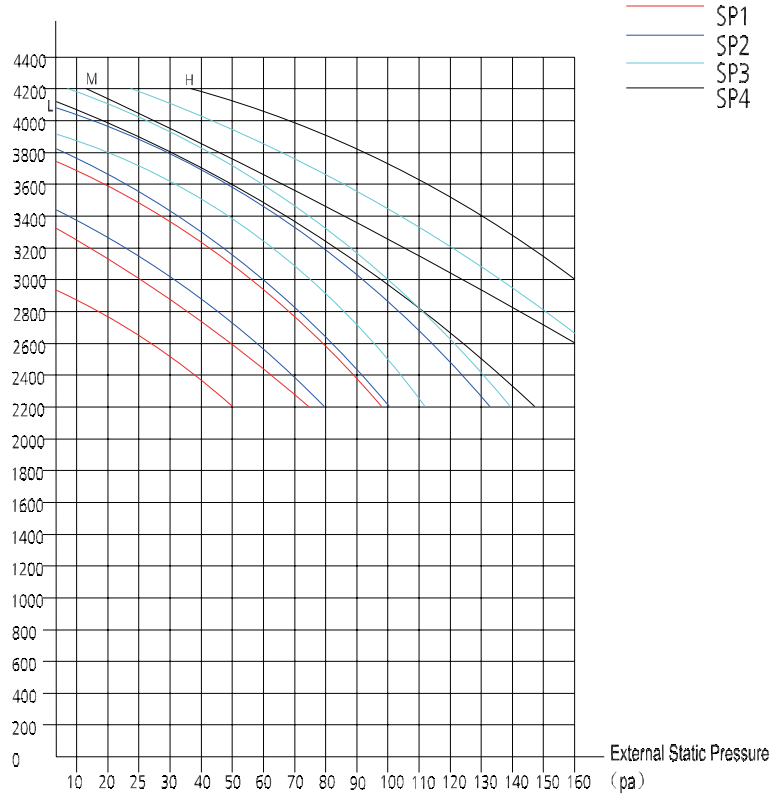

Constant air volume

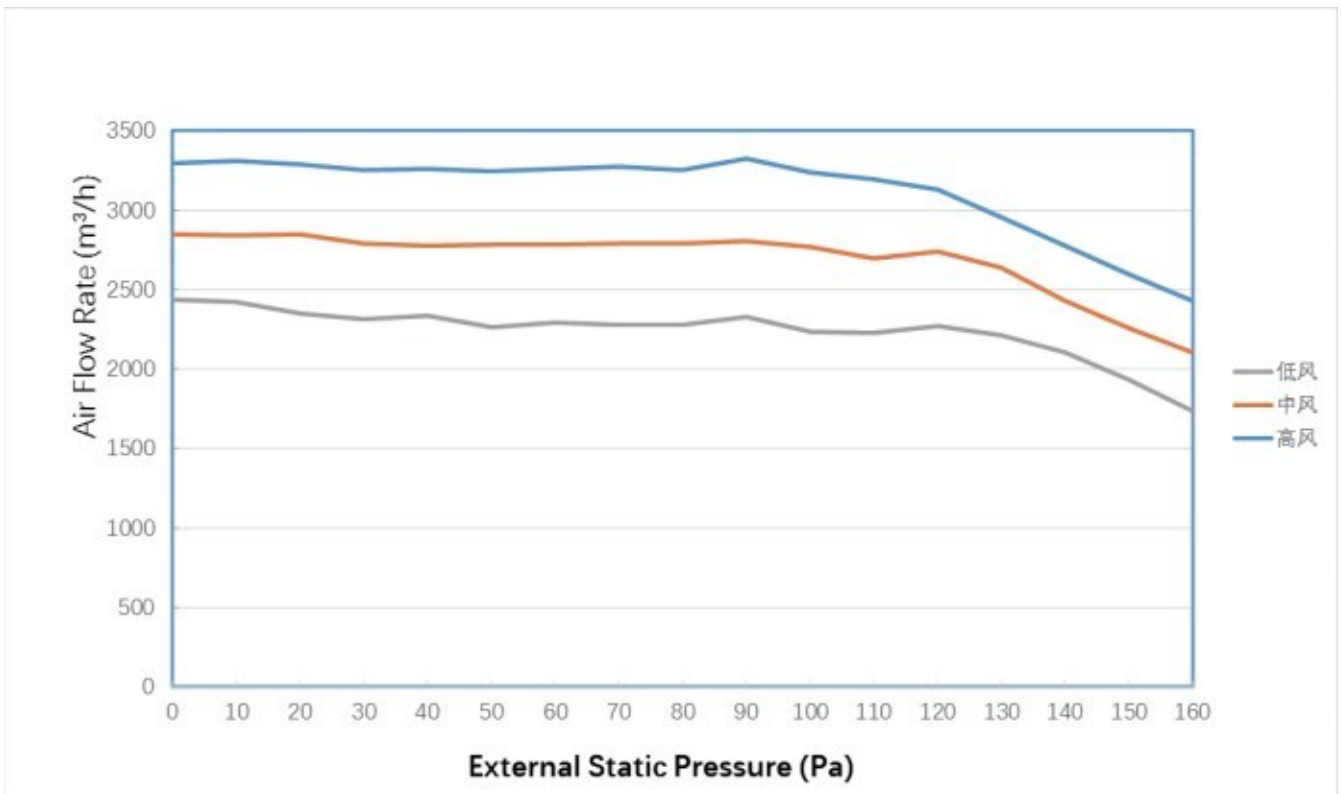

Chapter 2: Features

1.	Operation Modes and Functions	57
1.1	Abbreviations	57
1.2	Safety Features	57
1.3	Display Function	57
1.4	Fan.....	57
1.5	Cooling Mode	58
1.6	Heating Mode (Heat pump models).....	59
1.7	Auto Mode.....	60
1.8	Drying Mode.....	60
1.9	Forced Operation Function	60
1.10	Timer Function	60
1.11	ECO Function	61
1.12	Auto-Restart.....	61
1.13	8°C Heating(Optional)	61
1.14	Self clean(Optional)	61
1.15	Follow Me(Optional).....	61
1.16	Silence(Optional)	61
2.	Remote Controller Functions	62
2.1	LCD Wired Remote Controller	62
2.2	Centralized Controller	65
2.3	Using the wire controller to set external static pressure	66
2.4	Using the wire controller to set airflow rate	66

1. Operation Modes and Functions

1.1 Abbreviation

Unit element abbreviations

Abbreviation	Element
T1	Indoor room temperature
T2	Coil temperature of evaporator
T3	Coil temperature of condenser
T4	Outdoor ambient temperature
TP	Compressor discharge temperature
Tsc	Adjusted setting temperature

In this manual, such as CDIFTEMP, HDIFTEMP2, TCE1, TCE2...etc., they are well-setting parameter of EEPROM.

1.2 Safety Features

Compressor three-minute delay at restart

Compressor functions are delayed for up to ten seconds upon the first startup of the unit, and are delayed for up to three minutes upon subsequent unit restarts.

Automatic shutoff based on discharge temperature

If the compressor discharge temperature exceeds a certain level for nine seconds, the compressor ceases operation.

Automatic shutoff based on fan speed

If a fault occurs on the air volume regulator or the regulator enters protection mode, it sends the error message CF and an instruction to reduce fan speed to the master. The message and the instruction can be inquired with the remote controller or the wired controller. (Fault and protection information are displayed for one minute). After a fault occurs, the master unit shows the error code E3 and the fault count for one minute. If the fault occurs three times, then the fan is unable to resolve the problem independently. External shutdown by a remote controller, wired controller, or central controller must be used to clear the fan fault and fault count. The fan runs normally for 5 minutes while clearing fault count.

0	No malfunction
1	P0 Overcurrent
2	Overpressure
3	Overload
4	Over speed
5	Startup malfunction
6	Lack of phase

7	DC voltage too low
8	Communication fault
9	Parameter fault
10	L3 Current limited
11	L5 Voltage limited
12	Target speed cannot be met during the static pressure calculation process

Inverter module protection

The inverter module has an automatic shutoff mechanism based on the unit's current, voltage, and temperature. If automatic shutoff is initiated, the corresponding error code is displayed on the indoor unit and the unit ceases operation.

Indoor fan delayed operation

- When the unit starts, the louver is automatically activated and the indoor fan will operate after a period of setting time or the louver is in place.
- If the unit is in heating mode, the indoor fan is regulated by the anti-cold wind function.

Compressor preheating

Preheating is automatically activated when T4 sensor is lower than setting temperature.

Sensor redundancy and automatic shutoff

- If one temperature sensor malfunctions, the air conditioner continues operation and displays the corresponding error code, allowing for emergency use.
- When more than one temperature sensor is malfunctioning, the air conditioner ceases operation.

1.3 Display Function

Unit display functions

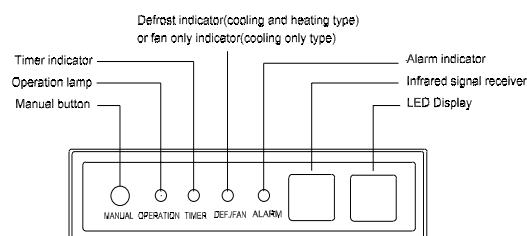

1.4 Fan Mode

When fan mode is activated:

- The outdoor fan and compressor are stopped.
- Temperature control is disabled and no temperature

setting is displayed.

- The indoor fan speed can be set to 1%~100%, or low, medium, high and auto.
- The louver operations are identical to those in cooling mode.
- Auto fan: In fan-only mode, AC operates the same as auto fan in cooling mode with the temperature set at 24°C.

1.5 Cooling Mode

1.5.1 Compressor Control

Reach the configured temperature:

- 1) When the compressor runs continuously for less than 120 minutes.
 - If the following conditions are satisfied, the compressor ceases operation.
 - Calculated frequency(fb) is less than minimum limit frequency(FminC).
 - Compressor runs at FminC more than ten minutes.
 - T1 is lower than or equal to (Tsc-CDIFTEMP-0.5°C)
- 2) When the compressor runs continuously for more than 120 minutes.
 - If the following conditions are satisfied, the compressor ceases operation.
 - Calculated frequency(fb) is less than minimum limit frequency(FminC).
 - Compressor runs at FminC more than 10 minutes.
 - When T1 is lower than or equal to (Tsc-CDIFTEMP).
- 3) If one of the following conditions is satisfied, not judge protective time.
 - Compressor running frequency is more than test frequency.
 - When compressor running frequency is equal to test frequency, T4 is more than 15°C or T4 fault.
 - Change setting temperature.
 - Turbo or sleep function on/off
 - Various frequency limit shutdown occurs.

1.5.2 Indoor Fan Control

- 1) In cooling mode, the indoor fan operates continuously. The fan speed can be set to 1%-100%, or low, medium, high and auto.
- 2) Auto fan action in cooling mode:
 - Descent curve
 - When T1-Tsc is lower than or equal to 3.5°C, fan speed reduces to 80%;
 - When T1-Tsc is lower than or equal to 1°C, fan speed reduces to 60%;

- When T1-Tsc is lower than or equal to 0.5°C, fan speed reduces to 40%;
- When T1-Tsc is lower than or equal to 0°C, fan speed reduces to 20%;
- When T1-Tsc is lower than or equal to -0.5°C, fan speed reduces to 1%.
- Rise curve
 - When T1-Tsc is higher than 0°C, fan speed increases to 20%;
 - When T1-Tsc is higher than 0.5°C, fan speed increases to 40%;
 - When T1-Tsc is higher than 1°C, fan speed increases to 60%;
 - When T1-Tsc is higher than 1.5°C, fan speed increases to 80%;
 - When T1-Tsc is higher than 4°C, fan speed increases to 100%.

1.5.3 Outdoor Fan Control

- The outdoor unit will be run at different fan speed according to T4 and compressor frequency.
- For different outdoor units, the fan speeds are different.

1.5.4 Condenser Temperature Protection

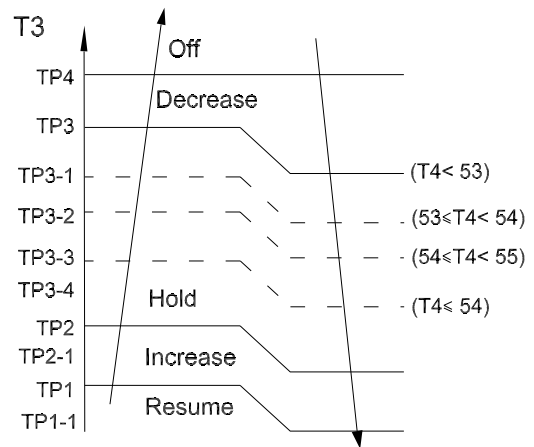

When the condenser temperature exceeds a configured value, the compressor ceases operation.

1.5.5 Evaporator Temperature Protection

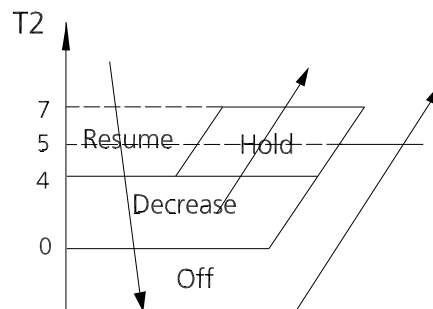

- Off: Compressor stops.
- Decrease: Decrease the running frequency to the lower level per 1 minute.
- Hold: Keep the current frequency.
- Resume: No limitation for frequency.

1.6 Heating Mode(Heat Pump Units)

1.6.1 Compressor Control

- 1) Reach the configured temperature
 - If the following conditions are satisfied, the compressor ceases operation.
 - Calculated frequency(fb) is less than minimum limit frequency(FminH).
 - Compressor runs at FminH more than 10 minutes.
 - T1 is higher than or equal to Tsc+ HDIFTEMP2.

Note: HDIFTEMP2 is EEPROM setting parameter. It is 2°C usually.

- If one of the following conditions is satisfied, not judge protective time.
 - Compressor running frequency is more than test frequency.
 - Compressor running frequency is equal to test frequency, T4 is more than 15°C or T4 fault.
 - Change setting temperature.
 - Turbo or sleep function on/off.
- 2) When the current is higher than the predefined safe value, surge protection is activated, causing the compressor to cease operations.

1.6.2 Indoor Fan Control

- 1) In heating mode, the indoor fan operates continuously. The fan speed can be set to 1%-100%, or low, medium, high and auto.
 - Anti-cold air function
 - The indoor fan is controlled by the indoor temperature T1 and indoor unit coil temperature T2.

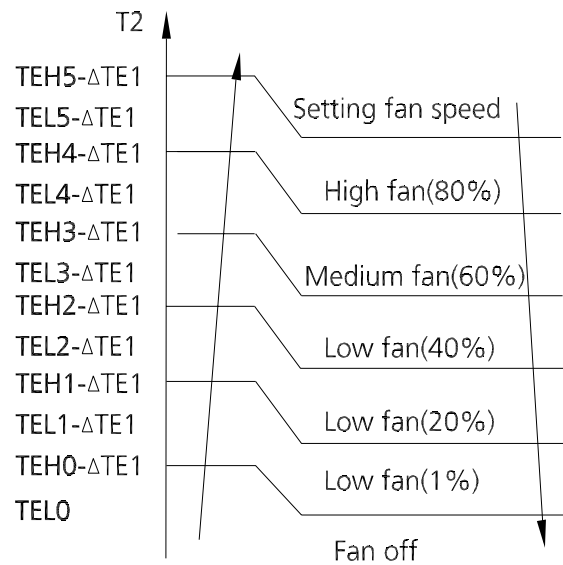

$\Delta TE1=0$

- 2) Auto fan action in heating mode:

- Rise curve
 - When T1-Tsc is higher than -1.5°C, fan speed reduces to 80%;
 - When T1-Tsc is higher than 0°C, fan speed reduces to 60%;
 - When T1-Tsc is higher than 0.5°C, fan speed reduces to 40%;
 - When T1-Tsc is higher than 1°C, fan speed reduces to 20%.
- Descent curve
 - When T1-Tsc is lower than or equal to 0.5°C, fan speed increases to 20%;
 - When T1-Tsc is lower than or equal to 0°C, fan speed increases to 60%;
 - When T1-Tsc is lower than or equal to -1.5°C, fan speed increases to 80%;
 - When T1-Tsc is lower than or equal to -3°C, fan speed increases to 100%.

1.6.3 Outdoor Fan Control

- The outdoor unit will be run at different fan speed according to T4 and compressor frequency.
- For different outdoor units, the fan speeds are different.

1.6.4 Defrosting mode

- The unit enters defrosting mode according to the temperature value of T3 and T4 as well as the compressor running time.
- In defrosting mode, the compressor continues to run, the indoor and outdoor motor will cease operation, the defrost light of the indoor unit will turn on, and the "df" symbol is displayed.

- If any one of the following conditions is satisfied, defrosting ends and the machine switches to normal heating mode:
 - T3 rises above TCDE1.
 - T3 maintained above TCDE2 for 80 seconds.
 - Unit runs for 15 minutes consecutively in defrosting mode.
- If T4 is lower than or equal to -22°C and compressor running time is more than TIMING_DEFROST_TIME, if any one of the following conditions is satisfied, defrosting ends and the machine switches to normal heating mode:
 - Unit runs for 10 minutes consecutively in defrosting mode.
 - T3 rises above 10°C.

For some models:

- T3 is lower than 3°C(37.4°F) and compressor running time is more than 120 minutes, at this time, if T3 is lower than TCDI1+4°C(39.2°F) for 3 minutes, the unit enters defrosting mode. If any one of the following conditions is satisfied, defrosting ends and the machine switches to normal heating mode:
 - T3 rises above TCDE1+4°C.
 - T3 maintained above TCDE2+4°C for 80 seconds.
 - Unit runs for 15 minutes consecutively in defrosting mode.

1.6.5 Evaporator Coil Temperature Protection

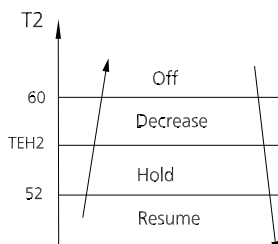

- Off: Compressor stops.
- Decrease: Decrease the running frequency to the lower level per 20 seconds.
- Hold: Keep the current frequency.
- Resume: No limitation for frequency.

1.7 Auto-mode

- This mode can be selected with the remote controller and the temperature setting can be adjusted between 16°C~30°C.
- In auto mode, the machine selects cooling, heating, or fan-only mode on the basis of ΔT ($\Delta T = T1 - TS$).

ΔT	Running mode
$\Delta T > 2^\circ\text{C} (3.6^\circ\text{F})$	Cooling
$-3^\circ\text{C} (-5.4^\circ\text{F}) \leq \Delta T \leq 2^\circ\text{C} (3.6^\circ\text{F})$	Fan-only
$\Delta T < -3^\circ\text{C} (-5.4^\circ\text{F})$	Heating*

Heating*: In auto mode, cooling only models run the fan

- Indoor fan will run at auto fan speed.
- The louver operates same as in relevant mode.
- If the machine switches mode between heating and cooling, the compressor will keep stopping for certain time and then choose mode according to ΔT .

1.8 Drying mode

- In drying mode, AC operates the same as auto fan in cooling mode.
- All protections are activated and operate the same as they do that in cooling mode.
- Low Room Temperature Protection

If the room temperature is lower than 10°C, the compressor ceases operations and does not resume until room temperature exceeds 12°C.

1.9 Forced operation function

Press the AUTO/COOL button, the AC will run as below sequence:

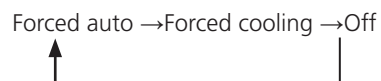

- Forced cooling mode:

The compressor and outdoor fan continue to run and the indoor fan runs at breeze speed. After running for 30 minutes, the AC will switch to auto mode with a preset temperature of 24°C(76°F).

- Forced auto mode:

Forced auto mode operates the same as normal auto mode with a preset temperature of 24°C(76°F).

- The unit exits forced operation when it receives the following signals:
 - Switch off
 - Changes in:
 - mode
 - fan speed
 - sleep mode
 - Follow me

1.10 Timer Function

- The timing range is 24 hours.
- Timer On. The machine turns on automatically at the preset time.

- Timer Off. The machine turns off automatically at the preset time.
- Timer On/Off. The machine turns on automatically at the preset On Time, and then turns off automatically at the preset Off Time.
- Timer Off/On. The machine turns off automatically at the preset Off Time and then turns on automatically at the preset On Time.
- The timer does not change the unit operation mode. If the unit is off now, it does not start up immediately after the "timer off" function is set. When the setting time is reached, the timer LED switches off and the unit running mode remains unchanged.
- The timer uses relative time, not clock time

1.11 ECO Function

- The ECO function is available in cooling, heating, or auto mode.
- The operational process for sleep mode is as follows:
 - When cooling, the temperature rises 1°C (to not higher than 30°C) every hour. After 2 hours, the temperature stops rising and the indoor fan is fixed at low speed.
 - When heating, the temperature decreases 1°C (to not lower than 17°C) every hour. After 2 hours, the temperature stops decreasing and the indoor fan is fixed at low speed. Anti-cold wind function takes priority.
- The operating time for sleep mode is 8 hours, after which, the unit exits this mode and does not switches off.

1.12 Auto-Restart function

- The indoor unit has an auto-restart module that allows the unit to restart automatically. The module automatically stores the current settings and in the case of a sudden power failure, will restore those setting automatically within 3 minutes after power returns.

1.13 8°C Heating(Optional)

In heating mode, the temperature can be set to as low as 8°C, preventing the indoor area from freezing if unoccupied during severe cold weather.

1.14 Self clean(Optional)

- If you press "Self Clean" when the unit is in cooling, drying, auto cooling or auto drying mode:
 - The indoor unit will run in low fan mode for a certain time, then ceases operation.

- Self Clean keeps the indoor unit dry and prevents mold growth.
- When match with multi outdoor unit, this function is disabled.

1.15 Follow me(Optional)

- If you press "Follow Me" on the remote, the indoor unit will beep. This indicates the follow me function is active.
- Once active, the remote control will send a signal every 3 minutes, with no beeps. The unit automatically sets the temperature according to the measurements from the remote control.
- The unit will only change modes if the information from the remote control makes it necessary, not from the unit's temperature setting.
- If the unit does not receive a signal for 7 minutes or you press "Follow Me," the function turns off. The unit regulates temperature based on its own sensor and settings.

1.16 Silence(Optional)

- Press "Silence" on the remote control to enable the SILENCE function. While this function is active, the compressor frequency is maintained at a lower level than F3. The indoor unit will run at faint breeze(1%), which reduces noise to the lowest possible level.
- When match with multi outdoor unit, this function is disabled.

2. Remote Controller Functions

2.1 LCD Wired Remote Controller

2.1.1 LCD Wired Remote Controller KJR-12B/DP(T) (Standard)

The KJR-12B/DP(T) wired remote controller is standard for Duct type.

i) Buttons and Functions

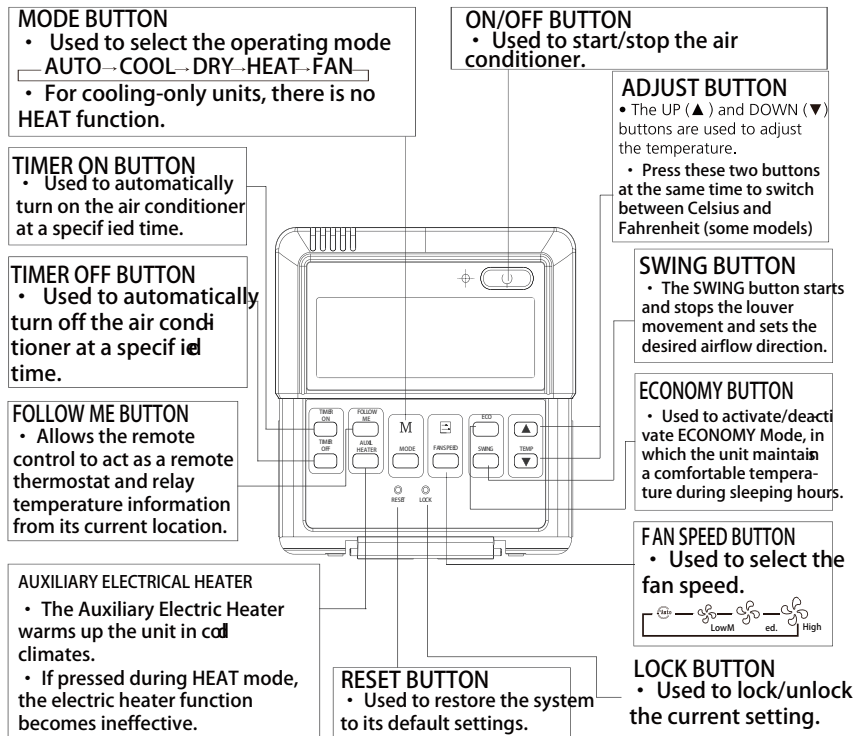

ii) LCD Screen

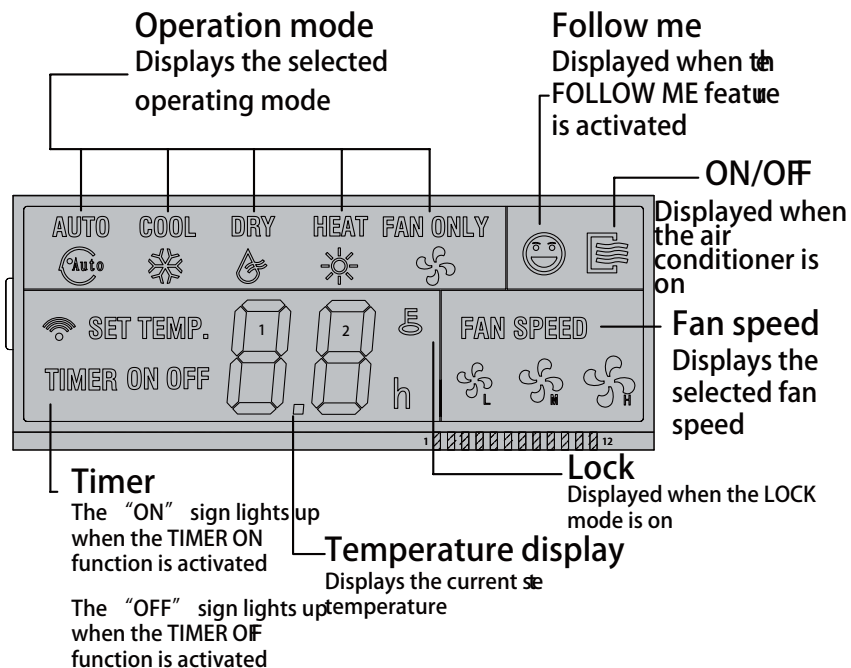

iii) Installation

- Dimensions

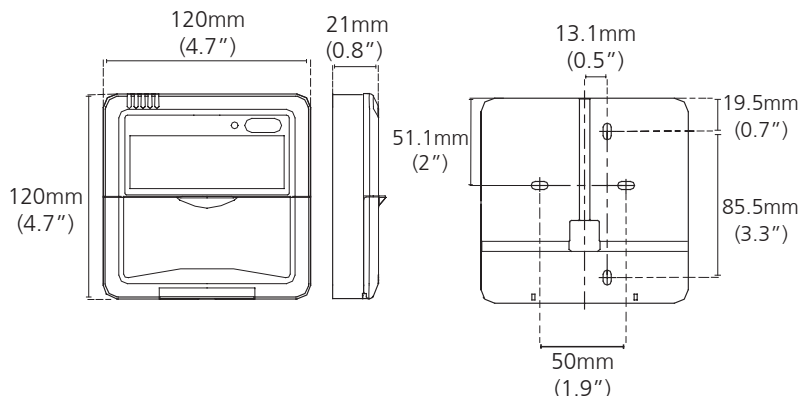

- Wiring diagram

Refer to the following diagram to wire the wall-mounted remote control to the indoor unit.

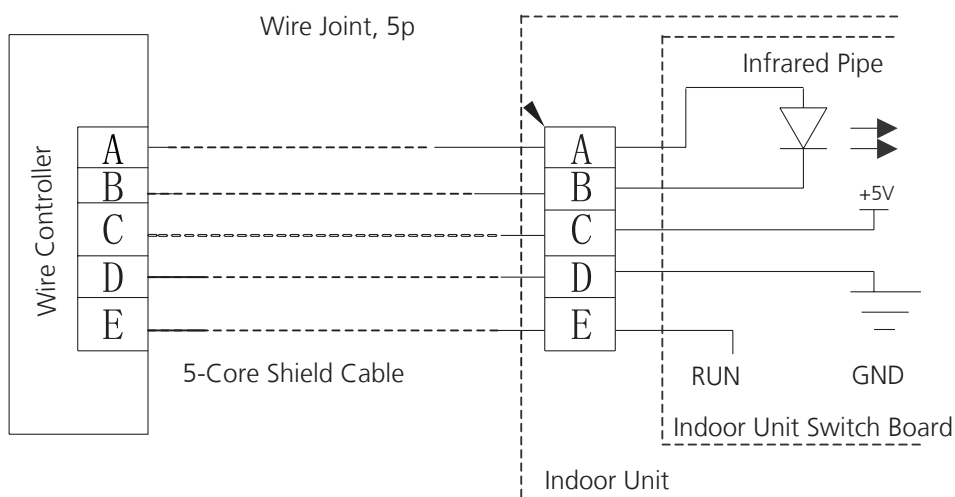

- Installation Diagram

Connect the wire from the display panel of the indoor unit to a connecting cable. Then connect the other side of the connecting cable to the remote control.

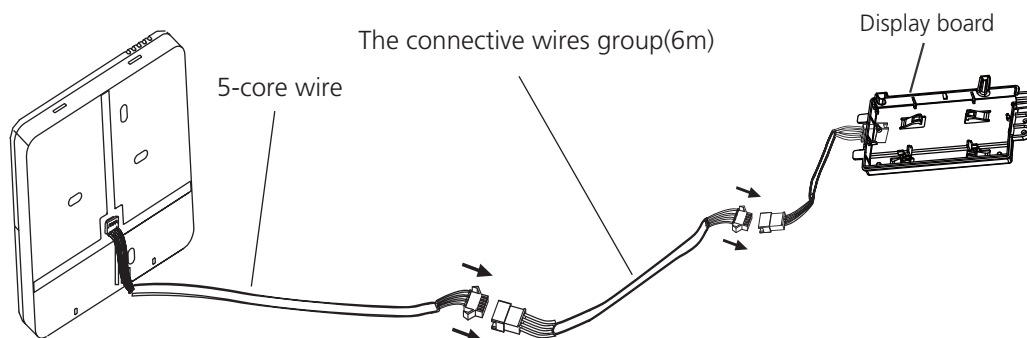

Note: Be sure to reserve a length of the connecting wire for periodic maintenance.

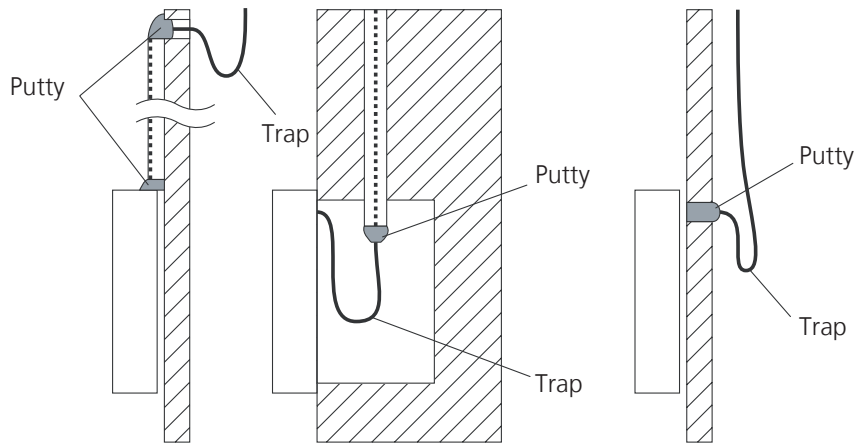

Note: DO NOT allow water to enter the remote control. Use the trap and putty to seal the wires.

- For exposed mounting, cut holes on four of the sides according to the picture below.

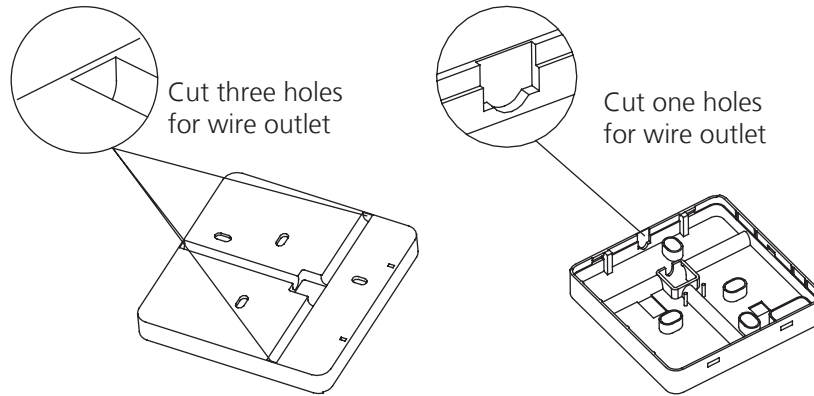

- For shielded wiring, please refer to the picture below.

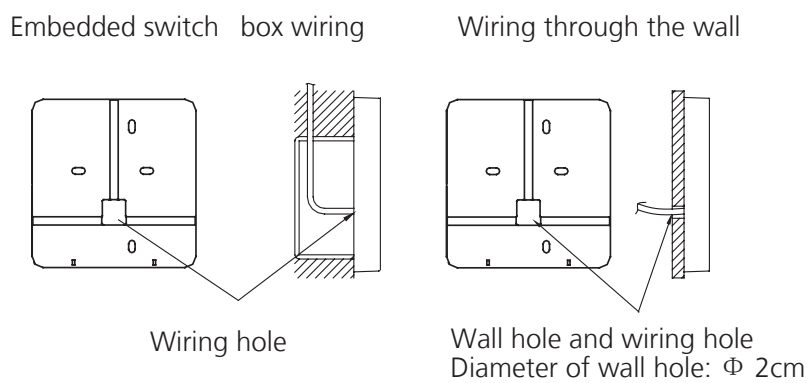

2.2 Centralized Controller

1) Connection

For Light commercial air conditioner with XYE port, it can be directly connected to Centralized Controller (CCM03, CCM09).

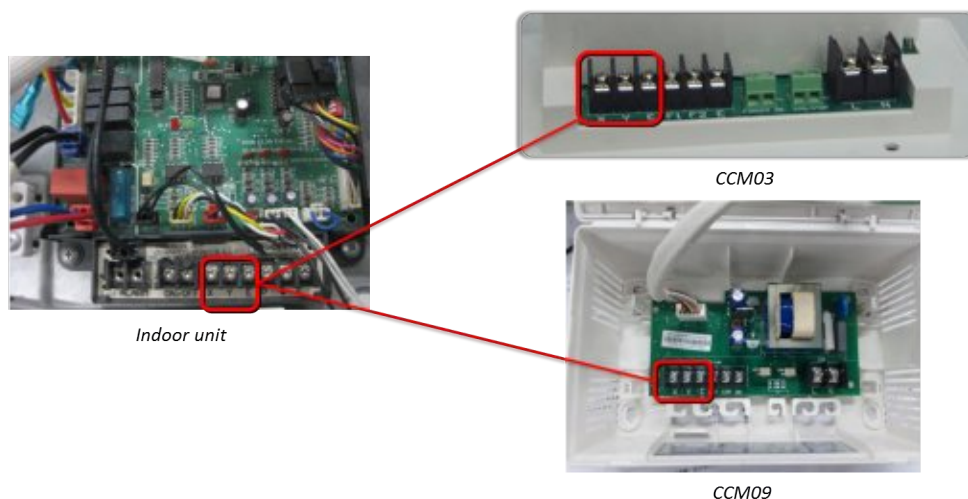

2) Address setting

When setting the address, please make sure the unit is powered off. The address can be set from 0 to 63 by the switch. Turn on the unit, then the address will be effective.

SWITCH		FOR CCM UNIT ADDRESS	
S2 + S1			
ADDRESS	0~15		16~31
Factory Setting	✓		
S2 + S1			
ADDRESS	32~47		48~63
Factory Setting			

Note: For light commercial air conditioner with XYE port, it can be also connected to BMS (Building Management System).

If there is any CAC (central air conditioner) connecting with the central controller at the same time, please set the address from largest (63,62,61...), since the CAC units could obtain address automatically from the smallest (00,01,02...)

2.3 Using the wire controller to set external static pressure

- You can use the unit's automatic airflow adjustment function to set external static pressure.
- Automatic airflow adjustment is the volume of blow-off air that has been automatically adjusted to the quantity rated.

1. Make sure the test run is done with a dry coil. If the coil is not dry, run the unit for 2 hours in FAN ONLY mode to dry the coil.

2. Check that both power supply wiring and duct installation have been completed. Check that any closing dampers are open. Check that the air filter is properly attached to the air suction side passage of the unit.

3. If there is more than one air inlet and outlet, adjust the dampers so that the airflow rate of each air inlet and outlet conforms with the designed airflow rate. Make sure the unit is in FAN ONLY mode. Press and set the airflow adjustment button on the remote control to change the airflow rate from H or L.

4. Set the parameters for automatic airflow adjustment. When the air conditioning unit is off, perform the following steps:

- When the unit is turned off, hold the MODE button and

FAN button down together for three seconds. ("AF" indicator flashes for 3 times.)

- Press "△" or "▽" to select the AF.

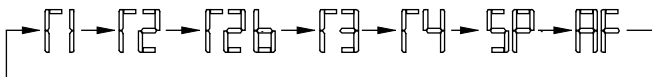

- Press "MODE". The air conditioning unit will then start the fan for airflow automatic adjustment.

After 3 to 6 minutes, the air conditioning unit stops operating once automatic airflow adjustment has finished.

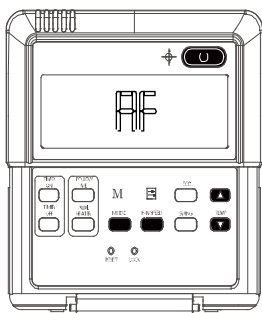

Caution: DO NOT adjust the dampers when automatic airflow adjustment is active.

Caution:

• If there is no change after airflow adjustment in the ventilation paths, be sure to reset automatic airflow adjustment.

• If there is no change to ventilation paths after airflow adjustment, contact your dealer, especially if this occurs after testing the outdoor unit or if the unit has been moved to a different location.

• Do not use automatic airflow adjustment with remote control, if you are using booster fans, outdoor air processing unit, or a HRV via duct.

• If the ventilation paths have been changed, reset airflow automatic adjustment as described from step 3 onwards.

2.4 Using the wire controller to set airflow rate

When the air conditioning unit is off, perform the following steps:

1. Press "MODE" and "FAN" for three seconds.

2. Press "△" or "▽" to select the SP.

3. Press "MODE" to set the airflow rate in the range of 0~4.

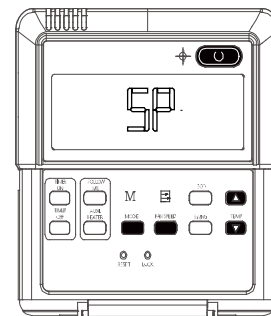

"0": No airflow change

"1" ~ "4": Airflow increase progressively

4. Press "ON/OFF" to finish the airflow setting.

Chapter 3: Static Pressure Design

1.	Introduction	68
2.	Charts for Friction Losses in Round Ducts.....	68
3.	Dynamic Losses.....	69
4.	Corresponding Relation Between Rectangular Duct and Round Duct	70
5.	Method for Duct Calculation	71
6.	Unit Conversion	71
7.	Recommended Outlet Velocity for Different Occasions	71

1. Introduction

Duct system losses are the irreversible transformation of mechanical energy into heat. The two types of losses are (1) friction losses and (2) dynamic losses.

Friction losses are due to fluid viscosity and result from momentum exchange between molecules (in laminar flow) or between individual particles of adjacent fluid layers moving at different velocities (in turbulent flow). Friction losses occur along the entire duct length.

Dynamic losses result from flow disturbances caused by duct mounted equipment and fittings (e.g., entries, exits, elbows, transitions, and junctions) that change the airflow path's direction or area.

2. Charts For Friction Losses In Round Ducts

Fluid resistance caused by friction in round ducts can be determined by the friction chart. (based on galvanized sheet)

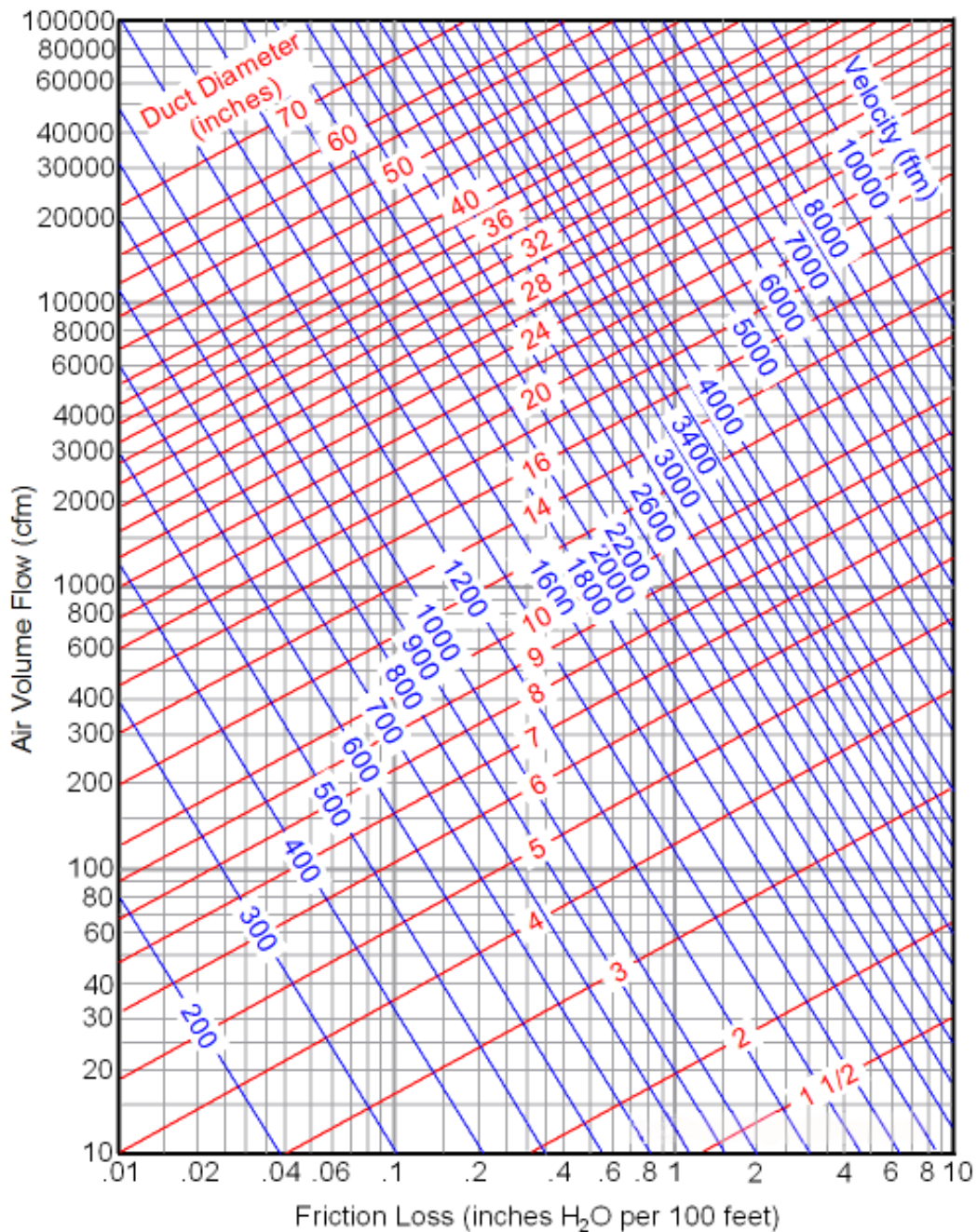

3. Dynamic Losses

For dynamic losses, please refer to below image.

$H' =$	<table border="1"> <thead> <tr> <th colspan="2">Elbow ($r/w = 1$)</th> </tr> <tr> <th>V m/s</th> <th>loss mm H₂O</th> </tr> </thead> <tbody> <tr> <td>3.5~5</td> <td>0.2</td> </tr> <tr> <td>5~7</td> <td>0.4</td> </tr> <tr> <td>7~9</td> <td>0.8^x</td> </tr> <tr> <td>9~15</td> <td>2</td> </tr> </tbody> </table>	Elbow ($r/w = 1$)		V m/s	loss mm H ₂ O	3.5~5	0.2	5~7	0.4	7~9	0.8 ^x	9~15	2	+	<table border="1"> <thead> <tr> <th colspan="2">Sharp elbow ($r/w = 0.5$)</th> </tr> <tr> <th>V m/s</th> <th>loss mm H₂O</th> </tr> </thead> <tbody> <tr> <td>3.5~5</td> <td>1</td> </tr> <tr> <td>5~7</td> <td>2</td> </tr> <tr> <td>7~9</td> <td>3.5^x</td> </tr> <tr> <td>9~15</td> <td>7</td> </tr> </tbody> </table>	Sharp elbow ($r/w = 0.5$)		V m/s	loss mm H ₂ O	3.5~5	1	5~7	2	7~9	3.5 ^x	9~15	7	+	<table border="1"> <thead> <tr> <th colspan="2">Branch Straight-Thru</th> </tr> </thead> <tbody> <tr> <td colspan="2">No friction loss</td> </tr> </tbody> </table>	Branch Straight-Thru		No friction loss		+	<table border="1"> <thead> <tr> <th colspan="2">Branch Thru-Branch ($r/w = 1$)</th> </tr> <tr> <th>V m/s</th> <th>loss mm H₂O</th> </tr> </thead> <tbody> <tr> <td>3.5~5</td> <td>0.4</td> </tr> <tr> <td>5~7</td> <td>0.8</td> </tr> <tr> <td>7~9</td> <td>1.5^x</td> </tr> <tr> <td>9~15</td> <td>3</td> </tr> </tbody> </table>	Branch Thru-Branch ($r/w = 1$)		V m/s	loss mm H ₂ O	3.5~5	0.4	5~7	0.8	7~9	1.5 ^x	9~15	3	+	<table border="1"> <thead> <tr> <th colspan="2">Reducer $\theta \leq 14^\circ$</th> </tr> <tr> <th>V m/s</th> <th>loss mm H₂O</th> </tr> </thead> <tbody> <tr> <td>3.5~5</td> <td>0.2</td> </tr> <tr> <td>5~7</td> <td>0.4</td> </tr> <tr> <td>7~9</td> <td>0.8^x</td> </tr> <tr> <td>9~15</td> <td>2</td> </tr> </tbody> </table>	Reducer $\theta \leq 14^\circ$		V m/s	loss mm H ₂ O	3.5~5	0.2	5~7	0.4	7~9	0.8 ^x	9~15	2
	Elbow ($r/w = 1$)																																																												
V m/s	loss mm H ₂ O																																																												
3.5~5	0.2																																																												
5~7	0.4																																																												
7~9	0.8 ^x																																																												
9~15	2																																																												
Sharp elbow ($r/w = 0.5$)																																																													
V m/s	loss mm H ₂ O																																																												
3.5~5	1																																																												
5~7	2																																																												
7~9	3.5 ^x																																																												
9~15	7																																																												
Branch Straight-Thru																																																													
No friction loss																																																													
Branch Thru-Branch ($r/w = 1$)																																																													
V m/s	loss mm H ₂ O																																																												
3.5~5	0.4																																																												
5~7	0.8																																																												
7~9	1.5 ^x																																																												
9~15	3																																																												
Reducer $\theta \leq 14^\circ$																																																													
V m/s	loss mm H ₂ O																																																												
3.5~5	0.2																																																												
5~7	0.4																																																												
7~9	0.8 ^x																																																												
9~15	2																																																												
	<table border="1"> <thead> <tr> <th colspan="2">Anemostat</th> </tr> <tr> <th>V m/s</th> <th>loss mm H₂O</th> </tr> </thead> <tbody> <tr> <td>3.5~5</td> <td>1</td> </tr> <tr> <td>5~7</td> <td>2</td> </tr> <tr> <td>7~9</td> <td>3.5</td> </tr> <tr> <td>9~15</td> <td>6</td> </tr> </tbody> </table>	Anemostat		V m/s	loss mm H ₂ O	3.5~5	1	5~7	2	7~9	3.5	9~15	6	+	<table border="1"> <thead> <tr> <th colspan="2">Gallery or louver</th> </tr> <tr> <th>V m/s</th> <th>loss mm H₂O</th> </tr> </thead> <tbody> <tr> <td>3.5~5</td> <td>0.5</td> </tr> <tr> <td>5~7</td> <td>1</td> </tr> <tr> <td>7~9</td> <td>2</td> </tr> </tbody> </table>	Gallery or louver		V m/s	loss mm H ₂ O	3.5~5	0.5	5~7	1	7~9	2	+	<table border="1"> <thead> <tr> <th colspan="2">Register</th> </tr> <tr> <th>V m/s</th> <th>loss mm H₂O</th> </tr> </thead> <tbody> <tr> <td>3.5~5</td> <td>1.5</td> </tr> <tr> <td>5~7</td> <td>3</td> </tr> <tr> <td>7~8</td> <td>6</td> </tr> </tbody> </table>	Register		V m/s	loss mm H ₂ O	3.5~5	1.5	5~7	3	7~8	6	+	<table border="1"> <thead> <tr> <th colspan="2">Hopper</th> </tr> <tr> <th>V m/s</th> <th>loss mm H₂O</th> </tr> </thead> <tbody> <tr> <td>3.5~5</td> <td>0.3</td> </tr> <tr> <td>5~7</td> <td>0.6</td> </tr> <tr> <td>7~9</td> <td>1</td> </tr> </tbody> </table>	Hopper		V m/s	loss mm H ₂ O	3.5~5	0.3	5~7	0.6	7~9	1												
Anemostat																																																													
V m/s	loss mm H ₂ O																																																												
3.5~5	1																																																												
5~7	2																																																												
7~9	3.5																																																												
9~15	6																																																												
Gallery or louver																																																													
V m/s	loss mm H ₂ O																																																												
3.5~5	0.5																																																												
5~7	1																																																												
7~9	2																																																												
Register																																																													
V m/s	loss mm H ₂ O																																																												
3.5~5	1.5																																																												
5~7	3																																																												
7~8	6																																																												
Hopper																																																													
V m/s	loss mm H ₂ O																																																												
3.5~5	0.3																																																												
5~7	0.6																																																												
7~9	1																																																												

Note: W Shows a diameter of round duct or long side length of the rectangular duct.

4. Corresponding Relation Between Rectangular Duct and Round Duct

Circular Duct Diameter, in.	Length of One Side of Rectangular Duct, in.																				
	4	5	6	7	8	9	10	12	14	16	18	20	22	24	26	28	30	32	34	36	
5	5																				
5.5	6	5																			
6	8	6																			
6.5	9	7	6																		
7	11	8	7																		
7.5	13	10	8	7																	
8	15	11	9	8																	
8.5	17	13	10	9																	
9	20	15	12	10	8																
9.5	22	17	13	11	9																
10	25	19	15	12	10	9															
10.5	29	21	16	14	12	10															
11	32	23	18	15	13	11	10														
11.5		26	20	17	14	12	11														
12		29	22	18	15	13	12														
12.5		32	24	20	17	15	13														
13		35	27	22	18	16	14	12													
13.5		38	29	24	20	17	15	13													
14			32	26	22	19	17	14													
14.5			35	28	24	20	18	15													
15			38	30	25	22	19	16	14												
16			45	36	30	25	22	18	15												
17				41	34	29	25	20	17	16											
18				47	39	33	29	23	19	17											
19				54	44	38	33	26	22	19	18										
20					50	43	37	29	24	21	19										
21					57	48	41	33	27	23	20										
22					64	54	46	36	30	26	23	20									
23						60	51	40	33	28	25	22									
24						66	57	44	36	31	27	24	22								
25							63	49	40	34	29	26	24								
26							69	54	44	37	32	28	26	24							
27							76	59	48	40	35	31	28	25							
28								64	52	43	38	33	30	27	26						
29								70	56	47	41	36	32	29	27						
30								76	61	51	44	39	35	31	29	28					
31									82	66	55	47	41	37	34	31	29				
32									89	71	59	51	44	40	36	33	31				
33									96	76	64	54	48	42	38	35	33	30			
34										82	68	58	51	45	41	37	35	32			
35										88	73	62	54	48	44	40	37	34	32		
36										95	78	67	58	51	46	42	39	36	34		
37										101	83	71	62	55	49	45	41	38	36	34	
38										108	89	76	66	58	52	47	44	40	38	36	
39											95	80	70	62	55	50	46	43	40	37	36
40											101	85	74	65	58	53	49	45	42	39	37
41											107	91	78	69	62	56	51	47	44	41	39
42											114	96	83	73	65	59	54	50	46	44	41
43											120	102	88	77	69	62	57	53	49	46	43
44												107	93	81	73	66	60	55	51	48	45
45												113	98	86	76	69	63	58	54	50	47
46												120	103	90	80	72	66	61	56	53	49
47												126	108	95	84	76	69	64	59	55	52
48												133	114	100	89	80	73	67	62	58	54
49												140	120	105	93	84	76	70	65	60	56
50												147	126	110	98	88	80	73	68	63	59
51													132	115	102	92	83	76	71	66	61
52													139	121	107	96	87	80	74	69	64
53													145	127	112	100	91	83	77	71	67
54													152	133	117	105	95	87	80	74	70
55														139	123	110	99	91	84	78	72
56														145	128	114	104	95	87	81	75
57														151	134	119	108	98	91	84	78
58														158	139	124	112	102	94	87	81
59														165	145	130	117	107	98	91	85
60														172	151	135	122	111	102	94	88

5. Method For Duct Calculation (equal friction method)

- 1) Draw schematic view of the duct system.
- 1) Make notes for air volume and mark clearly the elbow, the branch parts, the air discharge outlet.
- 1) Select one main ducting route (where the maximum static pressure loss occurs).
- 1) Select the air velocity for the main duct in accordance with the desirable air velocity.

Main duct	Typical design velocity (m/s)		
	Residence	Public building	Factory
	3.5~6.0	5.0~8.0	6.0~11.0

- 1) Since the velocity and air volume are fixed for main duct, then use the Friction loss chart to find standard friction loss.
- 1) Use air volume and friction loss to find corresponding duct size and velocity for each part of main duct through Frictions loss chart.
- 1) Find the dynamic loss of main ducting route according to the velocity. and type of special fittings (elbows, junctions, regulating flaps, etc.)
- 1) Obtain the duct size and velocity of each branch duct based on the air volume and the same standard friction loss as for the main duct.
- 1) Find the dynamic loss of branch duct.
- 1) Calculate the total pressure loss.

6. Unit Conversion

- 1 inch water=248.8 N/m² (Pa)=0.0361 lb/in² (psi)=25.4 kg/cm²=0.0739 in mercury
- 1 ft³/min (cfm)=1.7 m³/h
- 1 ft/min=5.08*10⁻³ m/s
- 1 inch=2.54 cm=0.0254m=0.08333ft

7. Recommended Outlet Velocity For Different Occasion

The permissible sound level and correspondingly maximum air velocity, is determined by the occasion.

Noise / dB(A)	Occasion	Maximum velocity / m/s
25	Studio, recording room	2
35	Cinema, hospital, library	3
40	Office, school, hotel	4
46	Bank, public hall	5
50	Store, post office	6
70	Factory	10