

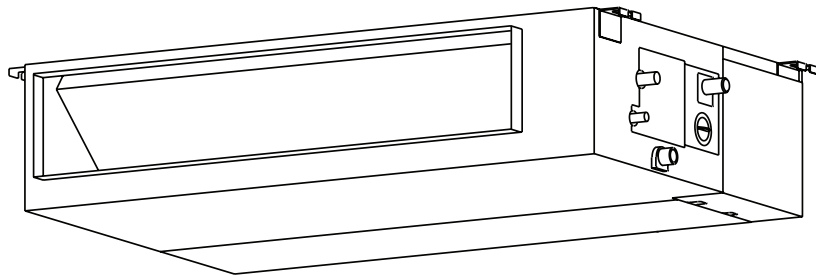

# ENGINEER DATABOOK

## T3 R410A Full DC Inverter Ducted



---

## Table of Contents

Page

<b>1. Specifications .....</b>	<b>4</b>
1. Model Reference	
2. General Specifications	
3. Dimensional Drawings	
4. Electrical Wiring Diagrams	
5. Refrigerant Cycle Diagrams	
6. Capacity Tables	
7. Capacity Correction Factor for Height Difference	
8. Noise Criterion Curves	
9. Electrical Characteristics	
10. Static Pressure	
<b>2. Product Features .....</b>	<b>59</b>
1. Operation Modes and Functions	
2. Remote Controller Functions	

<b>3. Static Pressure Design .....</b>	<b>70</b>
1. Introduction	
2. Charts for Friction Losses in Round Ducts	
3. Dynamic Losses	
4. Corresponding Relation Between Rectangular Duct and Round Duct	
5. Method for Duct Calculation	
6. Unit Conversion	
7. Recommended Outlet Velocity for Different Occasions	

---

# Specifications

## Contents

1.	Model Reference.....	5
2.	General Specifications.....	6
3.	Dimensional Drawings.....	11
4.	Electrical Wiring Diagrams.....	15
5.	Refrigerant Cycle Diagrams.....	26
6.	Capacity Tables.....	29
7.	Capacity Correction Factor for Height Difference.....	42
8.	Noise Criterion Curves.....	47
9.	Electrical Characteristics.....	51
10.	Static Pressure.....	52

## 1. Model Reference

Refer to the following table to determine the specific indoor and outdoor unit model number of your purchased equipment.

Indoor Unit Model	Outdoor Unit Model	Capacity (Btu/h)	Power Supply
42QSM018VSG	38QSM018VSG	18K	1 $\Phi$ , 220-240V~, 50/60Hz
42QSM024VSP	38QSM024VSP	24K	
42QSM030VSP	38QSM030VSP	30K	
42QSM036VSP	38QSM036VSP	36K	
42QSM048VT	38QSM048VT	48K	3 $\Phi$ , 380-415V~, 50/60Hz
42QSM060VT	38QSM060VT	60K	

## 2. General Specifications

Indoor model		42QSM018VSG	42QSM024VSP	42QSM030VSP
Outdoor model		38QSM018VSG	38QSM024VSP	38QSM030VSP
Power supply(indoor)	V-ph-Hz	220-240V~,1Ph, 50/60Hz	220-240V~,1Ph, 50/60Hz	220-240V~,1Ph, 50/60Hz
Power supply(outdoor)	V-ph-Hz	220-240V~,1Ph, 50/60Hz	220-240V~,1Ph, 50/60Hz	220-240V~,1Ph, 50/60Hz
Max. input consumption	W	2600	3200	3700
Max. input current	A	12.9	14.1	16
Indoor fan motor	Model	ZKFN-160-8-1-2	ZKFN-160-8-1-2	ZKFN-160-8-1-2
	Type	DC	DC	DC
	Qty	1	1	1
	Input	W	176	176
	Output	W	160	160
	Speed(Hi/Med/Lo)	r/min	1370/1240/1090	940/870/760
	IP code	IPX0	IPX0	IPX0
Indoor coil	Number of rows	4.0	3	4
	Tube pitch(a)*row pitch(b)	mm	21x13.37	21x13.37
	Fin spacing	mm	1.4	1.4
	FPI		18.1	18.1
	Fin type		Hydrophilic aluminum, golden fin	Hydrophilic aluminum, golden fin
	Tube outside dia. and type	mm	Φ7,inner groove tube	Φ7,innergroove tube
	Coil length*height*width	mm	695x252x53.48	915x294x40.11
	Number of circuits		6	7
Indoor air flow (Hi/Med/Lo) (under rated ESP)	m <sup>3</sup> /h	970/805/630	1365/1100/880	1420/1210/990
ESP	Rated	Pa	25	37
	Range	Pa	0-100	0-160
Indoor noise level (Hi/Med/Lo) (under rated ESP)	dB(A)	43/39/34	40/38/36	43/40.5/38
Indoor unit	Dimension (WxDxH)	mm	880x674x210	1100x774x249
	Packing(WxDxH)	mm	1070x725x280	1305x805x305
	Net/Gross weight	kg	25.8/31	32.6/39.9
Drainage water pipe diameter	mm	ODΦ25mm	ODΦ25	ODΦ25
Controller		Wired control	Wired control	Wired control
Operation temperature	°C	17~30	17~30	17~30
Room temperature	Cooling	°C	17~32	17~32
	Heating	°C	0~30	0~30
Qty/per 20' /40' /40'HQ	Indoor	120/264/297	77/161/184	77/161/184
Compressor	Model	ASN140D35TFZ	ATF235D22TMT	ATF235D22TMT
	Type		ROTARY	ROTARY
	Brand		GMCC	GMCC
	Capacity	Btu/h	14245	24345
	Input	W	1085	1970
	Rated current(RLA)	A	7.6	9.0
	Thermal protector position		INTERNAL	INTERNAL
	Refrigerant oil	ml	VG75-440	RB75EA/670
Outdoor fan motor	Model	ZKFN-80-8-3	ZKFN-120-8-2	ZKFN-120-8-2
	Type	DC	DC	DC
	Qty	1	1	1
	Input	W	88	150
	Output	W	80	120
	Speed	r/min	800/700/550	810/700/450
	Insulation class		E	B
	IP code		IPX4	IPX4
Outdoor coil	Number of rows	2.6	2.6	2.6
	Tube pitch(a)* row pitch(b)	mm	21x13.37	21x13.37
	Fin spacing	mm	1.3	1.3
	FPI		19.5	19.5
	Fin type		Hydrophilic aluminum, golden fin	Hydrophilic aluminum, golden fin
	Tube outside dia. and type	mm	Φ7,inner groove tube	Φ7,innergroove tube
	Coil length * height * width	mm	910*40.11*609	1005x756x26.74+598x756x13.37
	Number of circuits		6	6
Outdoor noise level (sound pressure)	dB(A)	58.5	58	61
Throttle type		EXV+Throttle valve	EXV+Throttle valve	EXV+Throttle valve
Outdoor unit	Dimension(WxDxH)	mm	890x342x673	946x410x810
	Packing(WxDxH)	mm	995x435x750	1090x500x875
	Net/Gross weight	kg	41/44.3	58.6/63.2
Refrigerant type/Quantity	Type		R410A	R410A
	Charged volume	kg	1.60	2.20
Design pressure(Max/Disc./Suc.)	MPa	5.2/4.8/1.5	5.2/4.8/1.5	5.2/4.8/1.5
Refrigerant piping	Liquid side/ Gas side	mm(inch)	Φ6.35/Φ12.7(1/4"/1/2")	Φ9.52/Φ15.9(3/8"/5/8")
	Max. pipe length	m	25	55
	Max. difference in level	m	15	45
Ambient temperature	Cooling	°C	0~55	0~55
	Heating	°C	-15~24	-15~24
Qty/per 20' /40' /40'HQ	Outdoor unit	93/189/189	44/96/138	44/96/138

Remarks:1.The above design and specifications are subject to change without prior notice for product improvement.

---

Notes:

1) Capacities are based on the following conditions:

Cooling(T1): - Indoor Temperature 27°C(80.6°F) DB /19 °C(66.2°F) WB

- Outdoor Temperature 35 °C(95°F) DB /24 °C(75.2°F) WB

- Interconnecting Piping Length 5m

- Level Difference of Zero.

Heating: - Indoor Temperature 20°C(68°F) DB / 15°C(59°F) WB

- Outdoor Temperature 7°C(44.6°F) DB / 6°C(42.8°F) WB

- Interconnecting Piping Length 5 m

- Level Difference of Zero.

Cooling(T3): - Indoor Temperature 29°C(84.2°F) DB /19 °C(66.2°F) WB

- Outdoor Temperature 46 °C(114.8°F) DB /24 °C(75.2°F) WB

- Interconnecting Piping Length 5m

- Level Difference of Zero.

2) Capacities are Net Capacities.

3) Due to our policy of innovation some specifications may be changed without notification.

4) For max. refrigerant pipe length 55m and max. difference in level 45m is based on below installation condition: outdoor unit is on upper side, indoor unit is in bottom side, one oil trap per 10m.

5) City power supply to outdoor unit, indoor power from outdoor side, not allow for separate power supply.

Indoor model		42QSM036VSP	42QSM048VT	42QSM060VT
Outdoor model		38QSM036VSP	38QSM048VT	38QSM060VT
Power supply(indoor)	V-ph-Hz	220-240V~,1Ph, 50/60Hz	220-240V~,1Ph, 50/60Hz	220-240V~,1Ph, 50/60Hz
Power supply(outdoor)	V-ph-Hz	220-240V~,1Ph, 50/60Hz	380-415V, 3N~, 50/60Hz	380-415V, 3N~, 50/60Hz
Max. input consumption	W	4900	6100	6100
Max. input current	A	21.0	14	14
Indoor fan motor	Model	ZKFN-300-8-1	ZKFN-560-8-1-1	ZKFN-560-8-1-1
	Type	DC	DC	DC
	Qty	1	1	1
	Input	W	420	560
	Output	W	300	560
	Speed(Hi/Med/Lo)	r/min	930/840/770	1020/800/600
	IP code	IPX0	IPX0	IPX0
Indoor coil	Number of rows	4	4	4
	Tube pitch(a)*row pitch(b)	mm	21x13.37	25.4x22
	Fin spacing	mm	1.5	1.5
	FPI		16.9	16.9
	Fin type		Hydrophilic aluminum, golden fin	Hydrophilic aluminum, golden fin
	Tube outside dia.and type	mm	Φ7,innergroove tube	Φ9.52,Inner groove tube
	Coil length*height*width	mm	1030x378x53.48	1055x356x88
	Number of circuits		8	7
Indoor air flow (Hi/Med/Lo) (under rated ESP)	m <sup>3</sup> /h	2250/1880/1360	2850/2430/1980	3370/2950/2470
ESP	Rated	Pa	37	50
	Range	Pa	0-160	0-200
Indoor noise level (Hi/Med/Lo) (under rated ESP)	dB(A)	49/46/43	50/47/44	50/47.5/45
Indoor unit	Dimension (WxDxH)	mm	1200x874x300	1400x858x440
	Packing(WxDxH)	mm	1405x915x365	1485x915x460
	Net/Gross weight	kg	44.5/52.7	57/64.7
Drainage water pipe diameter	mm	ODΦ25	ODΦ25mm	ODΦ25mm
Controller		Wired control	Wired control	Wired control
Operation temperature	°C	17~30	17~30	17~30
Room temperature	Cooling	°C	17~32	17~32
	Heating	°C	0~30	0~30
Qty/per 20' /40' /40'HQ	Indoor	62/130/149	59/124/125	35/72/86
Compressor	Model	ATH307CDRC8DUL	ATQ420D1SN5A1	ATQ420D1SN5A1
	Type		ROTARY	ROTARY
	Brand		HIGHLY	GMCC
	Capacity	Btu/h	29377	44220
	Input	W	2660	3485
	Rated current(RLA)	A	9.5	7
	Thermal protector position		INTERNAL	INTERNAL
Refrigerant oil	ml	RMM68EA or equivalent /1050	VG74/1500	
Outdoor fan motor	Model	ZKFN-120-8-2	ZKFN-85-8-22-5	ZKFN-85-8-22-5
	Type	DC	DC	DC
	Qty	1	1+1	1+1
	Input	W	150	126+126
	Output	W	120	85+85
	Speed	r/min	950/850/750	850/650
	Insulation class		B	E
IP code		IPX4	IPX4	
Outdoor coil	Number of rows	3	2.6	3
	Tube pitch(a)* row pitch(b)	mm	21x13.37	21x13.37
	Fin spacing	mm	1.4	1.4
	FPI		18.1	18.1
	Fin type		Hydrophilic aluminum, golden fin	Hydrophilic aluminum, golden fin
	Tube outside dia.and type	mm	Φ7,innergroove tube	Φ7,Inner groove tube
	Coil length * height * width	mm	1000x756x40.11	990x1260x26.74+580x1260x13.37
Number of circuits		6	7	
Outdoor noise level (sound pressure)	dB(A)	63	65	65
Throttle type		EXV+Throttle valve	EXV+Throttle valve	EXV+Throttle valve
Outdoor unit	Dimension(WxDxH)	mm	946x410x810	952x415x1333
	Packing(WxDxH)	mm	1090x500x875	1095x495x1480
	Net/Gross weight	kg	66.0/70.9	107.5/121.5
Refrigerant type/Quantity	Type		R410A	R410A
	Charged volume	kg	3.20	4.20
Design pressure(Max./Disc./Suc.)	MPa	5.2/4.8/1.5	5.2/4.8/1.5	5.2/4.8/1.5
Refrigerant piping	Liquid side/ Gas side	mm(inch)	Φ9.52/Φ19(3/8"/3/4")	9.52mm(3/8in)/19mm(3/4in)
	Max. pipe length	m	30	50
	Max. difference in level	m	20	30
Ambient temperature	Cooling	°C	0~55	0~55
	Heating	°C	-15~24	-15~24
Qty/per 20' /40' /40'HQ	Outdoor unit	44/96/138	22/48/48	22/48/48

Remarks:1.The above design and specifications are subject to change without prior notice for product improvement.

---

Notes:

1) Capacities are based on the following conditions:

Cooling(T1): - Indoor Temperature 27°C(80.6°F) DB /19 °C(66.2°F) WB  
- Outdoor Temperature 35 °C(95°F) DB /24 °C(75.2°F) WB  
- Interconnecting Piping Length 5m  
- Level Difference of Zero.

Heating: - Indoor Temperature 20°C(68°F) DB / 15°C(59°F) WB  
- Outdoor Temperature 7°C(44.6°F) DB / 6°C(42.8°F) WB  
- Interconnecting Piping Length 5 m  
- Level Difference of Zero.

Cooling(T3): - Indoor Temperature 29°C(84.2°F) DB /19 °C(66.2°F) WB  
- Outdoor Temperature 46 °C(114.8°F) DB /24 °C(75.2°F) WB  
- Interconnecting Piping Length 5m  
- Level Difference of Zero.

2) Capacities are Net Capacities.

3) Due to our policy of innovation some specifications may be changed without notification.

4) For max. refrigerant pipe length 55m and max. difference in level 45m is based on below installation condition: outdoor unit is on upper side, indoor unit is in bottom side, one oil trap per 10m.

5) model 42QSM036VSP/38QSM036VSP operated normally in cooling mode at max. piping 55m/vertical 45m, currently can't apply the long piping over 30 meters and can't apply vertical over 20 meters in heating mode.

6) City power supply to outdoor unit, indoor power from outdoor side, not allow for separate power supply.

## Other products information:

1. Compressor Insulation material: Material: PVC + Non spinning fiber.
2. Casing thickness :
  - indoor 18/24/30/36k is 0.6~0.8mm, 0.6mm for top cover, chassis/left panel/right panel is 0.8mm.
  - indoor 48k is 0.8~1.2mm, 0.8mm for top cover/chassis/left panel/right panel, front panel is 1.2mm.
  - indoor 60k is 0.8~1.5mm, 0.8mm for top cover/chassis/left panel/right panel, front panel is 1.5mm.
  - outdoor 18k is 0.6~1.2mm, 0.6mm for front panel/left panel/right panel, top cover is 0.8mm, chassis is 1.2mm.
  - outdoor 24/30/36k is 0.6~1.2mm, 0.6mm for left panel/right panel, front panel/right front panel/top cover is 0.8mm, chassis is 1.2mm.
  - outdoor 48/60k is 0.8~1.5mm, 0.8mm for left panel/right panel/front panel/right front panel/top cover, chassis is 1.5mm.
3. Filter details ( thickness, type, MERV rating):
  - 18/24/30/36k is 10mm thickness aluminum alloy frames with pp net;
  - 48/60k is 5mm thickness iron wire frame with pp net.
  - PS: 18~60k can customize 10mm thickness aluminium alloy frame+aluminium net.
  - Type: nylon; MERV rating: No test data; Filter function: The main function is to prevent large particles of dust into the unit body, prevent dust impact condenser the heat exchange efficiency, and prevent blocking drainage, can purify air.
4. Is supply fan arrangement draw through or blow through?
  - The blower fan is located in front of the cooling coil for 48K and 60K.
  - The cooling coil is located in front of blower fan for 18K, 24K, 30K and 36K.
5. Please advise indoor unit fan material.
  - Fan impeller material: Plastic (ABS), fan casing material: Plastic (HIPS) for 18K,24K, 30K and 36K;
  - Fan impeller material: Metal, fan casing material: Metal for 48K and 60K
6. Outdoor fan blade material
  - AS + glass fiber
7. TEAO – fan motor ( for indoor and outdoor)
  - Indoor motor: normal radiating heat, Outdoor motor: air-cooled

### 3. Dimensional Drawings

#### 3.1 Indoor Unit

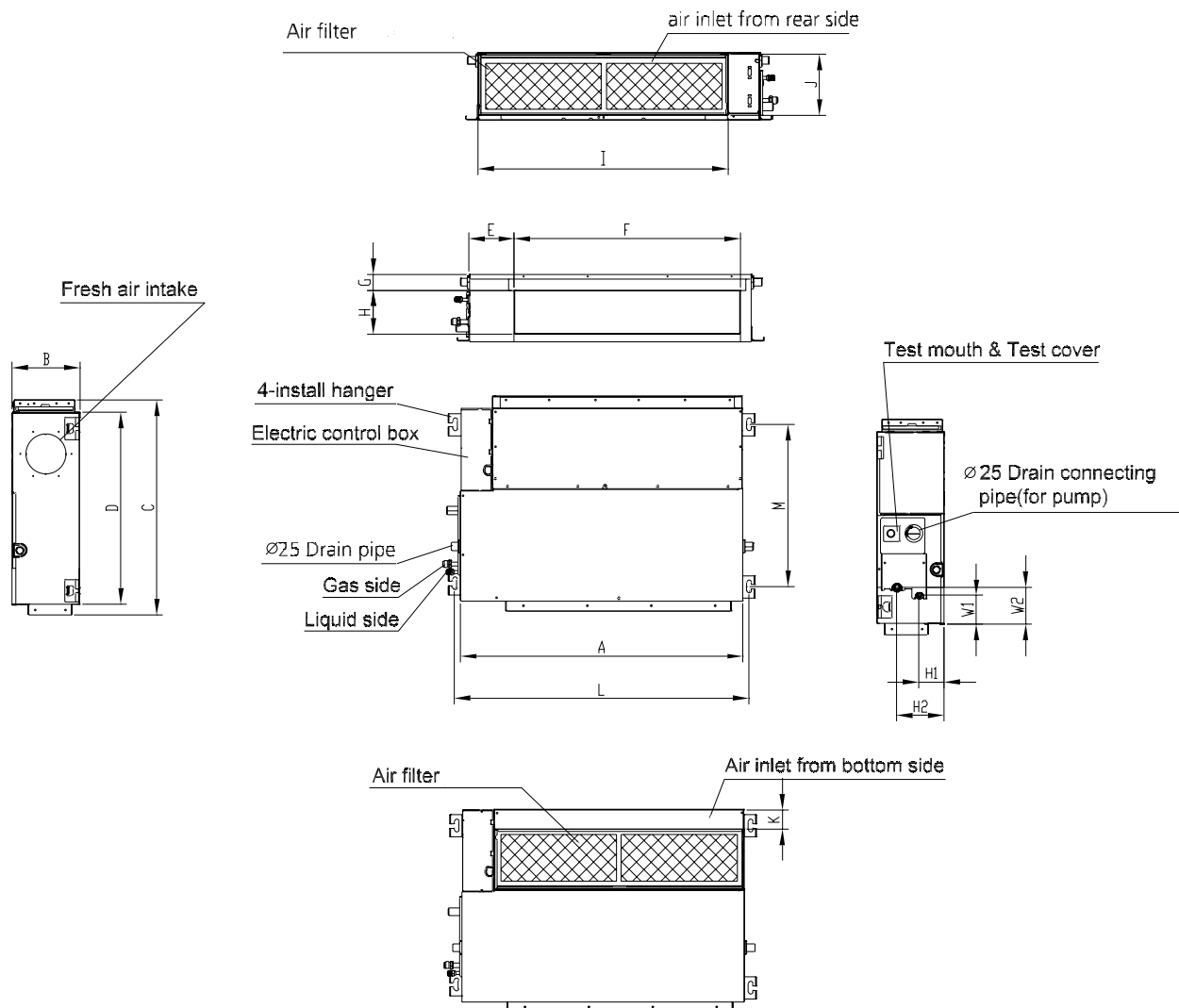

Model	unit	A	B	C	D	E	F	G	H	I	J	K	L	M	H1	H2	W1	W2
18	mm	880	210	674	660	140	706	50	136	782	190	40	920	508	78	148	88	112
	inch	34.65	8.27	26.54	25.98	5.51	27.80	1.97	5.35	30.79	7.48	1.57	36.22	20	3.07	5.83	3.46	4.41
24/30	mm	1100	249	774	700	140	926	50	175	1001	228	5	1140	598	80	150	130	155
	inch	43.31	9.80	30.47	27.56	5.51	36.46	1.97	6.89	39.41	8.98	0.2	44.88	23.54	3.15	5.91	5.12	6.10
36	mm	1200	300	874	800	123	1044	50	227	1101	280	5	1240	697	80	150	185	210
	inch	47.24	11.81	34.41	31.5	4.84	41.1	1.97	8.94	43.35	11.02	0.2	48.82	27.44	3.15	5.91	7.28	8.27

# High Static Pressure Duct

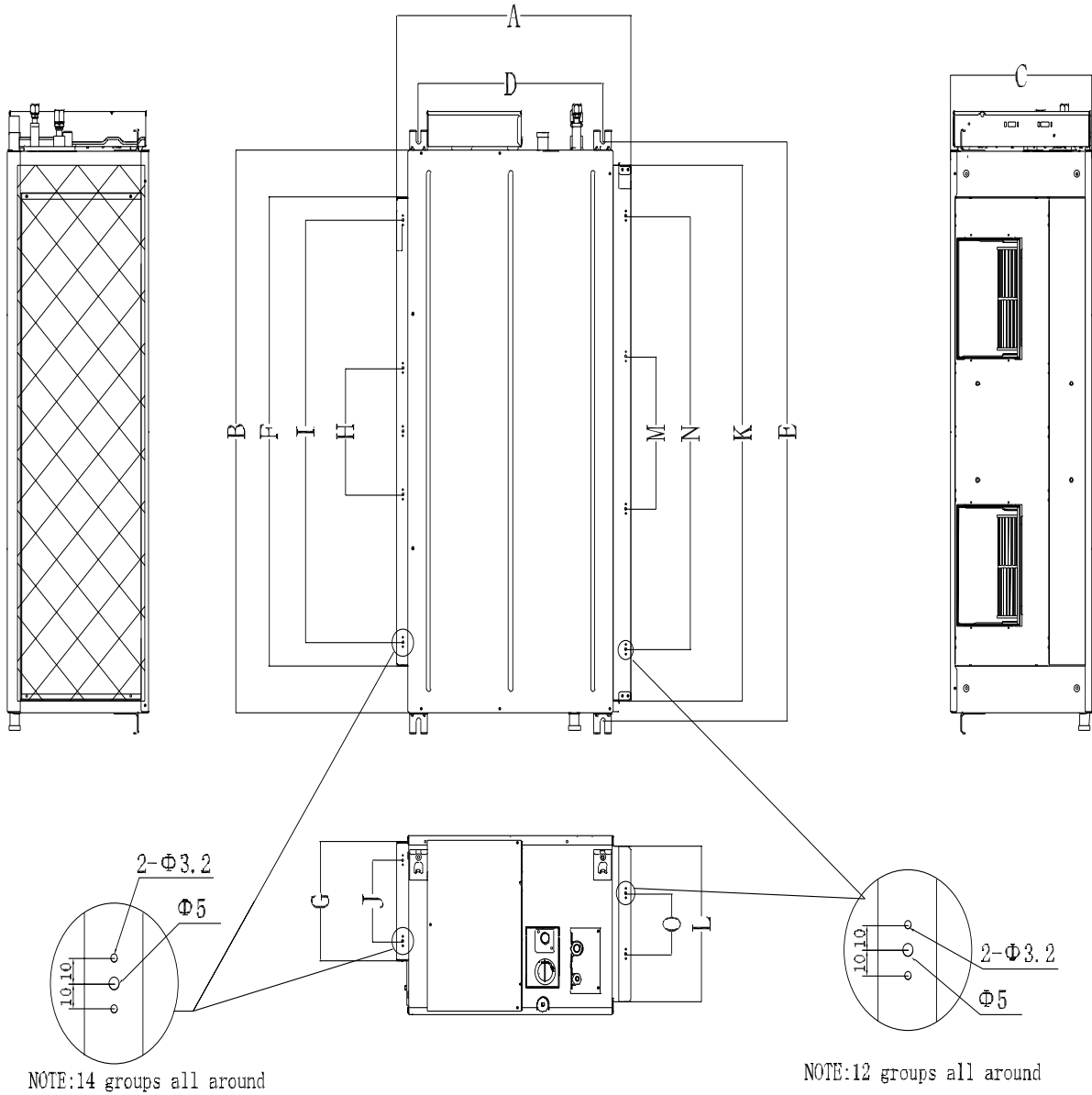

Model (KBtu/h)	unit	Outline dimension			Size of mounted lug		Air outlet opening size(symmetry of air outlet opening)					Air inlet opening size(symmetry of air inlet opening)				
		A	B	C	D	E	F	G	H	I	J	K	L	M	N	O
48	mm	625	1200	380	495	1236	1000	253	270	900	170	1145	334	325	925	130
	inch	24.61	47.24	14.96	19.49	48.66	39.37	9.96	10.63	35.43	6.69	45.08	13.15	12.8	36.42	5.12
60	mm	858	1400	440	700	1436	1188	385	500	1000	280	1188	385	500	1000	280
	inch	33.78	55.12	17.32	27.56	56.54	46.77	15.16	19.69	39.37	11.02	46.77	15.16	19.69	39.37	11.02

## 3.2 Outdoor Unit

### Single Fan Outdoor Unit

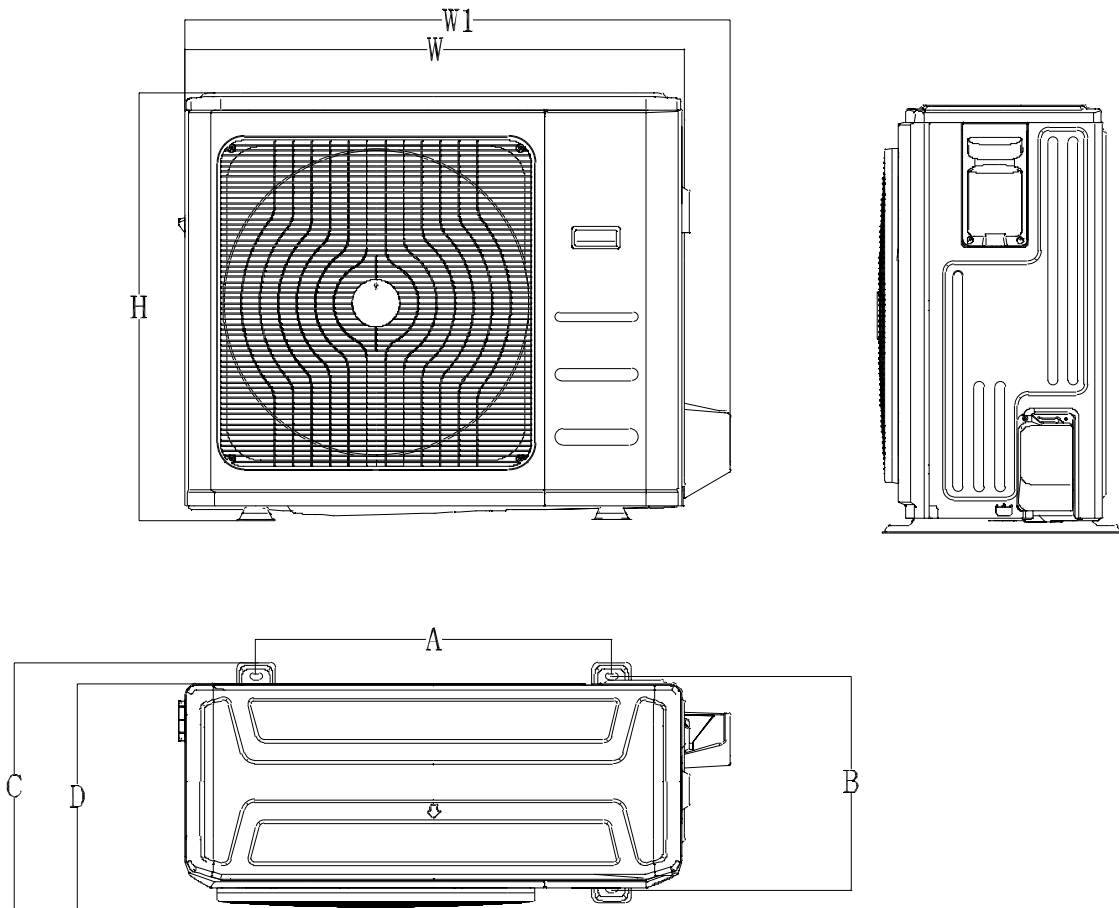

Model	unit	W	D	H	W1	A	B	C
18k	mm	890	342	673	955	663	354	394
	inch	35.04	13.46	26.50	37.60	26.10	13.94	15.51
24/30k	mm	946	410	810	1030	673	403	455
	inch	37.24	16.14	31.89	40.55	26.50	15.87	17.9
36k	mm	946	410	810	1030	673	403	455
	inch	37.24	16.14	31.89	40.55	26.50	15.87	17.9

## Double Fan Outdoor Unit

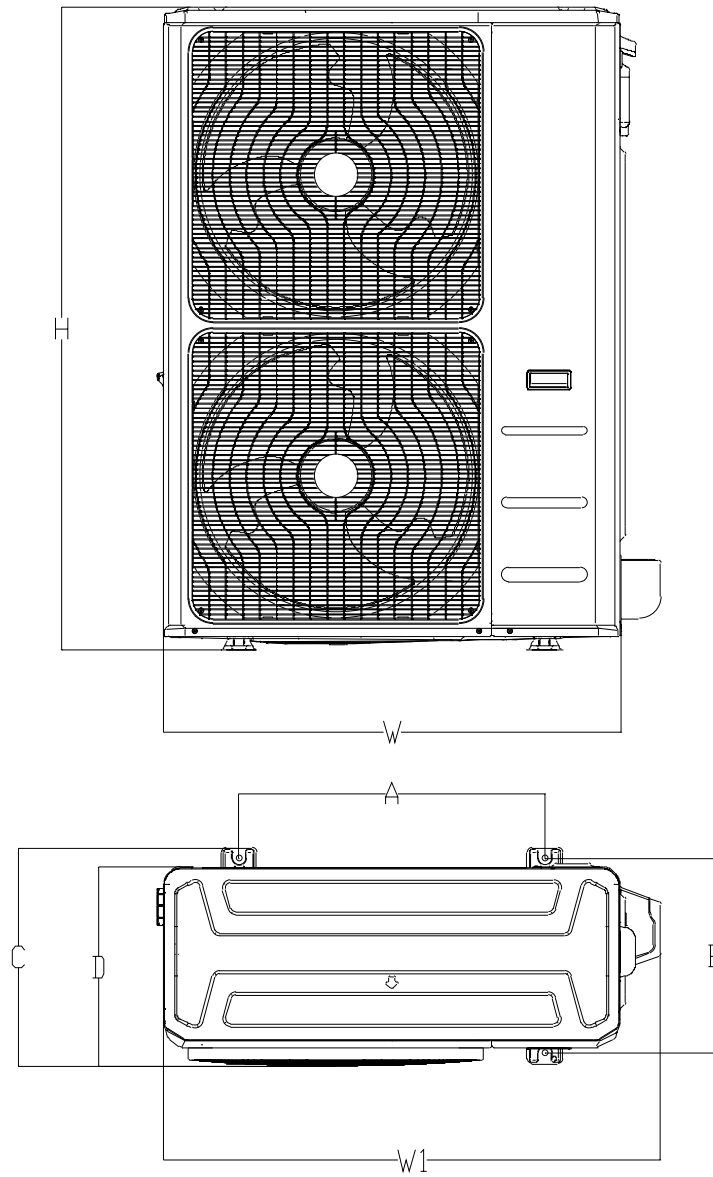

Model	unit	W	D	H	W1	A	B	C
48k	mm	952	415	1333	1045	634	404	457
	inch	37.48	16.34	52.48	41.14	24.96	15.9	17.99
60k	mm	952	415	1333	1045	634	404	457
	inch	37.48	16.34	52.48	41.14	24.96	15.9	17.99

## 4. Electrical Wiring Diagrams

### 4.1 Indoor unit

Abbreviation	Paraphrase
Y/G	Yellow-Green Conductor
CAP1	Indoor Fan Capacitor
FAN1	Indoor Fan
AC FAN	Indoor Alternating Current Fan
PUMP	PUMP
L	LIVE
N	NEUTRAL
TO CCM Comm.Bus	Central Controller
T1	Indoor Room Temperature
T2	Coil Temperature of Indoor Heat Exchanger
P1	Super High Speed
P2	High Speed

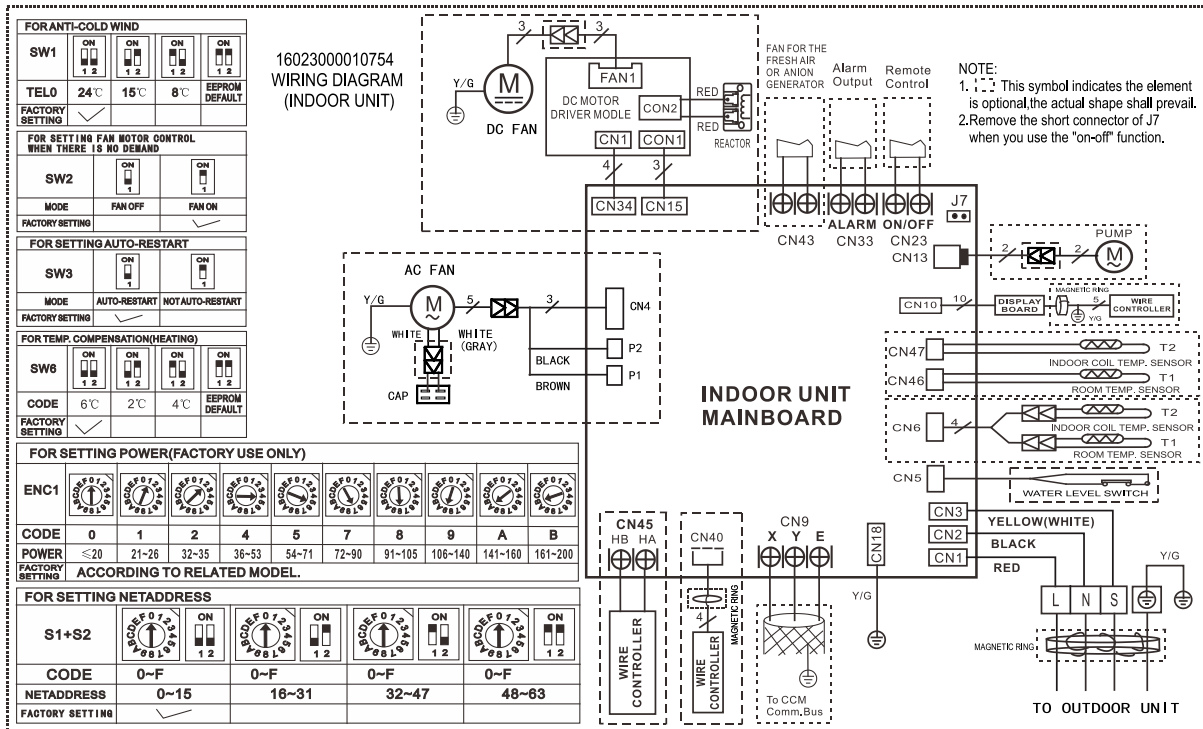
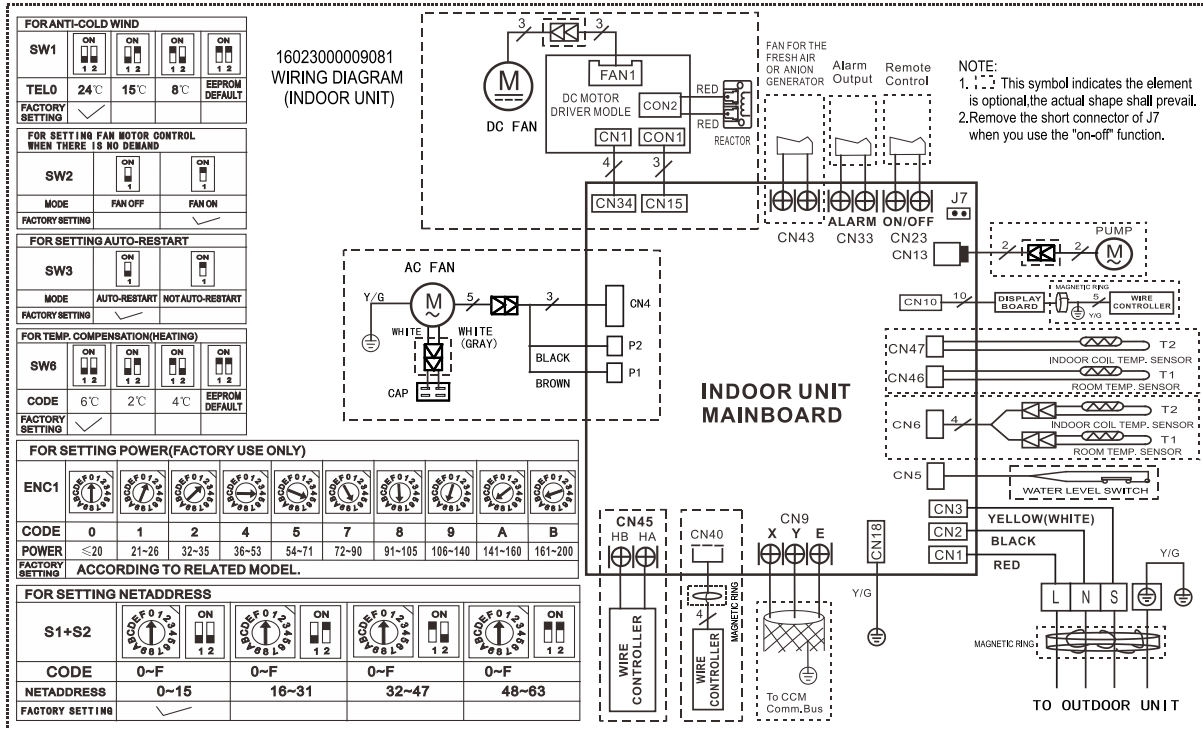

## 4.2 Some connectors introduce:

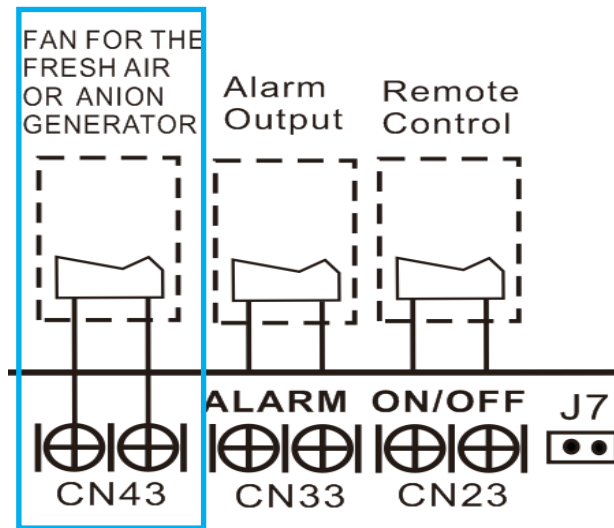

A. For new fresh motor terminal port (also for Anion generator) CN43:

1. Connect the fan motor to the port , no need care L/N of the motor ;
2. The output voltage is the power supply;
3. The fresh motor can not exceed 200W or 1A , follow the smaller one ;
4. The new fresh motor will be worked when the indoor fan motor work ;when the indoor fan motor stops , the new fresh motor would be stopped ;
5. When the unit enter force cooling mode or capacity testing mode , the fresh motor isn't work .

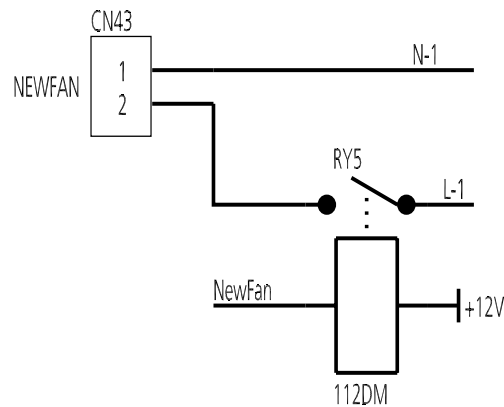

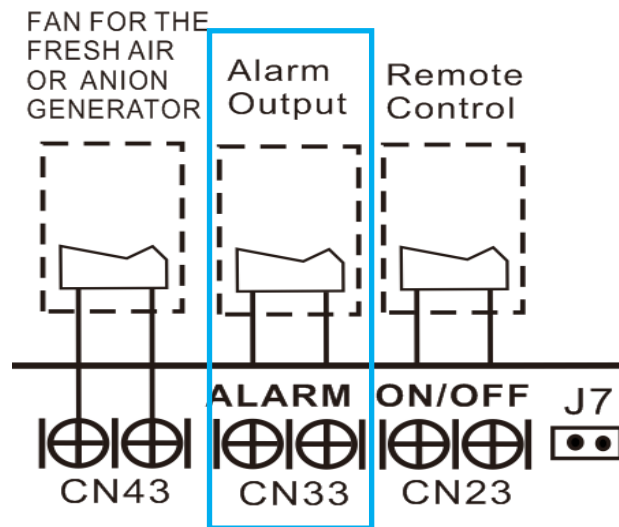

B For ALARM terminal port CN33

1. Provide the terminal port to connect ALARM ,but no voltage of the terminal port , the power from the ALARM system (not from the unit )
2. Although design voltage can support higher voltage ,but we strongly ask you connect the power less than 24V, current less than 0.5A
3. When the unit occurs the problem , the relay would be closed , then ALARM works

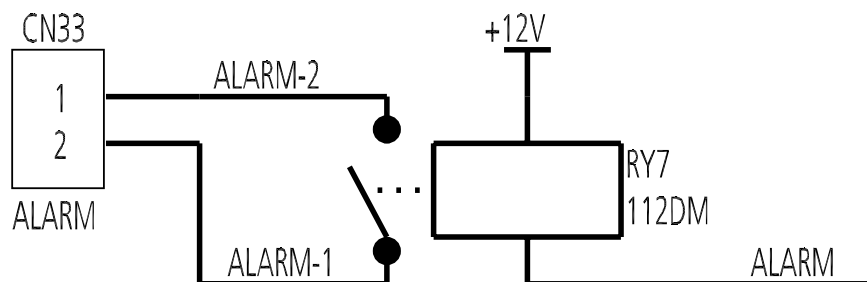

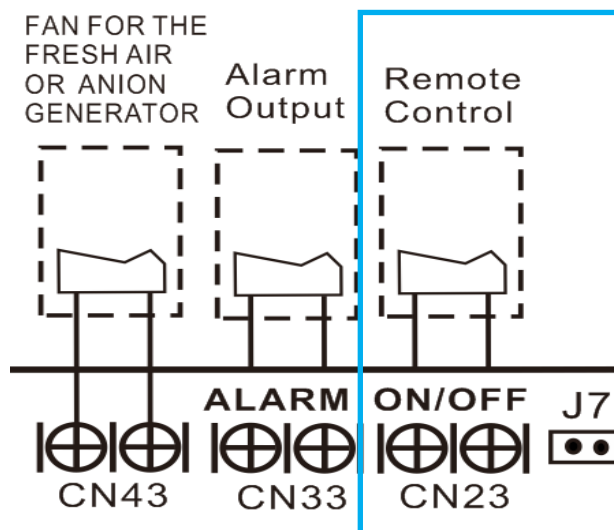

C. For remote control (ON-OFF) terminal port CN23 and short connector of J7

1. Remove the short connector of J7 when you use ON-OFF function;
2. When remote switch off (OPEN) ;the unit would be off;
3. When remote switch on (CLOSE) ;the unit would be on;
4. When close/open the remote switch, the unit would be responded the demand within 2 seconds;
5. When the remote switch on . you can use remote controller/ wire controller to select the mode what you want ;when the remote switch off , the unit would not respond the demand from remote controller/wire controller.

when the remote switch off , but the remote controller / wire controller are on, CP code would be shown on the display board.

6.The voltage of the port is 12V DC, design Max.current is 5mA.

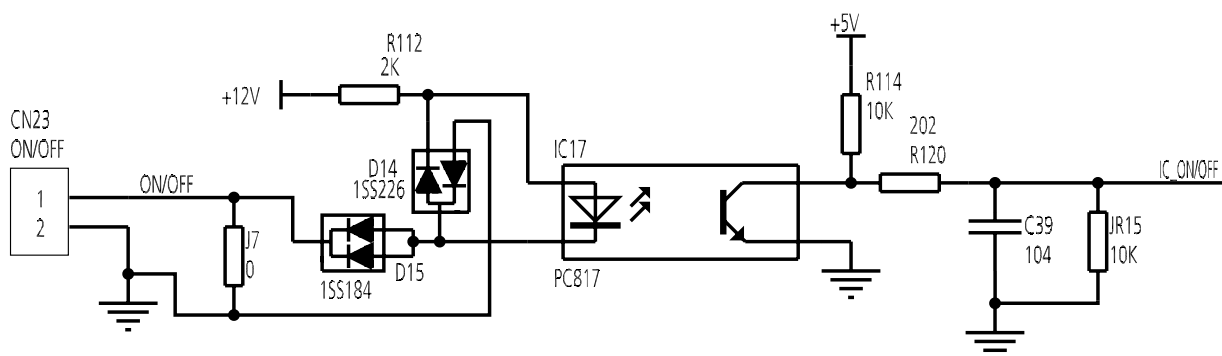

### 4.3 Micro-Switch introduce:



FOR ANTI-COLD WIND				
SW1				
TELO	24°C	15°C	8°C	EEPROM DEFAULT
FACTORY SETTING	✓			

A. Micro-switch SW1 is for selection of indoor fan stop temperature (TELO) when it is in anti-cold wind action in heating mode.

Range: 24°C, 15°C, 8°C, according to EEROM setting (reserved for special customizing).

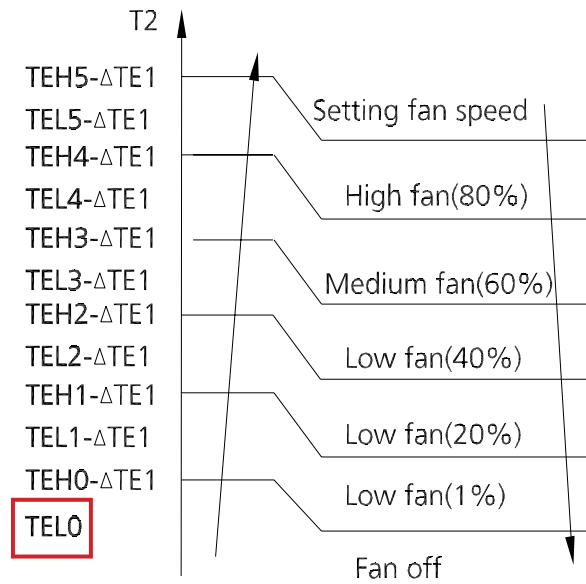

FOR SETTING FAN MOTOR CONTROL WHEN THERE IS NO DEMAND		
SW2		
MODE	FAN OFF	FAN ON
FACTORY SETTING	✓	

B. Micro-switch SW2 is for selection of indoor FAN ACTION if room temperature reaches the set point and the compressor stops.

Range: OFF (in 127s), Keep running.



FOR SETTING AUTO-RESTART		
SW3		
MODE	AUTO-RESTART	NOT AUTO-RESTART
FACTORY SETTING	✓	

C. Micro-switch SW3 is for selection of auto-restart function.

Range: Active, inactive



FOR TEMP. COMPENSATION(HEATING)				
SW6				
CODE	6°C	2°C	4°C	EEPROM DEFAULT
FACTORY SETTING	✓			

D. Micro-switch SW6 is for selection of temperature compensation in heating mode. This helps to reduce the real temperature difference between ceiling and floor so that the unit could run properly. If the height of installation is lower, smaller value could be chosen.

Range: 6°C, 4°C, 2°C, E function (reserved for special customizing)

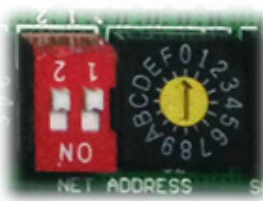

FOR SETTING NETADDRESS				
S1+S2				
CODE	0~F	0~F	0~F	0~F
NETADDRESS	0~15	16~31	32~47	48~63
FACTORY SETTING	✓			

E. Micro-switch S1 and dial-switch S2 are for address setting when you want to control this unit by a central controller.

Range: 00-63



FOR SETTING POWER(DC MOTOR MODEL ONLY)										
ENC1										
CODE	0	1	2	4	5	7	8	9	A	B
POWER	20	26	32-35	36-53	54-71	72-90	91-105	106-140	141-160	161-200
FACTORY SETTING	ACCORDING TO RELATED MODEL.									

F. Dial-switch ENC1: The indoor PCB is universal designed for whole series units from 7K to 68K. This ENC1 setting will tell the main program what size the unit is.

NOTE: Usually there is glue on it because the switch position cannot be changed at random unless you want to use this PCB as a spare part to use in another unit. Then you have to select the right position to match the size of the unit.

“20” means 2kW (7K), “105” means 10.5kW(36K), and so on.

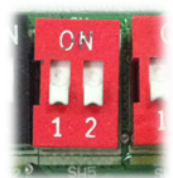

FOR MAIN-SLAVE SETTING				
SW5				
MODE	MAIN NO SLAVE	MAIN	MAIN	SLAVE
FACTORY SETTING	✓			

G. Micro-switch SW5 is for setting the master or slave unit when the unit is in twin connection.

Range: Master no slave (Normal 1 drive 1 connection), Master (2 positions without difference), Slave

## 4.4 Outdoor Unit

<b>Abbreviation</b>	<b>Paraphrase</b>
CAP1, CAP2	Fan Motor Capacitor
COMP	Compressor
FM1, FM2	Outdoor DC Fan
FAN1, FAN2	Outdoor AC Fan
KM8	Contactora
CT1	AC Current Detector
D	Diode Module
EEV	Electronic Expansion Valve
H-PRO	High Pressure Switch
L-PRO	Low Pressure Switch/Shorting Stub
L	PFC Inductor
SV	4-Way Valve
TP	Exhaust Temperature Sensor
T4	Outdoor Ambient Temperature
T3	Coil Temperature of Condenser
TH	Heatsink Temperature Sensor

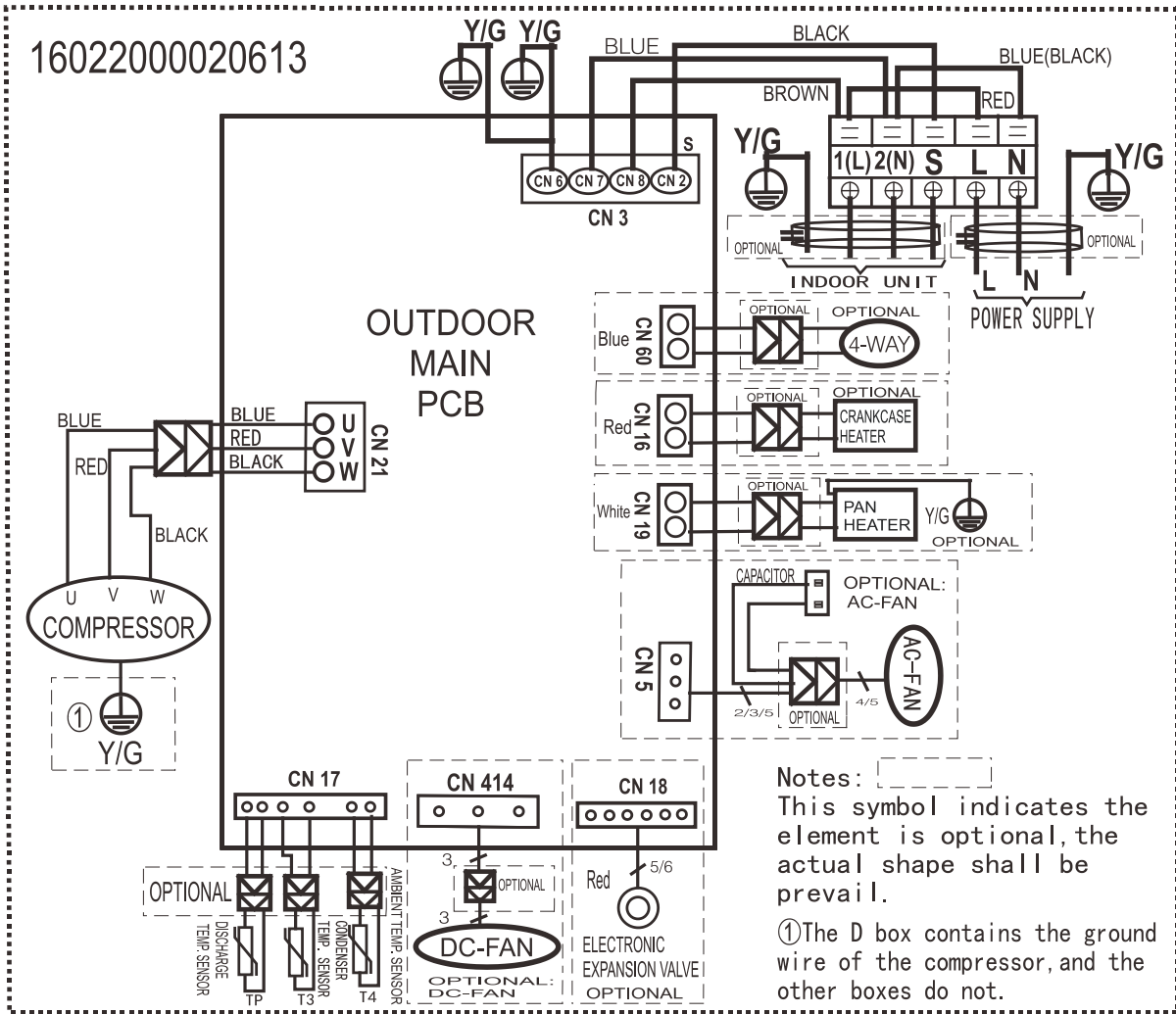

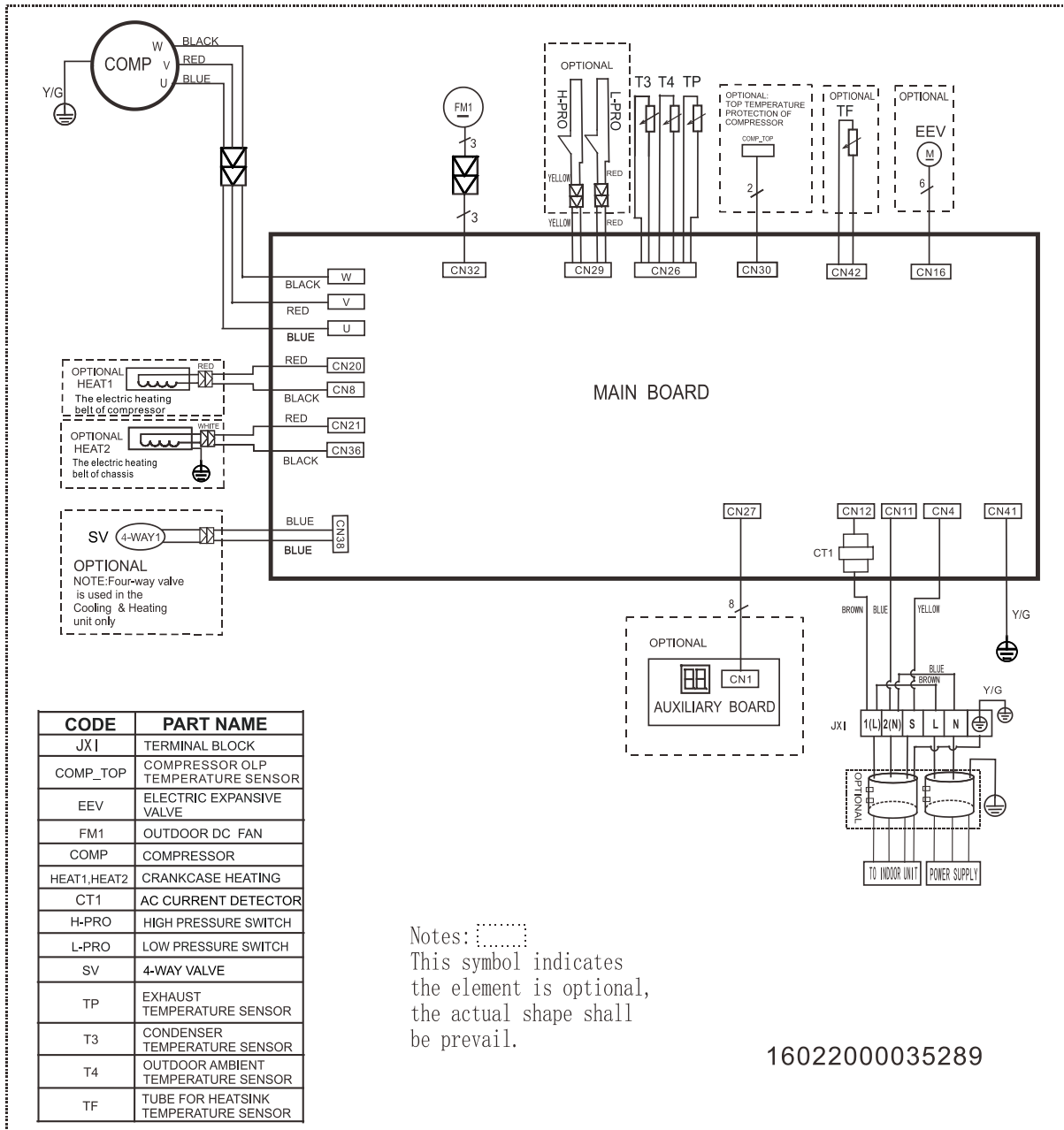

Notes: .....  
 This symbol indicates the element is optional, the actual shape shall be prevail.

16022000035289

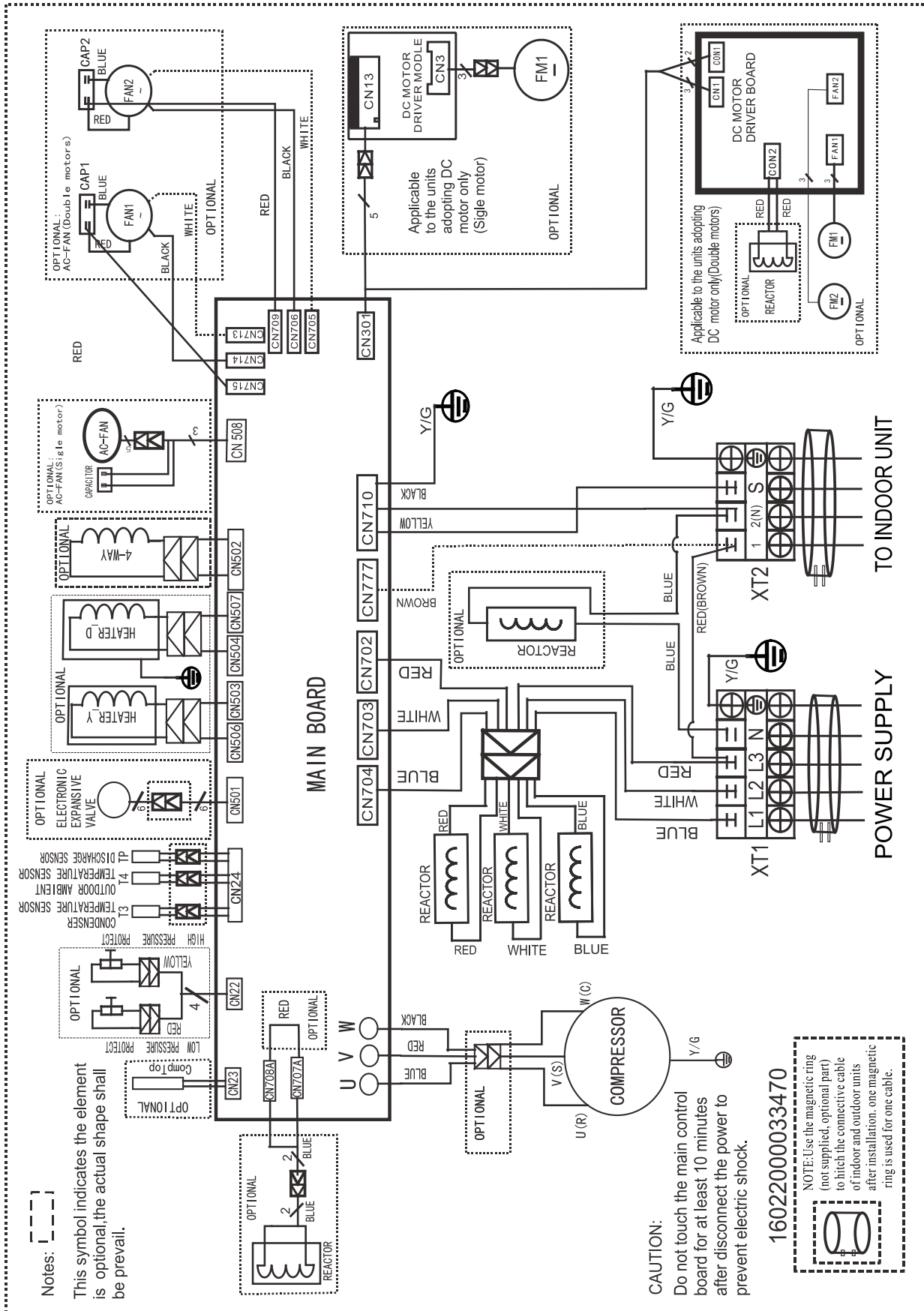

## 5. Refrigerant Cycle Diagrams

### 5.1 Heat pump

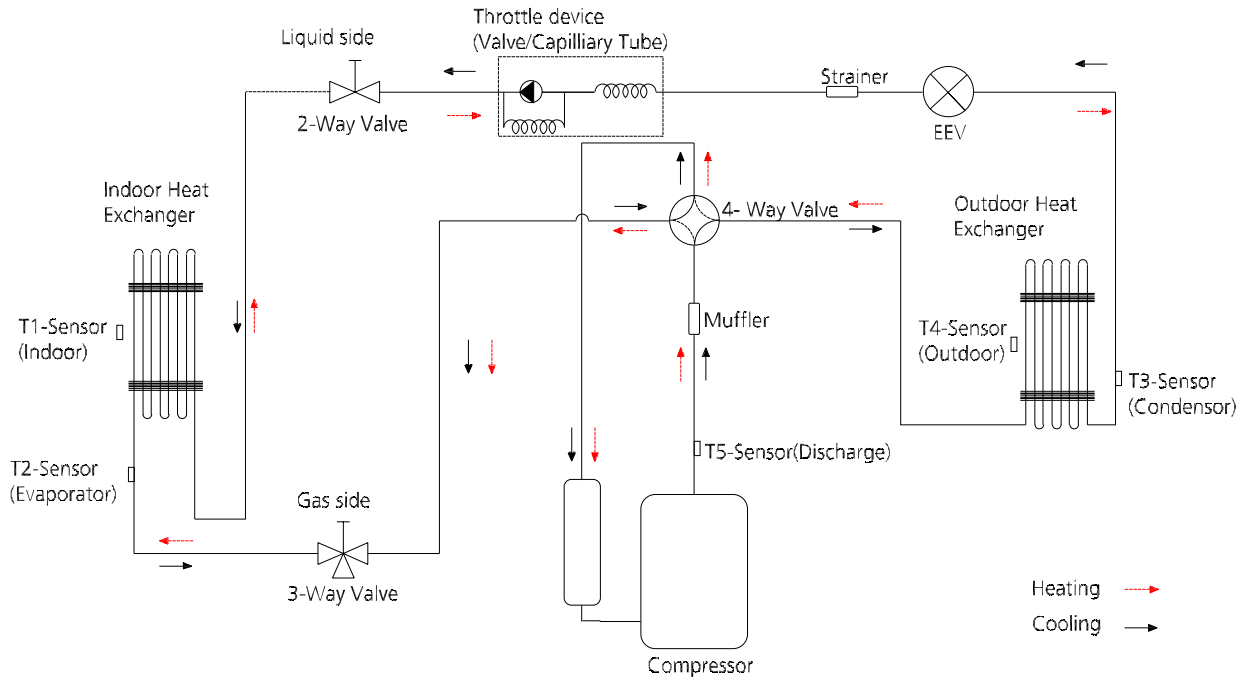

Model(Btu/h)	Pipe Size (Diameter:ø) mm(inch)		Piping length (m/ft)		Elevation (m/ft)		Additional Refrigerant
	Gas	Liquid	Rated	Max.	Rated	Max.	
18k	12.7(1/2)	6.35(1/4)	5/16.4	25/82	0	15/49.2	15g/m (0.16oz/ft)
24k	15.9(5/8)	9.52(3/8)	5/16.4	25/82	0	15/49.2	30g/m (0.32oz/ft)
30k	19(3/4)	9.52(3/8)	5/16.4	30/98.4	0	20/65.6	30g/m (0.32oz/ft)

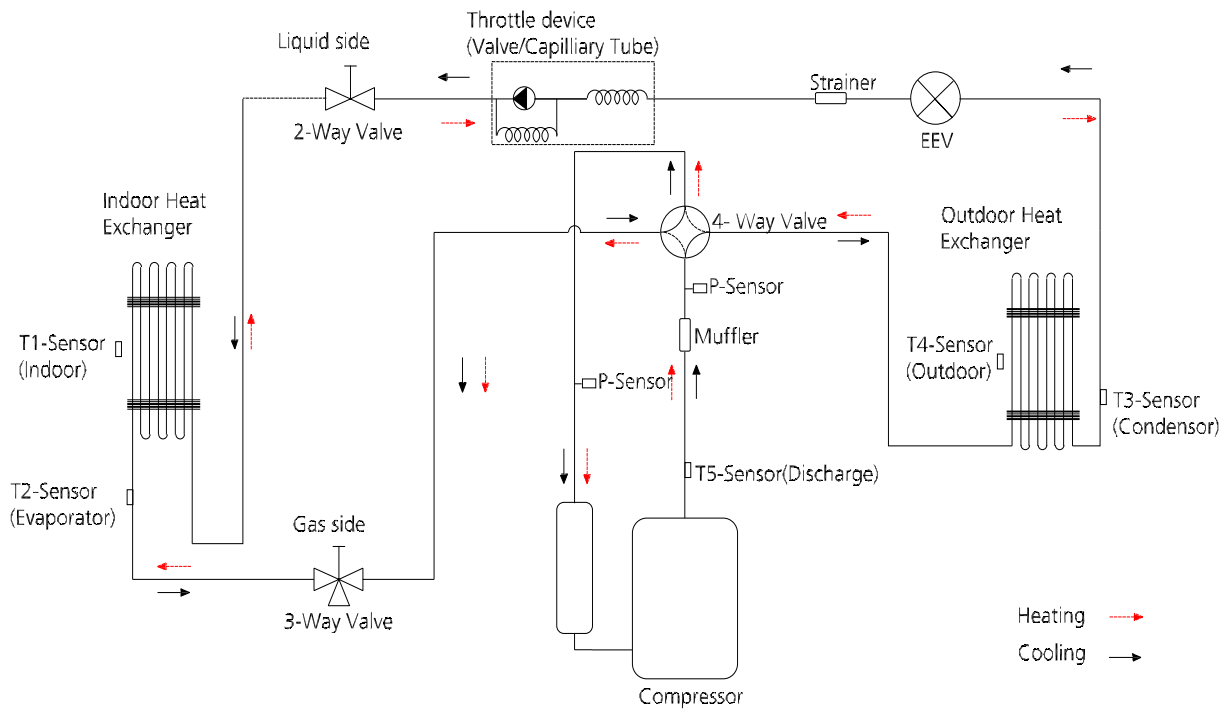

Model No.	Pipe Size (Diameter:ø) mm(inch)		Piping length (m/ft)		Elevation (m/ft)		Additional Refrigerant
	Gas	Liquid	Rated	Max.	Rated	Max.	
36k	19(3/4)	9.52(3/8)	5/16.4	30/98.4	0	20/65.6	30g/m (0.32oz/ft)

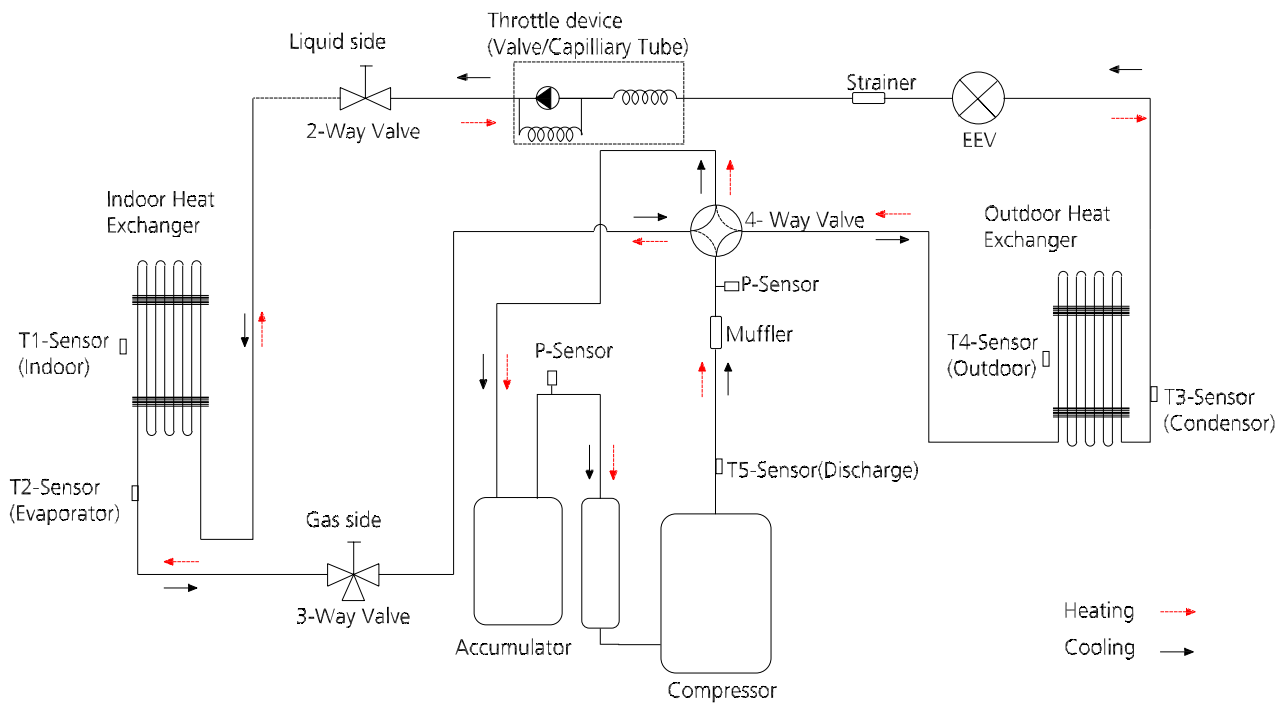

Model No.	Pipe Size (Diameter:ø) mm(inch)		Piping length (m/ft)		Elevation (m/ft)		Additional Refrigerant
	Gas	Liquid	Rated	Max.	Rated	Max.	
48k	19(3/4)	9.52(3/8)	5/16.4	50/164	0	30/98.4	30g/m (0.32oz/ft)
60k	22(7/8)	9.52(3/8)					

# 6. Capacity Tables

## 6.1 Cooling

		38/42QSM018VSG																	
INDOOR AIRFLOW (CFM)	OUTDOOR DB (°C)	ID WB (°C)	17.2				18.0				19.0				22.0				
		ID DB (°C)	24.4	25.0	27.0	29.0	24.4	25.0	27.0	29.0	24.4	25.0	27.0	29.0	24.4	25.0	27.0	29.0	
371	27.0	TC	5.31	5.31	5.31	5.31	5.45	5.45	5.45	5.45	5.62	5.62	5.62	5.62	6.05	6.05	6.05	6.05	
		S/T	0.70	0.72	0.80	0.88	0.63	0.65	0.73	0.81	0.57	0.59	0.66	0.74	0.42	0.44	0.51	0.58	
		PI	1.22	1.22	1.22	1.22	1.22	1.22	1.22	1.22	1.22	1.22	1.22	1.22	1.22	1.22	1.22	1.22	
	30.0	TC	5.13	5.13	5.13	5.19	5.31	5.31	5.31	5.31	5.45	5.45	5.45	5.45	5.88	5.88	5.88	5.88	
		S/T	0.70	0.73	0.81	0.89	0.63	0.66	0.74	0.82	0.57	0.59	0.67	0.75	0.41	0.44	0.51	0.58	
		PI	1.29	1.29	1.29	1.29	1.29	1.29	1.29	1.29	1.29	1.29	1.29	1.29	1.30	1.30	1.30	1.30	
	32.0	TC	5.05	5.05	5.05	5.11	5.19	5.19	5.19	5.19	5.36	5.36	5.36	5.36	5.77	5.77	5.77	5.77	
		S/T	0.71	0.73	0.81	0.89	0.64	0.66	0.74	0.82	0.57	0.59	0.67	0.75	0.41	0.44	0.51	0.58	
		PI	1.34	1.34	1.34	1.34	1.34	1.34	1.34	1.34	1.34	1.34	1.34	1.34	1.35	1.35	1.35	1.35	
	35.0	TC	4.88	4.88	4.88	4.93	5.05	5.05	5.05	5.05	5.19	5.19	5.28	5.19	5.59	5.59	5.59	5.59	
		S/T	0.71	0.74	0.83	0.91	0.64	0.67	0.75	0.83	0.57	0.60	0.67	0.76	0.41	0.44	0.51	0.59	
		PI	1.41	1.41	1.41	1.41	1.41	1.41	1.41	1.41	1.42	1.42	1.42	1.42	1.43	1.43	1.43	1.43	
	43.0	TC	4.45	4.45	4.45	4.49	4.60	4.60	4.60	4.60	4.75	4.75	4.77	4.75	5.13	5.13	5.13	5.13	
		S/T	0.73	0.76	0.86	0.95	0.65	0.68	0.77	0.87	0.58	0.61	0.70	0.79	0.41	0.44	0.52	0.60	
		PI	1.66	1.66	1.66	1.66	1.66	1.66	1.66	1.66	1.67	1.67	1.67	1.67	1.68	1.68	1.68	1.68	
	46.0	TC	4.31	4.31	4.31	4.34	4.46	4.46	4.46	4.46	4.60	4.60	4.60	4.60	4.98	4.98	4.98	4.98	
		S/T	0.74	0.77	0.87	0.97	0.66	0.69	0.79	0.88	0.59	0.61	0.71	0.80	0.41	0.44	0.52	0.61	
		PI	1.75	1.75	1.75	1.75	1.76	1.76	1.76	1.76	1.76	1.76	1.76	1.76	1.77	1.77	1.77	1.77	
	52.0	TC	3.84	3.84	3.86	3.89	3.95	3.95	3.95	3.98	4.09	4.09	4.09	4.09	4.43	4.43	4.43	4.43	
		S/T	0.77	0.80	0.91	1.00	0.68	0.71	0.82	0.92	0.60	0.63	0.73	0.83	0.41	0.44	0.53	0.63	
		PI	1.96	1.96	1.96	1.96	1.96	1.96	1.96	1.96	1.97	1.97	1.97	1.97	1.98	1.98	1.98	1.98	
	474	27.0	TC	5.42	5.42	5.42	5.48	5.57	5.57	5.57	5.62	5.74	5.74	5.74	5.74	6.17	6.17	6.17	6.17
			S/T	0.74	0.77	0.87	0.97	0.66	0.69	0.79	0.88	0.59	0.62	0.71	0.80	0.41	0.44	0.52	0.61
			PI	1.24	1.24	1.24	1.24	1.24	1.24	1.24	1.24	1.24	1.24	1.24	1.24	1.25	1.25	1.25	1.25
30.0		TC	5.25	5.25	5.31	5.37	5.42	5.42	5.42	5.48	5.60	5.60	5.60	5.60	6.03	6.03	6.03	6.03	
		S/T	0.75	0.78	0.88	0.98	0.67	0.70	0.80	0.89	0.59	0.62	0.72	0.81	0.41	0.44	0.53	0.62	
		PI	1.32	1.32	1.32	1.32	1.32	1.32	1.32	1.32	1.32	1.32	1.32	1.32	1.32	1.32	1.32	1.32	
32.0		TC	5.17	5.17	5.22	5.28	5.31	5.31	5.31	5.37	5.48	5.48	5.48	5.48	5.91	5.91	5.91	5.91	
		S/T	0.76	0.79	0.89	0.99	0.67	0.70	0.81	0.90	0.59	0.62	0.72	0.82	0.41	0.44	0.53	0.62	
		PI	1.36	1.36	1.36	1.36	1.37	1.37	1.37	1.37	1.37	1.37	1.37	1.37	1.38	1.38	1.38	1.38	
35.0		TC	4.99	4.99	5.05	5.11	5.17	5.17	5.17	5.22	5.31	5.31	5.31	5.31	5.74	5.74	5.74	5.74	
		S/T	0.77	0.80	0.90	1.00	0.68	0.71	0.81	0.91	0.60	0.63	0.73	0.83	0.41	0.44	0.53	0.63	
		PI	1.44	1.44	1.44	1.44	1.44	1.44	1.44	1.44	1.45	1.45	1.45	1.45	1.45	1.45	1.45	1.45	
43.0		TC	4.58	4.58	4.64	4.69	4.73	4.73	4.73	4.79	4.88	4.88	4.90	4.92	5.27	5.27	5.27	5.27	
		S/T	0.79	0.83	0.94	1.00	0.70	0.73	0.85	0.96	0.61	0.65	0.76	0.87	0.41	0.44	0.54	0.65	
		PI	1.70	1.70	1.70	1.70	1.70	1.70	1.70	1.70	1.71	1.71	1.71	1.71	1.72	1.72	1.72	1.72	
46.0		TC	4.43	4.43	4.49	4.54	4.57	4.57	4.57	4.63	4.72	4.72	4.72	4.78	5.10	5.10	5.10	5.10	
		S/T	0.81	0.84	0.96	1.00	0.71	0.75	0.87	0.98	0.62	0.65	0.77	0.88	0.41	0.44	0.55	0.66	
		PI	1.80	1.80	1.80	1.80	1.80	1.80	1.80	1.80	1.81	1.81	1.81	1.81	1.82	1.82	1.82	1.82	
52.0		TC	3.95	3.95	3.98	4.01	4.06	4.06	4.09	4.12	4.21	4.21	4.21	4.23	4.58	4.58	4.58	4.58	
		S/T	0.84	0.88	1.00	1.00	0.74	0.78	0.91	1.00	0.64	0.68	0.81	0.93	0.41	0.45	0.57	0.91	
		PI	2.01	2.01	2.01	2.01	2.01	2.01	2.01	2.01	2.02	2.02	2.02	2.02	2.03	2.03	2.03	2.03	
571		27.0	TC	5.54	5.54	5.60	5.65	5.68	5.68	5.68	5.74	5.85	5.85	5.85	5.85	6.31	6.31	6.31	6.31
			S/T	0.79	0.83	0.94	1.00	0.70	0.73	0.85	0.96	0.61	0.65	0.76	0.87	0.41	0.44	0.55	0.65
			PI	1.27	1.27	1.27	1.27	1.27	1.27	1.27	1.27	1.27	1.27	1.27	1.27	1.27	1.27	1.27	1.27
	30.0	TC	5.37	5.37	5.42	5.48	5.54	5.54	5.54	5.60	5.71	5.71	5.71	5.71	6.14	6.14	6.14	6.14	
		S/T	0.80	0.84	0.95	1.00	0.71	0.74	0.86	0.97	0.62	0.65	0.76	0.88	0.41	0.44	0.55	0.66	
		PI	1.34	1.34	1.34	1.34	1.34	1.34	1.34	1.34	1.35	1.35	1.35	1.35	1.35	1.35	1.35	1.35	
	32.0	TC	5.25	5.25	5.31	5.37	5.42	5.42	5.42	5.48	5.60	5.60	5.60	5.65	6.03	6.03	6.03	6.03	
		S/T	0.81	0.84	0.96	1.00	0.71	0.75	0.87	0.98	0.62	0.65	0.77	0.88	0.41	0.44	0.55	0.66	
		PI	1.39	1.39	1.39	1.39	1.39	1.39	1.39	1.39	1.40	1.40	1.40	1.40	1.40	1.40	1.40	1.40	
	35.0	TC	5.11	5.11	5.17	5.22	5.25	5.25	5.25	5.31	5.42	5.42	5.51	5.57	5.85	5.85	5.85	5.85	
		S/T	0.82	0.86	0.98	1.00	0.72	0.76	0.88	1.00	0.63	0.66	0.78	0.89	0.41	0.45	0.56	0.67	
		PI	1.47	1.47	1.47	1.47	1.47	1.47	1.47	1.47	1.48	1.48	1.48	1.48	1.49	1.49	1.49	1.49	
	43.0	TC	4.67	4.72	4.77	4.83	4.82	4.82	4.86	4.92	4.99	4.99	5.02	5.07	5.38	5.38	5.38	5.38	
		S/T	0.85	0.89	1.00	1.00	0.75	0.79	0.92	1.00	0.65	0.69	0.82	0.94	0.41	0.45	0.57	0.90	
		PI	1.73	1.73	1.73	1.73	1.74	1.74	1.74	1.74	1.74	1.74	1.74	1.74	1.76	1.76	1.76	1.76	
	46.0	TC	4.52	4.57	4.63	4.69	4.66	4.66	4.72	4.78	4.84	4.84	4.84	4.89	5.21	5.21	5.21	5.21	
		S/T	0.87	0.91	1.00	1.00	0.76	0.80	0.94	1.00	0.65	0.69	0.83	0.96	0.42	0.45	0.58	0.92	
		PI	1.83	1.83	1.83	1.83	1.84	1.84	1.84	1.84	1.84	1.84	1.84	1.84	1.86	1.86	1.86	1.86	
	52.0	TC	4.03	4.06	4.09	4.12	4.18	4.18	4.21	4.23	4.29	4.29	4.29	4.35	4.66	4.66	4.66	4.66	
		S/T	0.91	0.96	1.00	1.00	0.79	0.84	0.99	1.00	0.68	0.72	0.87	1.00	0.42	0.46	0.60	0.97	
		PI	2.05	2.05	2.05	2.05	2.05	2.05	2.05	2.05	2.06	2.06	2.06	2.06	2.08	2.08	2.08	2.08	

TC: Total Cooling Capacity (kW)  
 S/T: Sensible Cooling Capacity Ratio  
 PI: Power Input (kW)

Note: The table shows the case where the operation frequency of a compressor is fixed.

Specifications

38/42QSM024VSP																		
INDOOR AIRFLOW (CFM)	OUTDOOR DB (°C)	ID WB (°C)	17.2				18.0				19.0				22.0			
		ID DB (°C)	24.4	25.0	27.0	29.0	24.4	25.0	27.0	29.0	24.4	25.0	27.0	29.0	24.4	25.0	27.0	29.0
518	27.0	TC	7.15	7.15	7.15	7.21	7.35	7.35	7.35	7.35	7.58	7.58	7.58	7.58	8.16	8.16	8.16	8.16
		S/T	0.70	0.73	0.81	0.89	0.63	0.66	0.74	0.82	0.57	0.59	0.67	0.75	0.41	0.44	0.51	0.58
		PI	1.61	1.61	1.61	1.61	1.61	1.61	1.61	1.61	1.61	1.61	1.61	1.61	1.62	1.62	1.62	1.62
	30.0	TC	6.95	6.95	6.95	7.01	7.15	7.15	7.15	7.15	7.38	7.38	7.38	7.38	7.96	7.96	7.96	7.96
		S/T	0.71	0.73	0.82	0.90	0.64	0.66	0.75	0.83	0.57	0.59	0.67	0.75	0.41	0.44	0.51	0.58
		PI	1.70	1.70	1.70	1.70	1.70	1.70	1.70	1.70	1.70	1.70	1.70	1.70	1.71	1.71	1.71	1.71
	32.0	TC	6.81	6.81	6.81	6.87	7.01	7.01	7.01	7.01	7.24	7.24	7.24	7.24	7.79	7.79	7.79	7.79
		S/T	0.71	0.74	0.83	0.91	0.64	0.67	0.75	0.83	0.57	0.60	0.68	0.76	0.41	0.44	0.51	0.59
		PI	1.76	1.76	1.76	1.76	1.76	1.76	1.76	1.76	1.77	1.77	1.77	1.77	1.77	1.77	1.77	1.77
	35.0	TC	6.61	6.61	6.61	6.67	6.81	6.81	6.81	6.81	7.01	7.01	7.12	7.01	7.56	7.56	7.56	7.56
		S/T	0.72	0.75	0.84	0.92	0.65	0.67	0.76	0.84	0.58	0.60	0.68	0.77	0.41	0.44	0.51	0.59
		PI	1.86	1.86	1.86	1.86	1.86	1.86	1.86	1.86	1.87	1.87	1.87	1.87	1.88	1.88	1.88	1.88
	43.0	TC	6.03	6.03	6.03	6.09	6.21	6.21	6.21	6.25	6.41	6.41	6.45	6.41	6.92	6.92	6.92	6.92
		S/T	0.74	0.77	0.87	0.96	0.66	0.69	0.78	0.88	0.59	0.61	0.70	0.80	0.41	0.44	0.52	0.61
		PI	2.18	2.18	2.18	2.18	2.19	2.19	2.19	2.19	2.19	2.19	2.19	2.19	2.21	2.21	2.21	2.21
	46.0	TC	5.83	5.83	5.83	5.89	6.01	6.01	6.01	6.07	6.21	6.21	6.21	6.21	6.71	6.71	6.71	6.71
		S/T	0.75	0.78	0.88	0.98	0.67	0.70	0.80	0.89	0.59	0.62	0.72	0.81	0.41	0.44	0.53	0.62
		PI	2.30	2.30	2.30	2.30	2.31	2.31	2.31	2.31	2.31	2.31	2.31	2.31	2.33	2.33	2.33	2.33
52.0	TC	5.19	5.19	5.25	5.30	5.36	5.36	5.36	5.42	5.53	5.53	5.53	5.53	6.02	6.02	6.02	6.02	
	S/T	0.78	0.81	0.92	1.00	0.69	0.72	0.83	0.94	0.60	0.64	0.74	0.85	0.41	0.44	0.54	0.63	
	PI	2.57	2.57	2.57	2.57	2.58	2.58	2.58	2.58	2.58	2.58	2.58	2.58	2.60	2.60	2.60	2.60	
647	27.0	TC	7.30	7.30	7.30	7.39	7.50	7.50	7.50	7.59	7.73	7.73	7.73	7.73	8.33	8.33	8.33	8.33
		S/T	0.75	0.78	0.88	0.98	0.67	0.70	0.80	0.89	0.59	0.62	0.71	0.81	0.41	0.44	0.53	0.61
		PI	1.65	1.65	1.65	1.65	1.65	1.65	1.65	1.65	1.65	1.65	1.65	1.65	1.65	1.65	1.65	1.65
	30.0	TC	7.07	7.07	7.13	7.19	7.30	7.30	7.30	7.39	7.53	7.53	7.53	7.53	8.10	8.10	8.10	8.10
		S/T	0.76	0.79	0.89	0.99	0.67	0.70	0.80	0.90	0.59	0.62	0.72	0.82	0.41	0.44	0.53	0.62
		PI	1.73	1.73	1.73	1.73	1.73	1.73	1.73	1.73	1.74	1.74	1.74	1.74	1.74	1.74	1.74	1.74
	32.0	TC	6.96	6.96	7.01	7.07	7.16	7.16	7.16	7.21	7.39	7.39	7.39	7.39	7.96	7.96	7.96	7.96
		S/T	0.76	0.79	0.90	1.00	0.68	0.71	0.81	0.91	0.60	0.63	0.73	0.83	0.41	0.44	0.53	0.62
		PI	1.80	1.80	1.80	1.80	1.80	1.80	1.80	1.80	1.80	1.80	1.80	1.80	1.81	1.81	1.81	1.81
	35.0	TC	6.73	6.73	6.78	6.84	6.96	6.96	6.96	7.01	7.16	7.16	7.27	7.16	7.73	7.73	7.73	7.73
		S/T	0.77	0.80	0.91	1.00	0.68	0.71	0.82	0.92	0.60	0.63	0.73	0.84	0.41	0.44	0.53	0.63
		PI	1.90	1.90	1.90	1.90	1.90	1.90	1.90	1.90	1.91	1.91	1.91	1.91	1.91	1.91	1.91	1.91
	43.0	TC	6.21	6.21	6.26	6.32	6.40	6.40	6.40	6.46	6.60	6.60	6.63	6.64	7.14	7.14	7.14	7.14
		S/T	0.80	0.84	0.95	1.00	0.70	0.74	0.86	0.97	0.62	0.65	0.76	0.88	0.41	0.44	0.55	0.65
		PI	2.23	2.23	2.23	2.23	2.24	2.24	2.24	2.24	2.24	2.24	2.24	2.24	2.25	2.25	2.25	2.25
	46.0	TC	6.01	6.01	6.07	6.13	6.18	6.18	6.18	6.24	6.39	6.39	6.39	6.45	6.92	6.92	6.92	6.92
		S/T	0.81	0.85	0.97	1.00	0.72	0.75	0.87	0.99	0.62	0.66	0.78	0.89	0.41	0.44	0.55	0.66
		PI	2.35	2.35	2.35	2.35	2.36	2.36	2.36	2.36	2.36	2.36	2.36	2.36	2.38	2.38	2.38	2.38
52.0	TC	5.33	5.38	5.44	5.50	5.53	5.53	5.58	5.64	5.70	5.70	5.70	5.76	6.19	6.19	6.19	6.19	
	S/T	0.85	0.89	1.00	1.00	0.74	0.78	0.91	1.00	0.64	0.68	0.81	0.94	0.41	0.45	0.57	0.91	
	PI	2.63	2.63	2.63	2.63	2.63	2.63	2.63	2.63	2.64	2.64	2.64	2.66	2.66	2.66	2.66	2.66	
803	27.0	TC	7.44	7.44	7.53	7.62	7.67	7.67	7.67	7.76	7.90	7.90	7.90	7.99	8.51	8.51	8.51	8.51
		S/T	0.81	0.84	0.96	1.00	0.71	0.75	0.87	0.98	0.62	0.65	0.77	0.88	0.41	0.44	0.55	0.66
		PI	1.68	1.68	1.68	1.68	1.68	1.68	1.68	1.68	1.68	1.68	1.68	1.68	1.69	1.69	1.69	1.69
	30.0	TC	7.21	7.21	7.30	7.39	7.44	7.44	7.44	7.53	7.67	7.67	7.67	7.76	8.28	8.28	8.28	8.28
		S/T	0.82	0.85	0.98	1.00	0.72	0.76	0.88	1.00	0.63	0.66	0.78	0.90	0.41	0.45	0.56	0.67
		PI	1.77	1.77	1.77	1.77	1.77	1.77	1.77	1.77	1.77	1.77	1.77	1.77	1.78	1.78	1.78	1.78
	32.0	TC	7.07	7.07	7.13	7.19	7.30	7.30	7.39	7.47	7.53	7.53	7.53	7.62	8.10	8.10	8.10	8.10
		S/T	0.82	0.86	0.99	1.00	0.72	0.76	0.88	1.00	0.63	0.67	0.79	0.90	0.41	0.45	0.56	0.67
		PI	1.84	1.84	1.84	1.84	1.84	1.84	1.84	1.84	1.84	1.84	1.84	1.84	1.85	1.85	1.85	1.85
	35.0	TC	6.87	6.87	6.93	6.98	7.07	7.07	7.13	7.19	7.30	7.30	7.42	7.50	7.87	7.87	7.87	7.87
		S/T	0.83	0.87	1.00	1.00	0.73	0.77	0.90	1.00	0.64	0.67	0.79	0.91	0.41	0.45	0.56	0.68
		PI	1.94	1.94	1.94	1.94	1.94	1.94	1.94	1.94	1.95	1.95	1.95	1.95	1.96	1.96	1.96	1.96
	43.0	TC	6.33	6.37	6.43	6.49	6.51	6.51	6.57	6.63	6.73	6.73	6.76	6.82	7.29	7.29	7.29	7.29
		S/T	0.87	0.91	1.00	1.00	0.76	0.80	0.94	1.00	0.65	0.70	0.83	0.97	0.42	0.45	0.58	0.90
		PI	2.27	2.27	2.27	2.27	2.28	2.28	2.28	2.28	2.28	2.28	2.28	2.28	2.30	2.30	2.30	2.30
	46.0	TC	6.13	6.18	6.24	6.30	6.30	6.30	6.36	6.42	6.51	6.51	6.51	6.57	7.06	7.06	7.06	7.06
		S/T	0.89	0.93	1.00	1.00	0.77	0.82	0.96	1.00	0.67	0.71	0.85	0.99	0.42	0.46	0.59	0.92
		PI	2.40	2.40	2.40	2.40	2.41	2.41	2.41	2.41	2.41	2.41	2.41	2.41	2.43	2.43	2.43	2.43
52.0	TC	5.44	5.50	5.56	5.61	5.64	5.64	5.70	5.76	5.81	5.81	5.87	5.93	6.30	6.30	6.30	6.30	
	S/T	0.93	0.98	1.00	1.00	0.81	0.86	1.00	1.00	0.69	0.74	0.89	1.00	0.42	0.46	0.61	0.97	
	PI	2.68	2.68	2.68	2.68	2.69	2.69	2.69	2.69	2.69	2.69	2.69	2.69	2.72	2.72	2.72	2.72	

TC:Total Cooling Capacity (kW)

S/T:Sensible Cooling Capacity Ratio

PI:Power Input(kW)

Note: The table shows the case where the operation frequency of a compressor is fixed.

38/42QSM030VSP

INDOOR AIRFLOW (CFM)	OUTDOOR DB (°C)	ID WB (°C)	17.2				18.0				19.0				22.0				
		ID DB (°C)	24.4	25.0	27.0	29.0	24.4	25.0	27.0	29.0	24.4	25.0	27.0	29.0	24.4	25.0	27.0	29.0	
		TC	S/T	PI	TC	S/T	PI	TC	S/T	PI	TC	S/T	PI	TC	S/T	PI	TC	S/T	PI
582	27.0	TC	8.47	8.47	8.47	8.47	8.73	8.73	8.73	8.73	8.99	8.99	8.99	8.99	9.68	9.68	9.68	9.68	
		S/T	0.70	0.72	0.80	0.88	0.63	0.65	0.73	0.80	0.56	0.59	0.66	0.73	0.42	0.44	0.51	0.57	
		PI	2.07	2.07	2.07	2.07	2.07	2.07	2.07	2.07	2.07	2.07	2.07	2.07	2.07	2.07	2.07	2.07	2.07
	30.0	TC	8.21	8.21	8.21	8.30	8.47	8.47	8.47	8.47	8.73	8.73	8.73	8.73	9.42	9.42	9.42	9.42	
		S/T	0.70	0.72	0.81	0.88	0.63	0.66	0.73	0.81	0.57	0.59	0.66	0.74	0.42	0.44	0.51	0.58	
		PI	2.19	2.19	2.19	2.19	2.19	2.19	2.19	2.19	2.19	2.19	2.19	2.19	2.20	2.20	2.20	2.20	
	32.0	TC	8.07	8.07	8.07	8.16	8.33	8.33	8.33	8.33	8.56	8.56	8.56	8.56	9.25	9.25	9.25	9.25	
		S/T	0.70	0.73	0.81	0.89	0.63	0.66	0.74	0.82	0.57	0.59	0.67	0.75	0.41	0.44	0.51	0.58	
		PI	2.26	2.26	2.26	2.26	2.26	2.26	2.26	2.26	2.27	2.27	2.27	2.27	2.28	2.28	2.28	2.28	
	35.0	TC	7.81	7.81	7.81	7.90	8.07	8.07	8.07	8.07	8.33	8.33	8.44	8.33	8.96	8.96	8.96	8.96	
		S/T	0.71	0.73	0.82	0.90	0.64	0.66	0.74	0.83	0.57	0.59	0.67	0.75	0.41	0.44	0.51	0.58	
		PI	2.39	2.39	2.39	2.39	2.39	2.39	2.39	2.39	2.40	2.40	2.40	2.40	2.41	2.41	2.41	2.41	
	43.0	TC	6.72	6.72	6.72	6.78	6.94	6.94	6.94	6.94	7.15	7.15	7.18	7.15	7.72	7.72	7.72	7.72	
		S/T	0.73	0.76	0.85	0.94	0.65	0.68	0.77	0.86	0.58	0.61	0.69	0.78	0.41	0.44	0.52	0.60	
		PI	2.50	2.50	2.50	2.50	2.51	2.51	2.51	2.51	2.51	2.51	2.51	2.51	2.53	2.53	2.53	2.53	
	46.0	TC	6.31	6.31	6.31	6.37	6.53	6.53	6.53	6.53	6.71	6.71	6.71	6.71	7.27	7.27	7.27	7.27	
		S/T	0.74	0.77	0.86	0.96	0.66	0.69	0.78	0.87	0.58	0.61	0.70	0.79	0.41	0.44	0.52	0.61	
		PI	2.54	2.54	2.54	2.54	2.55	2.55	2.55	2.55	2.56	2.56	2.56	2.56	2.57	2.57	2.57	2.57	
	52.0	TC	6.16	6.16	6.21	6.27	6.38	6.38	6.38	6.44	6.58	6.58	6.58	6.58	7.16	7.16	7.16	7.16	
		S/T	0.76	0.80	0.90	1.00	0.68	0.71	0.81	0.91	0.60	0.63	0.73	0.83	0.41	0.44	0.53	0.62	
		PI	3.31	3.31	3.31	3.31	3.31	3.31	3.31	3.31	3.32	3.32	3.32	3.32	3.35	3.35	3.35	3.35	
	712	27.0	TC	8.65	8.65	8.65	8.74	8.91	8.91	8.91	8.91	9.17	9.17	9.17	9.17	9.88	9.88	9.88	9.88
			S/T	0.73	0.76	0.85	0.94	0.65	0.68	0.77	0.86	0.58	0.61	0.70	0.78	0.41	0.44	0.52	0.60
			PI	2.11	2.11	2.11	2.11	2.11	2.11	2.11	2.11	2.11	2.11	2.11	2.11	2.12	2.12	2.12	2.12
30.0		TC	8.39	8.39	8.39	8.48	8.65	8.65	8.65	8.65	8.91	8.91	8.91	8.91	9.63	9.63	9.63	9.63	
		S/T	0.74	0.77	0.86	0.96	0.66	0.69	0.78	0.87	0.58	0.61	0.70	0.79	0.41	0.44	0.52	0.61	
		PI	2.23	2.23	2.23	2.23	2.23	2.23	2.23	2.23	2.24	2.24	2.24	2.24	2.25	2.25	2.25	2.25	
32.0		TC	8.25	8.25	8.25	8.33	8.48	8.48	8.48	8.48	8.76	8.76	8.76	8.76	9.42	9.42	9.42	9.42	
		S/T	0.74	0.77	0.87	0.96	0.66	0.69	0.79	0.88	0.59	0.61	0.71	0.80	0.41	0.44	0.52	0.61	
		PI	2.31	2.31	2.31	2.31	2.31	2.31	2.31	2.31	2.31	2.31	2.31	2.31	2.33	2.33	2.33	2.33	
35.0		TC	7.99	7.99	7.99	8.07	8.25	8.25	8.25	8.33	8.48	8.48	8.62	8.48	9.17	9.17	9.17	9.17	
		S/T	0.75	0.78	0.88	0.98	0.67	0.70	0.80	0.89	0.59	0.62	0.71	0.81	0.41	0.44	0.53	0.61	
		PI	2.44	2.44	2.44	2.44	2.44	2.44	2.44	2.44	2.45	2.45	2.45	2.45	2.45	2.45	2.45	2.45	
43.0		TC	6.81	6.81	6.85	6.91	7.03	7.03	7.03	7.12	7.25	7.25	7.29	7.25	7.84	7.84	7.84	7.84	
		S/T	0.78	0.81	0.92	1.00	0.69	0.72	0.83	0.93	0.60	0.63	0.74	0.84	0.41	0.44	0.54	0.63	
		PI	2.55	2.55	2.55	2.55	2.56	2.56	2.56	2.56	2.57	2.57	2.57	2.57	2.58	2.58	2.58	2.58	
46.0		TC	6.40	6.40	6.45	6.51	6.61	6.61	6.61	6.69	6.82	6.82	6.82	6.82	7.38	7.38	7.38	7.38	
		S/T	0.79	0.82	0.93	1.00	0.70	0.73	0.84	0.95	0.61	0.64	0.75	0.86	0.41	0.44	0.54	0.64	
		PI	2.59	2.59	2.59	2.59	2.60	2.60	2.60	2.60	2.61	2.61	2.61	2.61	2.63	2.63	2.63	2.63	
52.0		TC	6.25	6.25	6.31	6.37	6.45	6.45	6.45	6.51	6.68	6.68	6.68	6.74	7.25	7.25	7.25	7.25	
		S/T	0.82	0.86	0.98	1.00	0.72	0.76	0.88	1.00	0.63	0.66	0.78	0.90	0.41	0.45	0.56	0.91	
		PI	3.37	3.37	3.37	3.37	3.38	3.38	3.38	3.38	3.39	3.39	3.39	3.39	3.42	3.42	3.42	3.42	
835		27.0	TC	8.82	8.82	8.91	8.99	9.08	9.08	9.08	9.17	9.37	9.37	9.37	9.37	10.09	10.09	10.09	10.09
			S/T	0.77	0.80	0.90	1.00	0.68	0.71	0.82	0.92	0.60	0.63	0.73	0.83	0.41	0.44	0.53	0.63
			PI	2.15	2.15	2.15	2.15	2.15	2.15	2.15	2.15	2.15	2.16	2.16	2.16	2.16	2.16	2.16	2.16
	30.0	TC	8.56	8.56	8.65	8.74	8.82	8.82	8.82	8.91	9.11	9.11	9.11	9.11	9.80	9.80	9.80	9.80	
		S/T	0.77	0.81	0.91	1.00	0.69	0.72	0.83	0.93	0.60	0.63	0.74	0.84	0.41	0.44	0.54	0.63	
		PI	2.27	2.27	2.27	2.27	2.27	2.27	2.27	2.27	2.27	2.27	2.27	2.27	2.28	2.28	2.28	2.28	
	32.0	TC	8.39	8.39	8.48	8.56	8.65	8.65	8.65	8.74	8.94	8.94	8.94	8.94	9.63	9.63	9.63	9.63	
		S/T	0.78	0.81	0.92	1.00	0.69	0.72	0.83	0.94	0.61	0.64	0.74	0.85	0.41	0.44	0.54	0.64	
		PI	2.35	2.35	2.35	2.35	2.36	2.36	2.36	2.36	2.36	2.36	2.36	2.36	2.37	2.37	2.37	2.37	
	35.0	TC	8.13	8.13	8.22	8.30	8.39	8.39	8.39	8.48	8.65	8.65	8.79	8.65	9.34	9.34	9.34	9.34	
		S/T	0.79	0.82	0.94	1.00	0.70	0.73	0.85	0.95	0.61	0.64	0.75	0.86	0.41	0.44	0.54	0.65	
		PI	2.49	2.49	2.49	2.49	2.49	2.49	2.49	2.49	2.50	2.50	2.50	2.50	2.51	2.51	2.51	2.51	
	43.0	TC	6.93	6.93	6.99	7.05	7.17	7.17	7.23	7.31	7.39	7.39	7.43	7.45	8.00	8.00	8.00	8.00	
		S/T	0.82	0.86	0.98	1.00	0.72	0.76	0.88	1.00	0.63	0.66	0.78	0.90	0.41	0.45	0.56	0.90	
		PI	2.60	2.60	2.60	2.60	2.61	2.61	2.61	2.61	2.62	2.62	2.62	2.62	2.64	2.64	2.64	2.64	
	46.0	TC	6.51	6.51	6.56	6.61	6.74	6.74	6.82	6.90	6.95	6.95	6.95	7.03	7.53	7.53	7.53	7.53	
		S/T	0.84	0.88	1.00	1.00	0.73	0.77	0.90	1.00	0.64	0.67	0.80	0.92	0.41	0.45	0.56	0.92	
		PI	2.64	2.64	2.64	2.64	2.65	2.65	2.65	2.65	2.66	2.66	2.66	2.66	2.69	2.69	2.69	2.69	
	52.0	TC	6.37	6.43	6.48	6.54	6.60	6.60	6.65	6.71	6.82	6.82	6.82	6.88	7.39	7.39	7.39	7.39	
		S/T	0.88	0.92	1.00	1.00	0.76	0.81	0.94	1.00	0.66	0.70	0.84	0.97	0.42	0.45	0.58	0.97	
		PI	3.44	3.44	3.44	3.44	3.45	3.45	3.45	3.45	3.46	3.46	3.46	3.46	3.49	3.49	3.49	3.49	

TC: Total Capacity(kW)  
 S/T: Sensible Capacity ratio  
 PI: Power Input(kW)

Specifications

		38/42QSM036VSP																
INDOOR AIRFLOW (CFM)	OUTDOOR DB (°C)	ID WB (°C)	17.2				18.0				19.0				22.0			
		ID DB (°C)	24.4	25.0	27.0	29.0	24.4	25.0	27.0	29.0	24.4	25.0	27.0	29.0	24.4	25.0	27.0	29.0
800	27.0	TC	9.82	9.82	9.82	9.91	10.11	10.11	10.11	10.11	10.42	10.42	10.42	10.42	11.23	11.23	11.23	11.23
		S/T	0.73	0.76	0.85	0.94	0.65	0.68	0.77	0.86	0.58	0.61	0.69	0.78	0.41	0.44	0.52	0.60
		PI	2.31	2.31	2.31	2.31	2.31	2.31	2.31	2.31	2.31	2.31	2.31	2.31	2.32	2.32	2.32	2.32
	30.0	TC	9.53	9.53	9.53	9.62	9.82	9.82	9.82	9.82	10.14	10.14	10.14	10.14	10.91	10.91	10.91	10.91
		S/T	0.73	0.76	0.86	0.95	0.66	0.68	0.78	0.87	0.58	0.61	0.70	0.79	0.41	0.44	0.52	0.60
		PI	2.44	2.44	2.44	2.44	2.44	2.44	2.44	2.44	2.45	2.45	2.45	2.45	2.46	2.46	2.46	2.46
	32.0	TC	9.36	9.36	9.36	9.45	9.65	9.65	9.65	9.65	9.94	9.94	9.94	9.94	10.71	10.71	10.71	10.71
		S/T	0.74	0.77	0.87	0.96	0.66	0.69	0.78	0.88	0.58	0.61	0.70	0.80	0.41	0.44	0.52	0.61
		PI	2.52	2.52	2.52	2.52	2.53	2.53	2.53	2.53	2.53	2.53	2.53	2.53	2.54	2.54	2.54	2.54
	35.0	TC	9.08	9.08	9.08	9.16	9.36	9.36	9.36	9.45	9.65	9.65	9.79	9.65	10.40	10.40	10.40	10.40
		S/T	0.75	0.78	0.88	0.97	0.67	0.69	0.79	0.89	0.59	0.62	0.71	0.81	0.41	0.44	0.52	0.61
		PI	2.67	2.67	2.67	2.67	2.67	2.67	2.67	2.67	2.68	2.68	2.68	2.68	2.69	2.69	2.69	2.69
	43.0	TC	8.37	8.37	8.43	8.52	8.64	8.64	8.64	8.72	8.91	8.91	8.95	8.91	9.62	9.62	9.62	9.62
		S/T	0.77	0.81	0.91	1.00	0.68	0.72	0.82	0.93	0.60	0.63	0.74	0.84	0.41	0.44	0.54	0.63
		PI	3.14	3.14	3.14	3.14	3.14	3.14	3.14	3.14	3.15	3.15	3.15	3.15	3.18	3.18	3.18	3.18
	46.0	TC	8.13	8.13	8.22	8.31	8.40	8.40	8.40	8.49	8.66	8.66	8.66	8.66	9.37	9.37	9.37	9.37
		S/T	0.78	0.82	0.93	1.00	0.69	0.73	0.84	0.95	0.61	0.64	0.75	0.86	0.41	0.44	0.54	0.64
		PI	3.32	3.32	3.32	3.32	3.32	3.32	3.32	3.32	3.33	3.33	3.33	3.33	3.36	3.36	3.36	3.36
52.0	TC	7.11	7.11	7.19	7.28	7.34	7.34	7.34	7.42	7.59	7.59	7.59	7.68	8.25	8.25	8.25	8.25	
	S/T	0.82	0.85	0.98	1.00	0.72	0.76	0.88	1.00	0.62	0.66	0.78	0.89	0.41	0.45	0.55	0.66	
	PI	3.69	3.69	3.69	3.69	3.69	3.69	3.69	3.69	3.70	3.70	3.70	3.70	3.73	3.73	3.73	3.73	
1106	27.0	TC	10.03	10.03	10.11	10.23	10.34	10.34	10.34	10.46	10.63	10.63	10.63	10.75	11.46	11.46	11.46	11.46
		S/T	0.81	0.85	0.97	1.00	0.72	0.75	0.87	0.99	0.62	0.66	0.78	0.89	0.41	0.45	0.56	0.67
		PI	2.36	2.36	2.36	2.36	2.36	2.36	2.36	2.36	2.36	2.36	2.36	2.36	2.37	2.37	2.37	2.37
	30.0	TC	9.74	9.74	9.83	9.91	10.06	10.06	10.17	10.29	10.34	10.34	10.34	10.46	11.15	11.15	11.15	11.15
		S/T	0.82	0.86	0.99	1.00	0.72	0.76	0.88	1.00	0.63	0.67	0.79	0.91	0.41	0.45	0.56	0.67
		PI	2.50	2.50	2.50	2.50	2.50	2.50	2.50	2.50	2.50	2.50	2.50	2.50	2.51	2.51	2.51	2.51
	32.0	TC	9.54	9.54	9.62	9.71	9.85	9.85	9.94	10.03	10.14	10.14	10.14	10.26	10.95	10.95	10.95	10.95
		S/T	0.83	0.87	1.00	1.00	0.73	0.77	0.89	1.00	0.63	0.67	0.80	0.91	0.41	0.45	0.56	0.68
		PI	2.58	2.58	2.58	2.58	2.58	2.58	2.58	2.58	2.59	2.59	2.59	2.59	2.60	2.60	2.60	2.60
	35.0	TC	9.25	9.25	9.34	9.42	9.54	9.54	9.62	9.71	9.85	9.85	10.00	10.08	10.63	10.63	10.63	10.63
		S/T	0.84	0.88	1.00	1.00	0.74	0.78	0.91	1.00	0.64	0.68	0.80	0.92	0.41	0.45	0.57	0.69
		PI	2.73	2.73	2.73	2.73	2.73	2.73	2.73	2.73	2.74	2.74	2.74	2.74	2.74	2.74	2.74	2.74
	43.0	TC	8.53	8.59	8.68	8.77	8.82	8.82	8.91	8.99	9.10	9.10	9.14	9.22	9.84	9.84	9.84	9.84
		S/T	0.88	0.92	1.00	1.00	0.77	0.81	0.95	1.00	0.66	0.70	0.84	0.98	0.42	0.46	0.59	0.72
		PI	3.22	3.22	3.22	3.22	3.23	3.23	3.23	3.23	3.24	3.24	3.24	3.24	3.25	3.25	3.25	3.25
	46.0	TC	8.29	8.38	8.47	8.55	8.58	8.58	8.67	8.76	8.85	8.85	8.85	8.94	9.59	9.59	9.59	9.59
		S/T	0.90	0.94	1.00	1.00	0.78	0.83	0.97	1.00	0.67	0.71	0.86	1.00	0.42	0.46	0.59	0.73
		PI	3.40	3.40	3.40	3.40	3.41	3.41	3.41	3.41	3.42	3.42	3.42	3.42	3.44	3.44	3.44	3.44
52.0	TC	7.26	7.34	7.43	7.51	7.51	7.51	7.60	7.68	7.77	7.77	7.86	7.94	8.43	8.43	8.43	8.43	
	S/T	0.94	0.99	1.00	1.00	0.82	0.87	1.00	1.00	0.70	0.74	0.90	1.00	0.42	0.47	0.61	0.91	
	PI	3.78	3.78	3.78	3.78	3.79	3.79	3.79	3.79	3.80	3.80	3.80	3.80	3.83	3.83	3.83	3.83	
1324	27.0	TC	10.23	10.34	10.46	10.57	10.54	10.54	10.66	10.77	10.86	10.86	10.86	10.98	11.69	11.69	11.69	11.69
		S/T	0.87	0.91	1.00	1.00	0.76	0.81	0.94	1.00	0.66	0.70	0.84	0.97	0.42	0.45	0.58	0.71
		PI	2.41	2.41	2.41	2.41	2.41	2.41	2.41	2.41	2.41	2.41	2.41	2.41	2.42	2.42	2.42	2.42
	30.0	TC	9.94	10.03	10.11	10.23	10.26	10.26	10.37	10.49	10.54	10.54	10.54	10.66	11.38	11.38	11.38	11.38
		S/T	0.89	0.93	1.00	1.00	0.77	0.82	0.96	1.00	0.66	0.71	0.85	0.99	0.42	0.46	0.59	0.72
		PI	2.55	2.55	2.55	2.55	2.55	2.55	2.55	2.55	2.56	2.56	2.56	2.56	2.57	2.57	2.57	2.57
	32.0	TC	9.74	9.83	9.91	10.00	10.06	10.06	10.17	10.29	10.34	10.34	10.34	10.46	11.15	11.15	11.15	11.15
		S/T	0.90	0.94	1.00	1.00	0.78	0.82	0.97	1.00	0.67	0.71	0.86	1.00	0.42	0.46	0.59	0.73
		PI	2.64	2.64	2.64	2.64	2.64	2.64	2.64	2.64	2.64	2.64	2.64	2.64	2.66	2.66	2.66	2.66
	35.0	TC	9.45	9.54	9.62	9.71	9.74	9.74	9.83	9.91	10.06	10.06	10.20	10.31	10.83	10.83	10.83	10.83
		S/T	0.91	0.95	1.00	1.00	0.79	0.84	0.99	1.00	0.68	0.72	0.87	1.00	0.42	0.46	0.60	0.74
		PI	2.78	2.78	2.78	2.78	2.79	2.79	2.79	2.79	2.80	2.80	2.80	2.80	2.81	2.81	2.81	2.81
	43.0	TC	8.71	8.80	8.89	8.97	8.98	9.05	9.13	9.22	9.28	9.28	9.38	9.48	10.03	10.03	10.03	10.03
		S/T	0.96	1.00	1.00	1.00	0.83	0.88	1.00	1.00	0.70	0.75	0.91	1.00	0.42	0.47	0.62	0.90
		PI	3.28	3.28	3.28	3.28	3.29	3.29	3.29	3.29	3.30	3.30	3.30	3.30	3.33	3.33	3.33	3.33
	46.0	TC	8.47	8.55	8.64	8.73	8.73	8.82	8.91	9.00	9.03	9.03	9.11	9.20	9.76	9.76	9.76	9.76
		S/T	0.98	1.00	1.00	1.00	0.84	0.89	1.00	1.00	0.71	0.77	0.93	1.00	0.42	0.47	0.63	0.92
		PI	3.47	3.47	3.47	3.47	3.48	3.48	3.48	3.48	3.49	3.49	3.49	3.49	3.49	3.52	3.52	3.52
52.0	TC	7.40	7.49	7.57	7.66	7.66	7.74	7.83	7.91	7.91	7.91	8.00	8.08	8.60	8.60	8.60	8.60	
	S/T	1.00	1.00	1.00	1.00	0.88	0.94	1.00	1.00	0.75	0.80	0.99	1.00	0.43	0.48	0.66	0.97	
	PI	3.86	3.86	3.86	3.86	3.87	3.87	3.87	3.87	3.88	3.88	3.88	3.88	3.91	3.91	3.91	3.91	

TC:Total Cooling Capacity (kW)

S/T:Sensible Cooling Capacity Ratio

PI:Power Input(kW)

Note: The table shows the case where the operation frequency of a compressor is fixed.

38/42QSM048VT

INDOOR AIRFLOW (CFM)	OUTDOOR DB (°C)	ID WB (°C)	17.2				18.0				19.0				22.0				
		ID DB (°C)	24.4	25.0	27.0	29.0	24.4	25.0	27.0	29.0	24.4	25.0	27.0	29.0	24.4	25.0	27.0	29.0	
1165	27.0	TC	13.52	13.52	13.52	13.66	13.95	13.95	13.95	13.95	14.35	14.35	14.35	14.35	15.47	15.47	15.47	15.47	
		S/T	0.74	0.77	0.87	0.96	0.66	0.69	0.78	0.88	0.59	0.61	0.71	0.80	0.41	0.44	0.52	0.61	
		PI	3.29	3.29	3.29	3.29	3.30	3.30	3.30	3.30	3.30	3.30	3.30	3.30	3.30	3.30	3.30	3.30	3.30
	30.0	TC	13.14	13.14	13.14	13.29	13.55	13.55	13.55	13.69	13.95	13.95	13.95	13.95	15.04	15.04	15.04	15.04	
		S/T	0.75	0.78	0.88	0.97	0.67	0.70	0.79	0.89	0.59	0.62	0.71	0.81	0.41	0.44	0.53	0.61	
		PI	3.48	3.48	3.48	3.48	3.49	3.49	3.49	3.49	3.49	3.49	3.49	3.49	3.51	3.51	3.51	3.51	
	32.0	TC	12.89	12.89	13.00	13.14	13.29	13.29	13.29	13.43	13.69	13.69	13.69	13.69	14.75	14.75	14.75	14.75	
		S/T	0.75	0.78	0.88	0.98	0.67	0.70	0.80	0.90	0.59	0.62	0.72	0.81	0.41	0.44	0.53	0.62	
		PI	3.61	3.61	3.61	3.61	3.62	3.62	3.62	3.62	3.63	3.63	3.63	3.63	3.65	3.65	3.65	3.65	
	35.0	TC	12.48	12.48	12.60	12.71	12.89	12.89	12.89	13.00	13.29	13.29	13.49	13.29	14.32	14.32	14.32	14.32	
		S/T	0.76	0.79	0.90	1.00	0.68	0.71	0.81	0.91	0.60	0.63	0.72	0.83	0.41	0.44	0.53	0.62	
		PI	3.81	3.81	3.81	3.81	3.82	3.82	3.82	3.82	3.82	3.82	3.83	3.82	3.85	3.85	3.85	3.85	
	43.0	TC	12.23	12.23	12.35	12.48	12.62	12.62	12.62	12.74	13.03	13.03	13.08	13.03	14.10	14.10	14.10	14.10	
		S/T	0.79	0.82	0.94	1.00	0.70	0.73	0.84	0.95	0.61	0.64	0.75	0.86	0.41	0.44	0.54	0.64	
		PI	4.76	4.76	4.76	4.76	4.77	4.77	4.77	4.77	4.78	4.78	4.79	4.78	4.82	4.82	4.82	4.82	
	46.0	TC	12.18	12.18	12.31	12.44	12.57	12.57	12.57	12.70	12.99	12.99	12.99	12.99	14.08	14.08	14.08	14.08	
		S/T	0.80	0.84	0.96	1.00	0.71	0.74	0.86	0.97	0.62	0.65	0.77	0.88	0.41	0.44	0.55	0.65	
		PI	5.12	5.12	5.12	5.12	5.13	5.13	5.13	5.13	5.14	5.14	5.14	5.14	5.19	5.19	5.19	5.19	
	52.0	TC	9.77	9.77	9.85	9.94	10.11	10.11	10.22	10.34	10.45	10.45	10.45	10.56	11.36	11.36	11.36	11.36	
		S/T	0.84	0.88	1.00	1.00	0.73	0.77	0.90	1.00	0.64	0.67	0.80	0.92	0.41	0.45	0.56	0.68	
		PI	5.28	5.28	5.28	5.28	5.29	5.29	5.29	5.29	5.30	5.30	5.30	5.30	5.34	5.34	5.34	5.34	
	1429	27.0	TC	13.81	13.81	13.95	14.10	14.24	14.24	14.24	14.38	14.67	14.67	14.67	14.67	15.79	15.79	15.79	15.79
			S/T	0.79	0.83	0.94	1.00	0.70	0.73	0.85	0.96	0.61	0.65	0.76	0.87	0.41	0.44	0.55	0.65
			PI	3.36	3.36	3.36	3.36	3.36	3.36	3.36	3.36	3.37	3.37	3.37	3.37	3.37	3.37	3.37	3.37
30.0		TC	13.44	13.44	13.58	13.72	13.84	13.84	13.84	13.98	14.27	14.27	14.27	14.27	15.36	15.36	15.36	15.36	
		S/T	0.80	0.84	0.95	1.00	0.71	0.74	0.86	0.97	0.62	0.65	0.77	0.88	0.41	0.44	0.55	0.66	
		PI	3.56	3.56	3.56	3.56	3.56	3.56	3.56	3.56	3.56	3.56	3.56	3.56	3.58	3.58	3.58	3.58	
32.0		TC	13.15	13.15	13.29	13.44	13.58	13.58	13.58	13.72	13.98	13.98	13.98	14.13	15.07	15.07	15.07	15.07	
		S/T	0.81	0.85	0.96	1.00	0.71	0.75	0.87	0.98	0.62	0.66	0.77	0.88	0.41	0.44	0.55	0.66	
		PI	3.69	3.69	3.69	3.69	3.70	3.70	3.70	3.70	3.70	3.70	3.70	3.70	3.72	3.72	3.72	3.72	
35.0		TC	12.75	12.75	12.86	12.98	13.15	13.15	13.15	13.29	13.58	13.58	13.78	13.92	14.64	14.64	14.64	14.64	
		S/T	0.82	0.86	0.98	1.00	0.72	0.76	0.88	1.00	0.63	0.66	0.78	0.89	0.41	0.45	0.56	0.67	
		PI	3.89	3.89	3.89	3.89	3.90	3.90	3.90	3.90	3.90	3.90	3.91	3.90	3.90	3.90	3.90	3.90	
43.0		TC	12.53	12.62	12.75	12.87	12.94	12.94	13.03	13.17	13.36	13.36	13.42	13.55	14.44	14.44	14.44	14.44	
		S/T	0.85	0.89	1.00	1.00	0.75	0.79	0.92	1.00	0.65	0.68	0.82	0.94	0.41	0.45	0.57	0.69	
		PI	4.86	4.86	4.86	4.86	4.87	4.87	4.87	4.87	4.88	4.88	4.89	4.88	4.92	4.92	4.92	4.92	
46.0		TC	12.48	12.61	12.74	12.87	12.90	12.90	13.03	13.16	13.32	13.32	13.32	13.45	14.41	14.41	14.41	14.41	
		S/T	0.87	0.91	1.00	1.00	0.76	0.80	0.94	1.00	0.65	0.70	0.83	0.97	0.42	0.45	0.58	0.71	
		PI	5.22	5.22	5.22	5.22	5.23	5.23	5.23	5.23	5.25	5.25	5.25	5.25	5.30	5.30	5.30	5.30	
52.0		TC	10.03	10.14	10.26	10.37	10.37	10.37	10.48	10.60	10.71	10.71	10.71	10.83	11.62	11.62	11.62	11.62	
		S/T	0.91	0.96	1.00	1.00	0.79	0.84	0.99	1.00	0.68	0.72	0.87	1.00	0.42	0.46	0.60	0.91	
		PI	5.39	5.39	5.39	5.39	5.40	5.40	5.40	5.40	5.41	5.41	5.41	5.41	5.46	5.46	5.46	5.46	

Specifications

38/42QSM048VT																		
INDOOR AIRFLOW (CFM)	OUTDOOR DB (°C)	ID WB (°C)	17.2				18.0				19.0				22.0			
		ID DB (°C)	24.4	25.0	27.0	29.0	24.4	25.0	27.0	29.0	24.4	25.0	27.0	29.0	24.4	25.0	27.0	29.0
1676	27.0	TC	14.10	14.10	14.24	14.38	14.53	14.53	14.67	14.81	14.99	14.99	14.99	15.13	16.14	16.14	16.14	16.14
		S/T	0.84	0.88	1.00	1.00	0.74	0.78	0.90	1.00	0.64	0.68	0.80	0.93	0.41	0.45	0.57	0.69
		PI	3.43	3.43	3.43	3.43	3.43	3.43	3.43	3.43	3.43	3.44	3.44	3.44	3.44	3.44	3.44	3.44
	30.0	TC	13.69	13.84	13.98	14.13	14.13	14.13	14.27	14.41	14.56	14.56	14.56	14.70	15.68	15.68	15.68	15.68
		S/T	0.85	0.89	1.00	1.00	0.75	0.79	0.92	1.00	0.64	0.68	0.82	0.94	0.41	0.45	0.57	0.70
		PI	3.63	3.63	3.63	3.63	3.63	3.63	3.63	3.63	3.64	3.64	3.64	3.64	3.65	3.65	3.65	3.65
	32.0	TC	13.44	13.58	13.72	13.87	13.87	13.87	14.01	14.15	14.27	14.27	14.27	14.41	15.39	15.39	15.39	15.39
		S/T	0.86	0.90	1.00	1.00	0.75	0.79	0.93	1.00	0.65	0.69	0.82	0.95	0.41	0.45	0.58	0.70
		PI	3.76	3.76	3.76	3.76	3.76	3.76	3.76	3.76	3.77	3.77	3.77	3.77	3.79	3.79	3.79	3.79
	35.0	TC	13.03	13.18	13.32	13.47	13.44	13.44	13.58	13.72	13.87	13.87	14.07	14.21	14.96	14.96	14.96	14.96
		S/T	0.87	0.91	1.00	1.00	0.76	0.80	0.94	1.00	0.66	0.70	0.83	0.96	0.42	0.45	0.58	0.71
		PI	3.97	3.97	3.97	3.97	3.98	3.98	3.98	3.98	3.98	3.98	3.98	3.99	3.98	4.01	4.01	4.01
	43.0	TC	12.79	12.93	13.06	13.19	13.21	13.21	13.34	13.47	13.63	13.63	13.77	13.91	14.74	14.74	14.74	14.74
		S/T	0.91	0.96	1.00	1.00	0.79	0.84	0.99	1.00	0.68	0.72	0.88	1.00	0.42	0.46	0.60	0.90
		PI	4.96	4.96	4.96	4.96	4.97	4.97	4.97	4.97	4.98	4.98	4.99	4.98	5.02	5.02	5.02	5.02
	46.0	TC	12.74	12.87	13.00	13.13	13.16	13.16	13.29	13.42	13.58	13.58	13.70	13.83	14.70	14.70	14.70	14.70
		S/T	0.93	0.98	1.00	1.00	0.81	0.86	1.00	1.00	0.69	0.74	0.89	1.00	0.42	0.46	0.61	0.92
		PI	5.33	5.33	5.33	5.33	5.34	5.34	5.34	5.34	5.36	5.36	5.36	5.36	5.40	5.40	5.40	5.40
	52.0	TC	10.23	10.34	10.46	10.57	10.57	10.68	10.80	10.91	10.94	10.94	11.05	11.17	11.88	11.88	11.88	11.88
		S/T	0.98	1.00	1.00	1.00	0.85	0.90	1.00	1.00	0.72	0.77	0.94	1.00	0.42	0.47	0.63	0.97
		PI	5.50	5.50	5.50	5.50	5.51	5.51	5.51	5.51	5.52	5.52	5.52	5.52	5.57	5.57	5.57	5.57

TC: Total Cooling Capacity (kBtu/h)

S/T: Sensible Cooling Capacity Ratio

PI: Power Input(kW)

Note: The table shows the case where the operation frequency of a compressor is fixed.

38/42QSM060VT																			
INDOOR AIRFLOW (CFM)	OUTDOOR DB (°C)	ID WB (°C)	17.2				18.0				19.0				22.0				
		ID DB (°C)	24.4	25.0	27.0	29.0	24.4	25.0	27.0	29.0	24.4	25.0	27.0	29.0	24.4	25.0	27.0	29.0	
1453	27.0	TC	15.22	15.22	15.36	15.50	15.71	15.71	15.71	15.85	16.16	16.16	16.16	16.16	17.40	17.40	17.40	17.40	
		S/T	0.77	0.80	0.91	1.00	0.68	0.71	0.82	0.92	0.60	0.63	0.73	0.84	0.41	0.44	0.53	0.63	
		PI	3.71	3.71	3.71	3.71	3.72	3.72	3.72	3.72	3.72	3.72	3.72	3.72	3.72	3.73	3.73	3.73	3.73
	30.0	TC	14.79	14.79	14.93	15.07	15.25	15.25	15.25	15.39	15.71	15.71	15.71	15.71	16.94	16.94	16.94	16.94	
		S/T	0.78	0.81	0.92	1.00	0.69	0.72	0.83	0.93	0.60	0.64	0.74	0.85	0.41	0.44	0.54	0.64	
		PI	3.93	3.93	3.93	3.93	3.93	3.93	3.93	3.93	3.94	3.94	3.94	3.94	3.95	3.95	3.95	3.95	
	32.0	TC	14.50	14.50	14.64	14.79	14.96	14.96	14.96	15.10	15.42	15.42	15.42	15.42	16.62	16.62	16.62	16.62	
		S/T	0.78	0.82	0.93	1.00	0.69	0.73	0.84	0.94	0.61	0.64	0.75	0.85	0.41	0.44	0.54	0.64	
		PI	4.08	4.08	4.08	4.08	4.08	4.08	4.08	4.08	4.09	4.09	4.09	4.09	4.11	4.11	4.11	4.11	
	35.0	TC	14.07	14.07	14.21	14.36	14.50	14.50	14.50	14.64	14.96	14.96	15.19	14.96	16.14	16.14	16.14	16.14	
		S/T	0.79	0.83	0.94	1.00	0.70	0.73	0.85	0.96	0.61	0.64	0.75	0.87	0.41	0.44	0.54	0.65	
		PI	4.30	4.30	4.30	4.30	4.30	4.30	4.30	4.30	4.31	4.31	4.32	4.31	4.34	4.34	4.34	4.34	
	43.0	TC	13.31	13.31	13.44	13.57	13.74	13.74	13.83	13.96	14.18	14.18	14.24	14.29	15.34	15.34	15.34	15.34	
		S/T	0.82	0.86	0.99	1.00	0.72	0.76	0.88	1.00	0.63	0.67	0.79	0.90	0.41	0.45	0.56	0.67	
		PI	5.00	5.00	5.00	5.00	5.01	5.01	5.01	5.01	5.02	5.02	5.02	5.02	5.06	5.06	5.06	5.06	
	46.0	TC	13.03	13.03	13.16	13.28	13.46	13.46	13.58	13.70	13.89	13.89	13.89	14.04	15.04	15.04	15.04	15.04	
		S/T	0.84	0.88	1.00	1.00	0.73	0.77	0.90	1.00	0.64	0.67	0.80	0.92	0.41	0.45	0.57	0.68	
		PI	5.26	5.26	5.26	5.26	5.27	5.27	5.27	5.27	5.28	5.28	5.28	5.28	5.33	5.33	5.33	5.33	
	52.0	TC	11.13	11.24	11.36	11.47	11.50	11.50	11.62	11.73	11.88	11.88	11.88	11.99	12.91	12.91	12.91	12.91	
		S/T	0.88	0.92	1.00	1.00	0.76	0.81	0.95	1.00	0.66	0.70	0.84	0.97	0.42	0.45	0.58	0.71	
		PI	5.96	5.96	5.96	5.96	5.97	5.97	5.97	5.97	5.98	5.98	5.98	5.98	6.03	6.03	6.03	6.03	
	1735	27.0	TC	15.54	15.54	15.68	15.83	16.03	16.03	16.03	16.20	16.52	16.52	16.52	16.69	17.78	17.78	17.78	17.78
			S/T	0.82	0.86	0.98	1.00	0.72	0.76	0.88	1.00	0.63	0.66	0.78	0.90	0.41	0.45	0.56	0.67
			PI	3.79	3.79	3.79	3.79	3.79	3.79	3.79	3.79	3.80	3.80	3.80	3.80	3.80	3.80	3.80	3.80
30.0		TC	15.11	15.11	15.25	15.40	15.57	15.57	15.71	15.86	16.06	16.06	16.06	16.23	17.29	17.29	17.29	17.29	
		S/T	0.83	0.87	0.99	1.00	0.73	0.77	0.89	1.00	0.63	0.67	0.79	0.91	0.41	0.45	0.56	0.68	
		PI	4.01	4.01	4.01	4.01	4.01	4.01	4.01	4.01	4.02	4.02	4.02	4.02	4.04	4.04	4.04	4.04	
32.0		TC	14.82	14.82	14.96	15.11	15.28	15.28	15.42	15.57	15.74	15.74	15.74	15.88	16.98	16.98	16.98	16.98	
		S/T	0.83	0.87	1.00	1.00	0.73	0.77	0.90	1.00	0.64	0.67	0.80	0.92	0.41	0.45	0.56	0.68	
		PI	4.16	4.16	4.16	4.16	4.17	4.17	4.17	4.17	4.17	4.17	4.17	4.17	4.20	4.20	4.20	4.20	
35.0		TC	14.36	14.51	14.65	14.79	14.82	14.82	14.96	15.11	15.28	15.28	15.51	15.65	16.49	16.49	16.49	16.49	
		S/T	0.85	0.88	1.00	1.00	0.74	0.78	0.91	1.00	0.64	0.68	0.80	0.93	0.41	0.45	0.57	0.69	
		PI	4.39	4.39	4.39	4.39	4.39	4.39	4.39	4.39	4.40	4.40	4.41	4.40	4.40	4.40	4.40	4.40	
43.0		TC	13.48	13.61	13.74	13.86	13.92	13.92	14.06	14.21	14.37	14.37	14.43	14.58	15.53	15.53	15.53	15.53	
		S/T	0.89	0.93	1.00	1.00	0.77	0.81	0.96	1.00	0.66	0.71	0.85	0.98	0.42	0.46	0.59	0.72	
		PI	5.11	5.11	5.11	5.11	5.11	5.11	5.11	5.11	5.12	5.12	5.13	5.12	5.16	5.16	5.16	5.16	
46.0		TC	13.20	13.32	13.45	13.57	13.63	13.63	13.78	13.93	14.08	14.08	14.08	14.23	15.23	15.23	15.23	15.23	
		S/T	0.90	0.95	1.00	1.00	0.79	0.83	0.98	1.00	0.67	0.72	0.87	1.00	0.42	0.46	0.60	0.73	
		PI	5.37	5.37	5.37	5.37	5.38	5.38	5.38	5.38	5.39	5.39	5.39	5.39	5.44	5.44	5.44	5.44	
52.0		TC	11.27	11.38	11.50	11.61	11.64	11.64	11.75	11.87	12.04	12.04	12.15	12.27	13.06	13.06	13.06	13.06	
		S/T	0.95	1.00	1.00	1.00	0.82	0.87	1.00	1.00	0.70	0.75	0.91	1.00	0.42	0.47	0.62	0.91	
		PI	6.08	6.08	6.08	6.08	6.09	6.09	6.09	6.09	6.11	6.11	6.11	6.11	6.16	6.16	6.16	6.16	

Specifications

38/42QSM060VT																		
INDOOR AIRFLOW (CFM)	OUTDOOR DB (°C)	ID WB (°C)	17.2				18.0				19.0				22.0			
		ID DB (°C)	24.4	25.0	27.0	29.0	24.4	25.0	27.0	29.0	24.4	25.0	27.0	29.0	24.4	25.0	27.0	29.0
1982	27.0	TC	15.88	16.06	16.23	16.40	16.34	16.34	16.52	16.69	16.86	16.86	16.86	17.03	18.12	18.12	18.12	18.12
		S/T	0.86	0.90	1.00	1.00	0.75	0.79	0.93	1.00	0.65	0.69	0.82	0.95	0.41	0.45	0.58	0.70
		PI	3.87	3.87	3.87	3.87	3.87	3.87	3.87	3.87	3.87	3.87	3.87	3.87	3.87	3.88	3.88	3.88
	30.0	TC	15.42	15.57	15.71	15.86	15.88	15.88	16.06	16.23	16.37	16.37	16.37	16.54	17.64	17.64	17.64	17.64
		S/T	0.87	0.91	1.00	1.00	0.76	0.80	0.94	1.00	0.66	0.70	0.84	0.97	0.42	0.45	0.58	0.71
		PI	4.09	4.09	4.09	4.09	4.10	4.10	4.10	4.10	4.10	4.10	4.10	4.10	4.12	4.12	4.12	4.12
	32.0	TC	15.11	15.25	15.40	15.54	15.60	15.60	15.74	15.88	16.06	16.06	16.06	16.23	17.32	17.32	17.32	17.32
		S/T	0.88	0.92	1.00	1.00	0.77	0.81	0.95	1.00	0.66	0.70	0.84	0.98	0.42	0.46	0.59	0.72
		PI	4.25	4.25	4.25	4.25	4.25	4.25	4.25	4.25	4.25	4.25	4.25	4.25	4.27	4.27	4.27	4.27
	35.0	TC	14.65	14.79	14.94	15.08	15.11	15.11	15.25	15.40	15.60	15.60	<b>15.83</b>	16.00	16.80	16.80	16.80	16.80
		S/T	0.89	0.93	1.00	1.00	0.78	0.82	0.97	1.00	0.67	0.71	<b>0.85</b>	0.99	0.42	0.46	0.59	0.73
		PI	4.48	4.48	4.48	4.48	4.48	4.48	4.48	4.48	4.49	4.49	<b>4.50</b>	4.49	4.52	4.52	4.52	4.52
	43.0	TC	13.74	13.86	13.99	14.14	14.19	14.19	14.34	14.49	14.65	14.65	14.82	14.98	15.84	15.84	15.84	15.84
		S/T	0.94	0.98	1.00	1.00	0.81	0.86	1.00	1.00	0.69	0.74	0.89	1.00	0.42	0.47	0.61	0.90
		PI	5.21	5.21	5.21	5.21	5.21	5.21	5.21	5.21	5.22	5.22	5.23	5.22	5.27	5.27	5.27	5.27
	46.0	TC	13.45	13.57	13.69	13.84	13.90	13.90	14.05	14.20	14.35	14.35	14.50	<b>14.65</b>	15.53	15.53	15.53	15.53
		S/T	0.96	1.00	1.00	1.00	0.83	0.88	1.00	1.00	0.70	0.75	0.91	<b>1.00</b>	0.42	0.47	0.62	0.92
		PI	5.48	5.48	5.48	5.48	5.49	5.49	5.49	5.49	5.50	5.50	5.50	<b>5.50</b>	5.55	5.55	5.55	5.55
	52.0	TC	11.50	11.61	11.73	11.84	11.90	12.01	12.12	12.24	12.30	12.30	12.41	12.52	13.35	13.35	13.35	13.35
		S/T	1.00	1.00	1.00	1.00	0.87	0.92	1.00	1.00	0.73	0.79	0.97	1.00	0.43	0.48	0.65	0.97
		PI	6.20	6.20	6.20	6.20	6.22	6.22	6.22	6.22	6.22	6.23	6.23	6.23	6.23	6.27	6.27	6.27

TC: Total Cooling Capacity (kBtu/h)

S/T: Sensible Cooling Capacity Ratio

PI: Power Input(kW)

Note: The table shows the case where the operation frequency of a compressor is fixed.

## 6.2 Heating

		18k				[SI_Unit]			
INDOOR AIRFLOW (CMH)	OUTDOOR DB(°C)	HEATING PERFORMANCE AT INDOOR DRY BULB TEMPERATURE							
		TC:TOTAL CAPACITY IN KILOWATTS (KW)				PI:TOTAL POWER IN KILOWATTS (KW)			
		Indoor Conditions (DB °C )				Indoor Conditions (DB °C )			
		16.0	20.0	22.0	24.0	16.0	20.0	22.0	24.0
632	-15.0	3.88	3.85	3.83	3.80	1.44	1.48	1.47	1.49
	-10.0	4.14	4.11	4.09	4.06	1.53	1.58	1.57	1.59
	-7.0	4.34	4.31	4.28	4.25	1.63	1.68	1.67	1.69
	-5.6	4.48	4.46	4.43	4.40	1.60	1.63	1.65	1.66
	-2.8	4.63	4.57	4.54	4.51	1.57	1.60	1.61	1.63
	0.0	4.69	4.63	4.60	4.57	1.53	1.56	1.57	1.59
	2.8	4.92	4.86	4.83	4.80	1.51	1.54	1.55	1.56
	5.6	5.32	5.27	5.24	5.18	1.49	1.52	1.53	1.54
	7.0	5.78	5.72	5.60	5.54	1.48	1.50	1.52	1.53
	11.1	6.07	5.98	5.92	5.89	1.44	1.46	1.47	1.49
	13.9	6.30	6.21	6.15	6.12	1.41	1.43	1.44	1.46
	16.7	6.53	6.44	6.38	6.36	1.38	1.40	1.41	1.42
18.0	6.65	6.56	6.50	6.47	1.37	1.39	1.40	1.41	
805	-15.0	3.96	3.93	3.91	3.88	1.45	1.50	1.49	1.51
	-10.0	4.22	4.20	4.17	4.14	1.54	1.60	1.59	1.61
	-7.0	4.43	4.40	4.37	4.34	1.64	1.70	1.69	1.71
	-5.6	4.57	4.54	4.51	4.48	1.62	1.65	1.67	1.68
	-2.8	4.72	4.66	4.63	4.60	1.58	1.61	1.63	1.64
	0.0	4.77	4.72	4.69	4.66	1.55	1.57	1.59	1.60
	2.8	5.03	4.95	4.92	4.89	1.53	1.55	1.56	1.58
	5.6	5.44	5.35	5.32	5.29	1.50	1.53	1.54	1.55
	7.0	5.93	5.83	5.72	5.66	1.50	1.51	1.53	1.54
	11.1	6.18	6.09	6.07	6.01	1.45	1.47	1.49	1.50
	13.9	6.41	6.33	6.30	6.24	1.42	1.44	1.45	1.47
	16.7	6.67	6.56	6.53	6.47	1.39	1.41	1.42	1.43
18.0	6.79	6.67	6.65	6.59	1.38	1.40	1.41	1.42	
973	-15.0	4.01	3.98	3.96	3.93	1.46	1.52	1.51	1.52
	-10.0	4.28	4.25	4.23	4.20	1.56	1.62	1.61	1.63
	-7.0	4.48	4.46	4.43	4.40	1.66	1.72	1.71	1.73
	-5.6	4.63	4.60	4.57	4.54	1.64	1.67	1.69	1.70
	-2.8	4.77	4.72	4.69	4.66	1.60	1.63	1.65	1.66
	0.0	4.83	4.77	4.74	4.72	1.57	1.59	1.61	1.62
	2.8	5.06	5.00	4.98	4.95	1.54	1.57	1.58	1.60
	5.6	5.50	5.41	5.38	5.35	1.52	1.55	1.56	1.57
	7.0	5.99	5.89	5.77	5.72	1.51	1.53	1.55	1.56
	11.1	6.24	6.15	6.12	6.07	1.47	1.49	1.50	1.51
	13.9	6.47	6.38	6.36	6.30	1.44	1.46	1.47	1.48
	16.7	6.73	6.62	6.59	6.53	1.41	1.43	1.44	1.45
18.0	6.85	6.73	6.70	6.65	1.40	1.41	1.42	1.43	

Note: The table shows the case where the operation frequency of a compressor is fixed.

24k								[SI_Unit]	
INDOOR AIRFLOW (CMH)	HEATING PERFORMANCE AT INDOOR DRY BULB TEMPERATURE								
	OUTDOOR DB(°C)	TC:TOTAL CAPACITY IN KILOWATTS (KW)				PI:TOTAL POWER IN KILOWATTS (KW)			
		Indoor Conditions (DB °C )				Indoor Conditions (DB °C )			
		16.0	20.0	22.0	24.0	16.0	20.0	22.0	24.0
880	-15.0	5.23	5.18	5.13	5.11	2.00	2.07	2.06	2.08
	-10.0	5.59	5.53	5.48	5.45	2.13	2.20	2.20	2.21
	-7.0	5.85	5.80	5.74	5.71	2.26	2.34	2.33	2.35
	-5.6	6.03	5.97	5.91	5.88	2.23	2.27	2.29	2.31
	-2.8	6.17	6.11	6.06	6.03	2.18	2.22	2.23	2.25
	0.0	6.26	6.17	6.14	6.08	2.13	2.16	2.18	2.20
	2.8	6.55	6.46	6.43	6.37	2.10	2.13	2.14	2.16
	5.6	7.10	6.98	6.95	6.90	2.06	2.10	2.11	2.13
	7.0	7.69	7.56	7.39	7.36	2.05	2.07	2.10	2.12
	11.1	8.00	7.88	7.82	7.77	1.99	2.02	2.03	2.04
	13.9	8.29	8.17	8.11	8.06	1.94	1.97	1.98	2.00
	16.7	8.61	8.49	8.43	8.35	1.90	1.92	1.94	1.95
18.0	8.75	8.64	8.55	8.49	1.88	1.90	1.91	1.92	
1101	-15.0	5.35	5.28	5.25	5.22	2.02	2.09	2.08	2.09
	-10.0	5.71	5.63	5.61	5.58	2.16	2.23	2.21	2.23
	-7.0	5.99	5.90	5.87	5.84	2.29	2.36	2.35	2.37
	-5.6	6.14	6.06	6.03	6.00	2.25	2.29	2.31	2.33
	-2.8	6.29	6.23	6.17	6.14	2.20	2.24	2.25	2.27
	0.0	6.37	6.29	6.26	6.20	2.14	2.18	2.20	2.21
	2.8	6.66	6.58	6.55	6.49	2.12	2.14	2.16	2.18
	5.6	7.21	7.13	7.07	7.04	2.08	2.12	2.13	2.14
	7.0	7.80	7.71	7.54	7.51	2.07	2.09	2.12	2.13
	11.1	8.14	8.03	8.00	7.94	2.00	2.03	2.05	2.06
	13.9	8.46	8.35	8.29	8.23	1.96	1.99	2.00	2.01
	16.7	8.78	8.64	8.58	8.52	1.91	1.94	1.95	1.96
18.0	8.93	8.78	8.72	8.67	1.89	1.92	1.93	1.94	
1367	-15.0	5.39	5.34	5.31	5.26	2.04	2.11	2.10	2.12
	-10.0	5.75	5.70	5.67	5.62	2.18	2.25	2.24	2.26
	-7.0	6.03	5.97	5.94	5.88	2.31	2.39	2.38	2.40
	-5.6	6.20	6.14	6.11	6.06	2.28	2.32	2.34	2.36
	-2.8	6.37	6.29	6.26	6.20	2.22	2.26	2.28	2.30
	0.0	6.43	6.35	6.32	6.29	2.17	2.20	2.22	2.24
	2.8	6.75	6.66	6.61	6.58	2.14	2.17	2.18	2.20
	5.6	7.30	7.21	7.16	7.10	2.11	2.14	2.14	2.16
	7.0	7.89	7.80	7.62	7.56	2.09	2.11	2.14	2.16
	11.1	8.23	8.14	8.09	8.03	2.03	2.05	2.07	2.08
	13.9	8.55	8.43	8.38	8.32	1.98	2.01	2.02	2.03
	16.7	8.87	8.75	8.69	8.61	1.93	1.96	1.97	1.98
18.0	9.01	8.90	8.84	8.75	1.91	1.94	1.95	1.96	

Note: The table shows the case where the operation frequency of a compressor is fixed.

30k [SI_Unit]									
INDOOR AIRFLOW (CMH)	HEATING PERFORMANCE AT INDOOR DRY BULB TEMPERATURE								
	OUTDOOR DB ( °C )	TC : TOTAL CAPACITY IN KILOWATTS				PI : TOTAL POWER IN KILOWATTS			
		Indoor Conditions (DB °C )				Indoor Conditions (DB °C)			
		16.0	20.0	22.0	24.0	16.0	20.0	22.0	24.0
990	-15.0	5.20	5.15	5.11	5.08	1.40	1.43	1.50	1.54
	-10.0	5.56	5.50	5.45	5.43	1.49	1.53	1.61	1.64
	-7.0	5.82	5.77	5.71	5.68	1.59	1.63	1.71	1.75
	-5.6	6.17	6.11	6.06	6.03	1.64	1.72	1.76	1.79
	-2.8	6.52	6.43	6.37	6.35	1.74	1.82	1.86	1.90
	0.0	6.75	6.66	6.61	6.58	1.84	1.93	1.97	2.02
	2.8	7.24	7.16	7.10	7.04	1.97	2.06	2.11	2.16
	5.6	8.03	7.91	7.85	7.79	2.09	2.20	2.25	2.30
	7.0	8.87	8.74	8.48	8.42	2.17	2.36	2.32	2.38
	11.1	9.38	9.26	9.20	9.15	2.34	2.45	2.51	2.56
	13.9	9.90	9.75	9.70	9.64	2.46	2.57	2.63	2.69
16.7	10.39	10.25	10.19	10.13	2.57	2.70	2.76	2.82	
18.0	10.63	10.51	10.42	10.36	2.63	2.75	2.82	2.88	
1210	-15.0	5.30	5.25	5.20	5.18	1.42	1.45	1.51	1.55
	-10.0	5.66	5.61	5.55	5.53	1.51	1.55	1.61	1.65
	-7.0	5.93	5.87	5.82	5.79	1.61	1.64	1.72	1.76
	-5.6	6.29	6.23	6.17	6.14	1.65	1.74	1.77	1.81
	-2.8	6.64	6.55	6.52	6.46	1.76	1.84	1.88	1.92
	0.0	6.87	6.78	6.75	6.69	1.85	1.95	1.99	2.04
	2.8	7.39	7.30	7.24	7.19	1.98	2.08	2.13	2.18
	5.6	8.17	8.06	8.03	7.97	2.11	2.22	2.27	2.32
	7.0	9.04	8.92	8.65	8.59	2.19	2.38	2.34	2.40
	11.1	9.58	9.46	9.41	9.32	2.36	2.47	2.53	2.59
	13.9	10.10	9.96	9.90	9.84	2.48	2.59	2.65	2.71
16.7	10.63	10.48	10.39	10.34	2.59	2.72	2.78	2.84	
18.0	10.86	10.71	10.65	10.57	2.65	2.78	2.84	2.90	
1420	-15.0	5.38	5.31	5.29	5.24	1.43	1.46	1.53	1.57
	-10.0	5.75	5.67	5.64	5.59	1.52	1.56	1.63	1.67
	-7.0	6.02	5.94	5.91	5.86	1.62	1.66	1.74	1.77
	-5.6	6.37	6.29	6.26	6.20	1.67	1.75	1.78	1.82
	-2.8	6.69	6.61	6.58	6.52	1.77	1.85	1.90	1.94
	0.0	6.95	6.87	6.81	6.75	1.87	1.96	2.01	2.06
	2.8	7.48	7.36	7.33	7.27	2.00	2.10	2.15	2.20
	5.6	8.26	8.14	8.08	8.03	2.13	2.23	2.29	2.34
	7.0	9.13	9.00	8.74	8.68	2.20	2.40	2.36	2.42
	11.1	9.67	9.55	9.49	9.41	2.38	2.49	2.55	2.61
	13.9	10.19	10.05	9.99	9.93	2.50	2.62	2.68	2.74
16.7	10.71	10.57	10.48	10.42	2.61	2.74	2.80	2.87	
18.0	10.95	10.80	10.74	10.65	2.67	2.80	2.86	2.93	

Note: The table shows the case where the operation frequency of a compressor is fixed.

36k								[SI_Unit]	
INDOOR AIRFLOW (CMH)	HEATING PERFORMANCE AT INDOOR DRY BULB TEMPERATURE								
	OUTDOOR DB(°C)	TC:TOTAL CAPACITY IN KILOWATTS (KW)				PI:TOTAL POWER IN KILOWATTS (KW)			
		Indoor Conditions (DB °C )				Indoor Conditions (DB °C )			
		16.0	20.0	22.0	24.0	16.0	20.0	22.0	24.0
1360	-15.0	6.10	6.03	6.00	5.95	2.55	2.64	2.60	2.62
	-10.0	6.51	6.43	6.41	6.35	2.72	2.81	2.77	2.79
	-7.0	6.82	6.74	6.71	6.66	2.89	2.99	2.95	2.97
	-5.6	7.09	7.00	6.97	6.91	2.83	2.86	2.88	2.90
	-2.8	7.35	7.26	7.21	7.18	2.71	2.74	2.76	2.78
	0.0	7.50	7.41	7.35	7.32	2.60	2.63	2.64	2.65
	2.8	7.96	7.84	7.79	7.73	2.51	2.53	2.54	2.56
	5.6	8.66	8.54	8.48	8.43	2.42	2.44	2.45	2.46
	7.0	9.44	9.31	9.08	9.02	2.39	2.36	2.41	2.42
	11.1	9.92	9.77	9.72	9.66	2.24	2.25	2.26	2.26
	13.9	10.35	10.21	10.15	10.06	2.14	2.15	2.15	2.15
	16.7	10.79	10.64	10.56	10.50	2.04	2.04	2.04	2.04
18.0	10.99	10.85	10.76	10.70	1.99	1.99	1.99	1.99	
1880	-15.0	6.23	6.15	6.13	6.08	2.57	2.66	2.62	2.64
	-10.0	6.65	6.57	6.54	6.49	2.74	2.84	2.79	2.81
	-7.0	6.97	6.88	6.86	6.80	2.91	3.01	2.97	2.99
	-5.6	7.23	7.15	7.12	7.06	2.85	2.89	2.90	2.92
	-2.8	7.50	7.41	7.35	7.32	2.74	2.77	2.78	2.80
	0.0	7.67	7.55	7.53	7.47	2.62	2.65	2.66	2.68
	2.8	8.11	7.99	7.96	7.90	2.53	2.56	2.57	2.58
	5.6	8.86	8.72	8.66	8.60	2.44	2.46	2.47	2.48
	7.0	9.66	9.50	9.25	9.19	2.41	2.38	2.43	2.44
	11.1	10.12	9.98	9.92	9.83	2.26	2.27	2.27	2.28
	13.9	10.56	10.41	10.35	10.27	2.16	2.16	2.17	2.17
	16.7	11.02	10.85	10.79	10.70	2.06	2.06	2.06	2.06
18.0	11.22	11.08	10.99	10.91	2.01	2.01	2.00	2.00	
2250	-15.0	6.26	6.21	6.16	6.13	2.60	2.69	2.65	2.67
	-10.0	6.68	6.63	6.58	6.55	2.77	2.87	2.83	2.85
	-7.0	7.00	6.94	6.89	6.86	2.95	3.05	3.01	3.03
	-5.6	7.29	7.23	7.18	7.15	2.88	2.92	2.94	2.95
	-2.8	7.55	7.47	7.44	7.38	2.77	2.80	2.81	2.83
	0.0	7.73	7.64	7.58	7.53	2.65	2.68	2.69	2.70
	2.8	8.19	8.08	8.02	7.96	2.56	2.58	2.59	2.60
	5.6	8.95	8.83	8.77	8.69	2.47	2.48	2.49	2.50
	7.0	9.73	9.60	9.37	9.31	2.43	2.40	2.46	2.46
	11.1	10.21	10.09	10.01	9.95	2.28	2.29	2.29	2.30
	13.9	10.67	10.53	10.47	10.38	2.18	2.18	2.18	2.18
	16.7	11.14	10.96	10.91	10.82	2.07	2.07	2.07	2.07
18.0	11.34	11.20	11.11	11.02	2.02	2.02	2.02	2.01	

Note: The table shows the case where the operation frequency of a compressor is fixed.

48K								[SI_Unit]	
INDOOR AIRFLOW (CMH)	HEATING PERFORMANCE AT INDOOR DRY BULB TEMPERATURE								
	OUTDOOR DB(°C)	TC:TOTAL CAPACITY IN KILOWATTS (KW)				PI:TOTAL POWER IN KILOWATTS (KW)			
		Indoor Conditions (DB °C )				Indoor Conditions (DB °C )			
		16.0	20.0	22.0	24.0	16.0	20.0	22.0	24.0
1980	-15.0	10.52	10.40	10.33	10.28	4.53	4.68	4.63	4.67
	-10.0	11.24	11.11	11.03	10.97	4.83	4.99	4.94	4.98
	-7.0	11.77	11.63	11.55	11.50	5.13	5.30	5.25	5.29
	-5.6	12.30	12.16	12.07	12.01	5.03	5.11	5.15	5.19
	-2.8	12.80	12.62	12.56	12.48	4.88	4.95	4.98	5.02
	0.0	13.11	12.94	12.85	12.77	4.72	4.78	4.82	4.85
	2.8	13.96	13.75	13.67	13.58	4.61	4.68	4.70	4.73
	5.6	15.26	15.06	14.97	14.86	4.50	4.56	4.58	4.61
	7.0	16.70	16.48	16.04	15.93	4.44	4.44	4.52	4.55
	11.1	17.58	17.35	17.23	17.12	4.25	4.30	4.32	4.34
	13.9	18.42	18.16	18.04	17.90	4.12	4.15	4.17	4.19
16.7	19.23	18.97	18.83	18.71	3.98	4.01	4.03	4.04	
18.0	19.64	19.35	19.23	19.09	3.92	3.94	3.96	3.97	
2424	-15.0	10.73	10.60	10.56	10.48	4.57	4.73	4.68	4.72
	-10.0	11.46	11.32	11.27	11.19	4.88	5.04	5.00	5.03
	-7.0	12.00	11.86	11.81	11.72	5.18	5.36	5.31	5.35
	-5.6	12.53	12.39	12.33	12.24	5.09	5.17	5.21	5.25
	-2.8	13.06	12.88	12.80	12.74	4.93	5.00	5.04	5.07
	0.0	13.40	13.23	13.11	13.03	4.77	4.83	4.87	4.90
	2.8	14.25	14.04	13.96	13.87	4.66	4.71	4.74	4.77
	5.6	15.58	15.38	15.29	15.17	4.55	4.60	4.63	4.66
	7.0	17.05	16.83	16.39	16.27	4.49	4.49	4.56	4.59
	11.1	17.96	17.73	17.61	17.49	4.29	4.34	4.35	4.37
	13.9	18.80	18.57	18.42	18.31	4.16	4.19	4.21	4.23
16.7	19.64	19.38	19.26	19.12	4.02	4.05	4.06	4.08	
18.0	20.08	19.78	19.64	19.49	3.95	3.98	3.99	4.00	
2835	-15.0	10.84	10.71	10.64	10.56	4.61	4.77	4.73	4.76
	-10.0	11.57	11.44	11.36	11.28	4.92	5.09	5.04	5.08
	-7.0	12.12	11.98	11.90	11.82	5.23	5.41	5.36	5.40
	-5.6	12.68	12.53	12.45	12.36	5.14	5.22	5.26	5.30
	-2.8	13.17	13.03	12.94	12.85	4.98	5.05	5.09	5.12
	0.0	13.52	13.35	13.26	13.17	4.81	4.88	4.92	4.95
	2.8	14.39	14.19	14.10	13.99	4.70	4.76	4.79	4.82
	5.6	15.75	15.55	15.44	15.35	4.59	4.65	4.68	4.69
	7.0	17.22	17.00	16.54	16.45	4.53	4.53	4.61	4.64
	11.1	18.13	17.90	17.78	17.67	4.34	4.37	4.39	4.41
	13.9	19.00	18.74	18.62	18.48	4.20	4.24	4.25	4.27
16.7	19.84	19.58	19.44	19.32	4.06	4.09	4.11	4.12	
18.0	20.28	19.99	19.84	19.70	4.00	4.02	4.04	4.05	

Note: The table shows the case where the operation frequency of a compressor is fixed.

60K								[SI_Unit]	
INDOOR AIRFLOW (CMH)	HEATING PERFORMANCE AT INDOOR DRY BULB TEMPERATURE								
	OUTDOOR DB(°C)	TC:TOTAL CAPACITY IN KILOWATTS (KW)				PI:TOTAL POWER IN KILOWATTS (KW)			
		Indoor Conditions (DB °C )				Indoor Conditions (DB °C )			
		16.0	20.0	22.0	24.0	16.0	20.0	22.0	24.0
2470	-15.0	9.20	9.08	9.03	8.96	3.39	3.49	3.54	3.59
	-10.0	9.83	9.70	9.65	9.57	3.62	3.72	3.77	3.83
	-7.0	10.29	10.16	10.10	10.02	3.84	3.95	4.01	4.07
	-5.6	11.06	10.91	10.86	10.77	3.85	3.97	4.03	4.09
	-2.8	11.81	11.64	11.58	11.49	3.90	4.03	4.09	4.15
	0.0	12.39	12.22	12.13	12.05	3.95	4.08	4.15	4.21
	2.8	13.47	13.26	13.18	13.09	4.05	4.18	4.25	4.31
	5.6	15.03	14.83	14.72	14.63	4.15	4.28	4.35	4.42
	7.0	16.70	16.48	15.93	15.81	4.20	4.41	4.40	4.47
	11.1	17.84	17.61	17.49	17.38	4.31	4.45	4.52	4.59
	13.9	18.91	18.65	18.54	18.39	4.38	4.53	4.60	4.67
16.7	19.99	19.73	19.58	19.44	4.46	4.60	4.68	4.75	
18.0	20.48	20.22	20.07	19.96	4.49	4.64	4.72	4.79	
2945	-15.0	9.40	9.28	9.23	9.16	3.42	3.52	3.57	3.63
	-10.0	10.03	9.91	9.85	9.78	3.64	3.76	3.81	3.87
	-7.0	10.51	10.38	10.32	10.24	3.87	3.99	4.05	4.11
	-5.6	11.29	11.15	11.09	11.00	3.89	4.01	4.07	4.13
	-2.8	12.07	11.90	11.81	11.73	3.94	4.07	4.13	4.19
	0.0	12.65	12.48	12.39	12.31	3.99	4.12	4.19	4.25
	2.8	13.76	13.55	13.47	13.35	4.09	4.22	4.29	4.35
	5.6	15.35	15.15	15.03	14.95	4.19	4.32	4.39	4.46
	7.0	17.05	16.82	16.27	16.16	4.24	4.45	4.44	4.51
	11.1	18.22	17.96	17.84	17.72	4.35	4.49	4.56	4.63
	13.9	19.29	19.06	18.91	18.80	4.42	4.57	4.64	4.71
16.7	20.39	20.13	19.99	19.87	4.49	4.64	4.72	4.79	
18.0	20.91	20.65	20.51	20.36	4.53	4.68	4.76	4.83	
3365	-15.0	9.49	9.37	9.32	9.25	3.45	3.56	3.62	3.67
	-10.0	10.13	10.00	9.95	9.87	3.68	3.79	3.86	3.91
	-7.0	10.61	10.48	10.42	10.34	3.91	4.03	4.10	4.16
	-5.6	11.41	11.26	11.20	11.12	3.93	4.05	4.11	4.18
	-2.8	12.19	12.02	11.93	11.87	3.98	4.11	4.17	4.24
	0.0	12.77	12.60	12.51	12.42	4.03	4.17	4.23	4.30
	2.8	13.90	13.70	13.58	13.50	4.13	4.27	4.33	4.40
	5.6	15.50	15.30	15.18	15.09	4.23	4.37	4.44	4.51
	7.0	17.22	17.00	16.42	16.33	4.28	4.50	4.49	4.56
	11.1	18.39	18.16	18.04	17.93	4.40	4.54	4.61	4.68
	13.9	19.49	19.23	19.12	19.00	4.47	4.62	4.69	4.77
16.7	20.60	20.33	20.19	20.07	4.55	4.70	4.77	4.85	
18.0	21.15	20.86	20.71	20.60	4.58	4.74	4.81	4.89	

Note: The table shows the case where the operation frequency of a compressor is fixed.

## 7. Capacity Correction Factor for Height Difference

Model	18k		Pipe Length (m)			
Cooling			5	10	15	25
Height difference H (m)	Indoor Upper than Outdoor	15			0.937	0.918
		10		0.971	0.947	0.927
		5	0.995	0.980	0.956	0.937
		0	1.000	0.985	0.961	0.941
	Outdoor Upper than Indoor	-5	1.000	0.985	0.961	0.941
		-10		0.985	0.961	0.941
		-15			0.961	0.941
Heating			5	10	15	25
Height difference H (m)	Indoor Upper than Outdoor	15			0.991	0.986
		10		0.996	0.991	0.986
		5	1.000	0.996	0.991	0.986
		0	1.000	0.996	0.991	0.986
	Outdoor Upper than Indoor	-5	0.992	0.989	0.983	0.978
		-10		0.981	0.975	0.970
		-15			0.967	0.962

Note: model 42QSM018VSG/38QSM0318SG currently can't apply the long piping over 25 meters.

Model	24k		Pipe Length (m)							
Cooling/Heating			5	10	15	25	35	45	50	55
Height difference H (m)	Indoor Upper than Outdoor	15			0.920	0.870	0.820	0.770	0.729	0.677
		10		0.960	0.934	0.884	0.833	0.782	0.740	0.688
		5	0.995	0.969	0.944	0.893	0.841	0.790	0.747	0.695
		0	1.000	0.974	0.949	0.897	0.846	0.794	0.751	0.698
	Outdoor Upper than Indoor	-5	0.995	0.969	0.944	0.893	0.841	0.790	0.747	0.695
		-10		0.960	0.934	0.884	0.833	0.782	0.740	0.688
		-15			0.920	0.870	0.820	0.770	0.729	0.677
		-25				0.857	0.808	0.758	0.718	0.667
		-35					0.796	0.747	0.707	0.657
		-45						0.736	0.697	0.647

Model	30K		Pipe Length (m)					
Cooling			5	10	15	20	25	30
Height difference H (m)	Indoor Upper than Outdoor	20				0.909	0.894	0.878
		15			0.939	0.923	0.907	0.892
		10		0.969	0.953	0.937	0.921	0.905
		5	0.995	0.979	0.963	0.947	0.931	0.915
		<b>0</b>	<b>1.000</b>	<b>0.984</b>	<b>0.968</b>	<b>0.951</b>	<b>0.935</b>	<b>0.919</b>
	Outdoor Upper than Indoor	-5	1.000	0.984	0.968	0.951	0.935	0.919
		-10		0.984	0.968	0.951	0.935	0.919
		-15			0.968	0.951	0.935	0.919
		-20				0.951	0.935	0.919
	<b>Heating</b>			<b>5</b>	<b>10</b>	<b>15</b>	<b>20</b>	<b>25</b>
Height difference H (m)	Indoor Upper than Outdoor	20				0.984	0.978	0.973
		15			0.989	0.984	0.978	0.973
		10		0.995	0.989	0.984	0.978	0.973
		5	1.000	0.995	0.989	0.984	0.978	0.973
		<b>0</b>	<b>1.000</b>	<b>0.995</b>	<b>0.989</b>	<b>0.984</b>	<b>0.978</b>	<b>0.973</b>
	Outdoor Upper than Indoor	-5	0.992	0.987	0.981	0.976	0.970	0.965
		-10		0.979	0.973	0.968	0.963	0.957
		-15			0.966	0.960	0.955	0.950
		-20				0.953	0.947	0.942

Model	36k		Pipe Length (m)							
Cooling/Heating			5	10	15	25	35	45	50	55
Height difference H (m)	Indoor Upper than Outdoor	20				0.857	0.808	0.759	0.718	0.667
		15			0.920	0.870	0.820	0.770	0.729	0.677
		10		0.960	0.934	0.884	0.833	0.782	0.740	0.688
		5	0.995	0.969	0.944	0.893	0.841	0.790	0.747	0.695
		0	1.000	0.974	0.949	0.897	0.846	0.794	0.751	0.698
	Outdoor Upper than Indoor	-5	0.995	0.969	0.944	0.893	0.841	0.790	0.747	0.695
		-10		0.960	0.934	0.884	0.833	0.782	0.740	0.688
		-15			0.920	0.870	0.820	0.770	0.729	0.677
		-25				0.857	0.808	0.759	0.718	0.667
		-35					0.796	0.748	0.707	0.657
		-45						0.736	0.697	0.647

Note: model 42QSM036VSP/38QSM036VSP currently can't apply the long piping over 30 meters and vertical not over 20 meters in heating mode.

Model	48k		Pipe Length (m)					
Cooling			5	10	20	30	40	50
Height difference H (m)	Indoor Upper than Outdoor	30				0.967	0.831	0.795
		20			0.916	0.980	0.844	0.808
		10		0.967	0.930	0.893	0.857	0.820
		5	0.995	0.976	0.939	0.902	0.865	0.828
		0	1.000	0.981	0.944	0.907	0.870	0.832
	Outdoor Upper than Indoor	-5	1.000	0.981	0.944	0.907	0.870	0.832
		-10		0.981	0.944	0.907	0.870	0.832
		-20			0.944	0.907	0.870	0.832
-30					0.907	0.870	0.832	
Heating			5	10	20	30	40	50
Height difference H (m)	Indoor Upper than Outdoor	30				0.953	0.934	0.916
		20			0.972	0.953	0.934	0.916
		10		0.991	0.972	0.953	0.934	0.916
		5	1.000	0.991	0.972	0.953	0.934	0.916
		0	1.000	0.991	0.972	0.953	0.934	0.916
	Outdoor Upper than Indoor	-5	0.992	0.983	0.964	0.945	0.927	0.908
		-10		0.975	0.956	0.938	0.919	0.901
		-20			0.949	0.930	0.912	0.894
-30					0.923	0.905	0.887	

Note: model 42QSM048VT/38QSM048VT currently can't apply the long piping over 30 meters.

Model	60k		Pipe Length (m)					
Cooling			5	10	20	30	40	50
Height difference H (m)	Indoor Upper than Outdoor	30				0.851	0.808	0.766
		20			0.906	0.864	0.821	0.778
		10		0.963	0.920	0.877	0.833	0.790
		5	0.995	0.973	0.929	0.886	0.842	0.798
		0	1.000	0.978	0.934	0.890	0.846	0.802
	Outdoor Upper than Indoor	-5	1.000	0.978	0.934	0.890	0.846	0.802
		-10		0.978	0.934	0.890	0.846	0.802
		-20			0.934	0.890	0.846	0.802
-30					0.890	0.846	0.802	
Heating			5	10	20	30	40	50
Height difference H (m)	Indoor Upper than Outdoor	30				0.950	0.930	0.910
		20			0.970	0.950	0.930	0.910
		10		0.990	0.970	0.950	0.930	0.910
		5	1.000	0.990	0.970	0.950	0.930	0.910
		0	1.000	0.990	0.970	0.950	0.930	0.910
	Outdoor Upper than Indoor	-5	0.992	0.982	0.962	0.942	0.922	0.902
		-10		0.974	0.954	0.935	0.915	0.895
		-20			0.947	0.927	0.907	0.888
-30					0.920	0.900	0.881	

Note: model 42QSM060VT/38QSM060VT currently can't apply the long piping over 30 meters.

## 8. Noise Criterion Curves

### 8.1 Indoor Unit

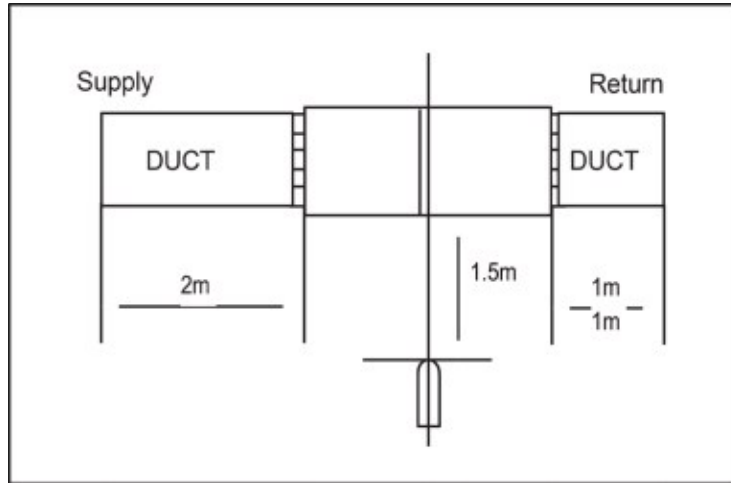

Notes:

- Sound measured at 1.5m away from the center of the unit.
- Data is valid at free field condition
- Data is valid at nominal operation condition
- Reference acoustic pressure  $O_{dB} = 20\mu Pa$
- Sound level will vary depending on a range of factors such as the construction -(acoustic absorption coefficient) of particular room in which the equipment is installed.
- The operating conditions are assumed to be standard.

18k

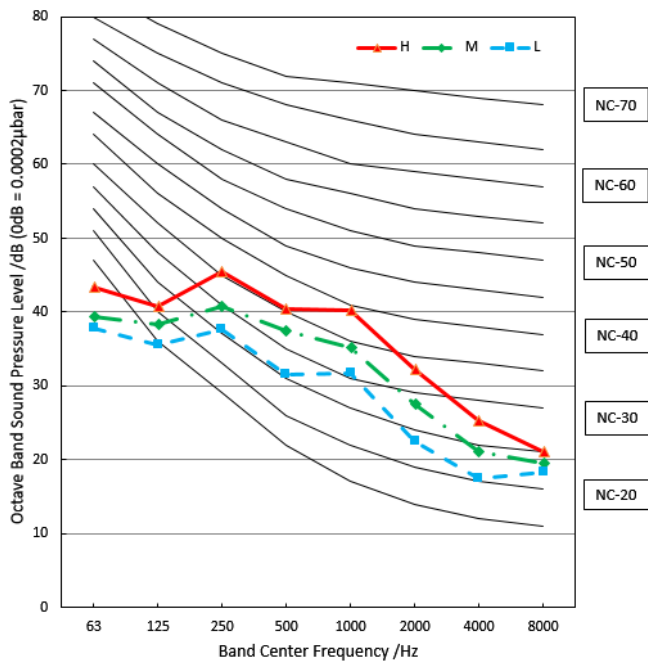

24k

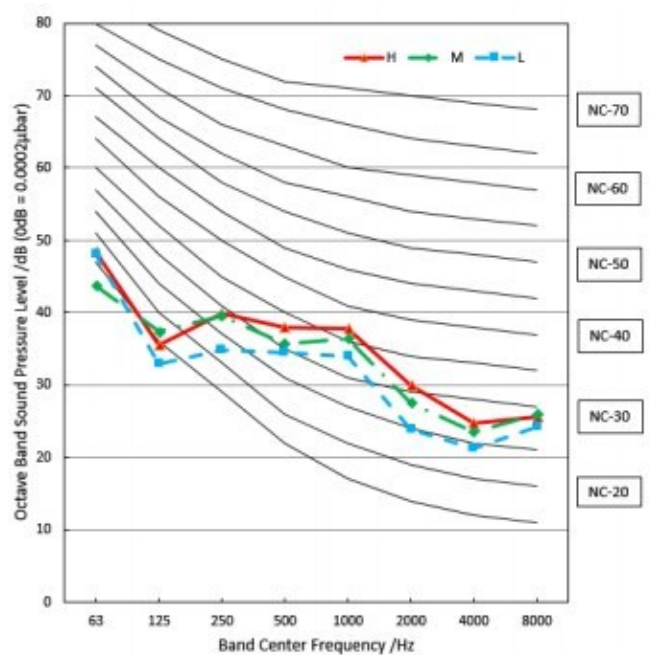

30k

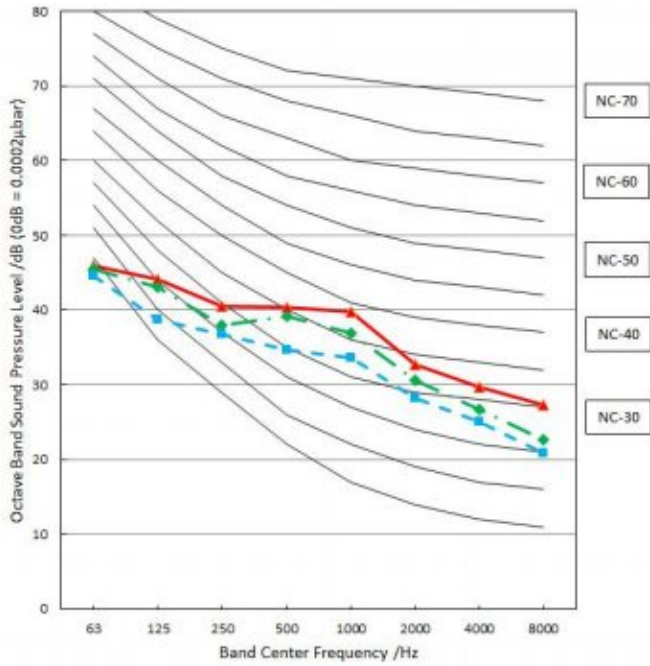

36k

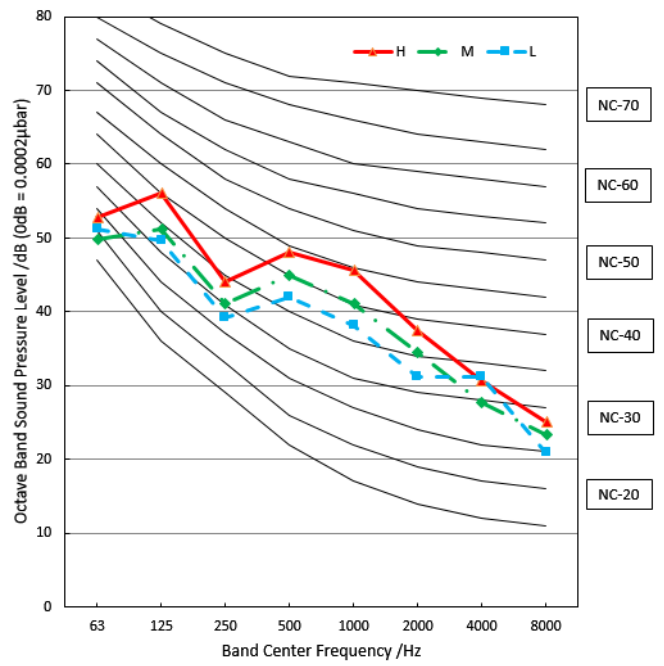

48k

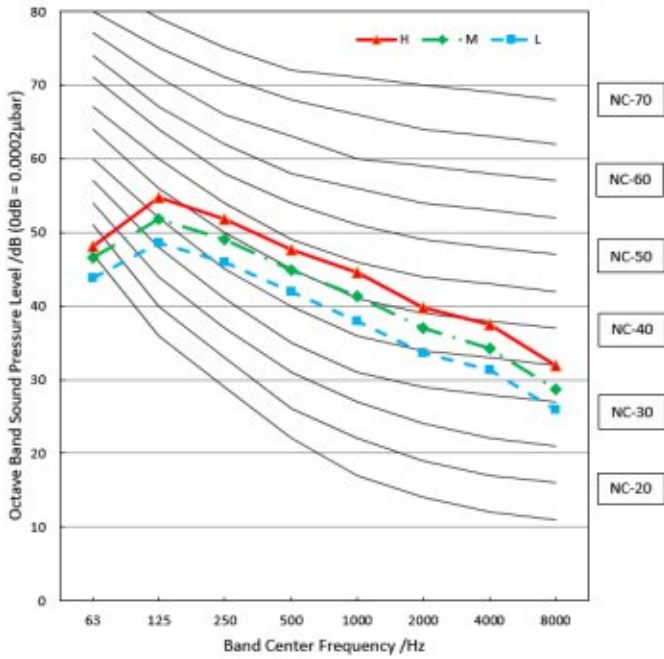

60k

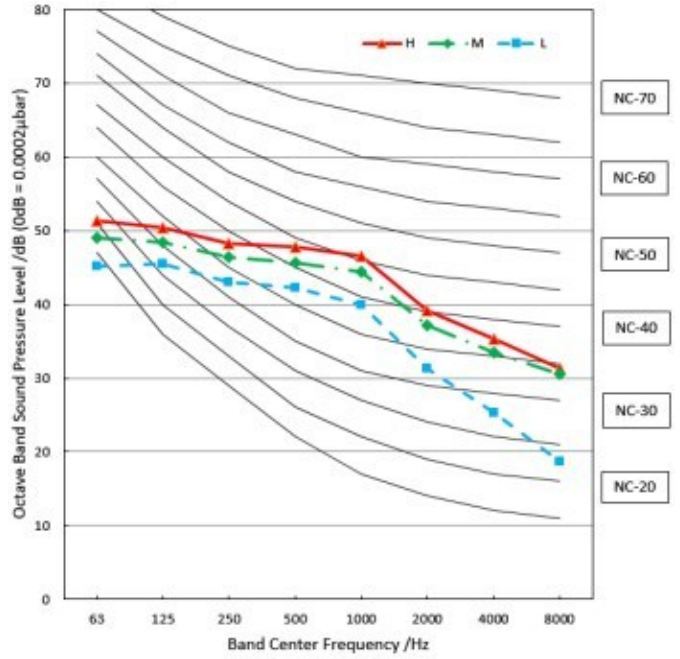

## 8.2 Outdoor Unit

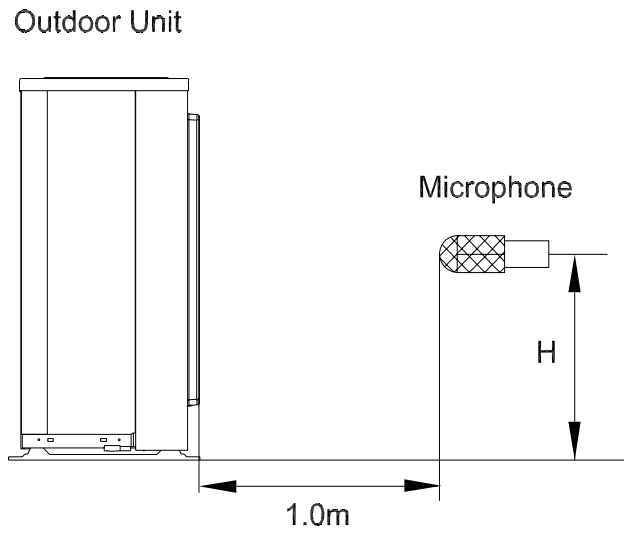

Note:  $H = 0.5 \times$  height of outdoor unit

Notes:

- Sound measured at 1.0m away from the center of the unit.
- Data is valid at free field condition
- Data is valid at nominal operation condition
- Reference acoustic pressure  $OdB=20\mu Pa$
- Sound level will vary depending on arrange off actors such as the construction (acoustic absorption coefficient) of particular room in which the equipment is installed.
- The operating conditions are assumed to be standard.

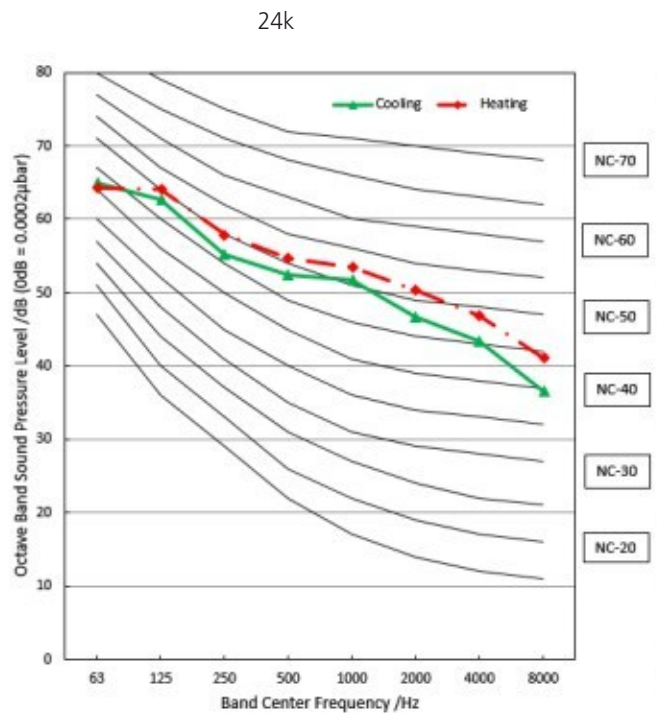
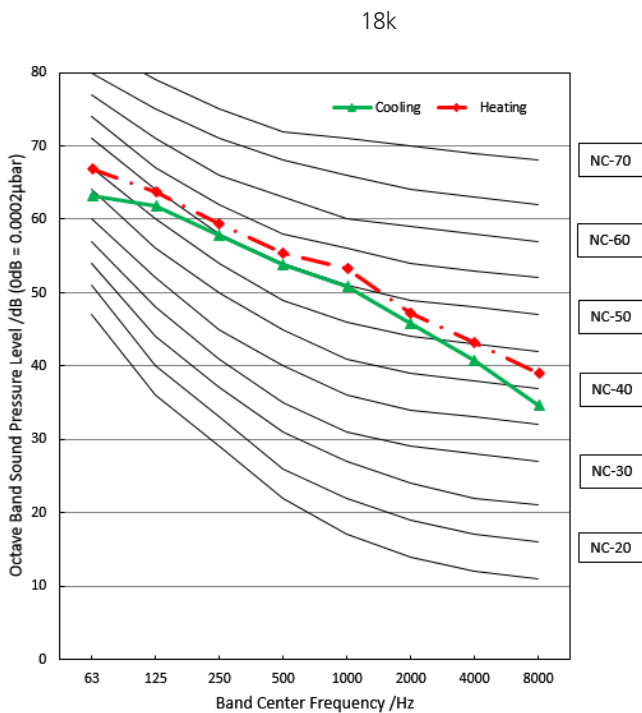

30k

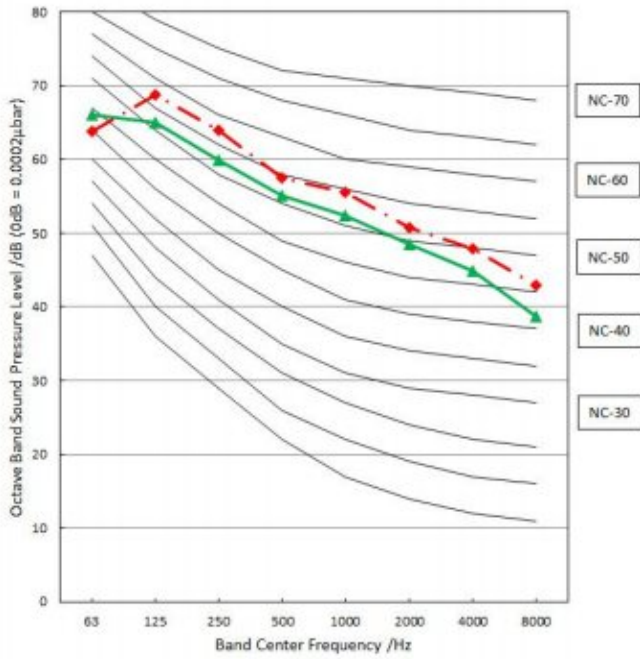

36k

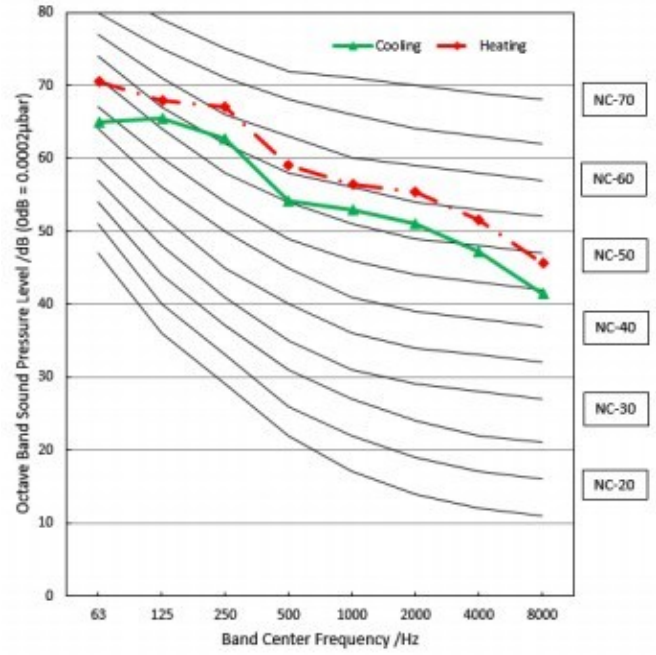

48k

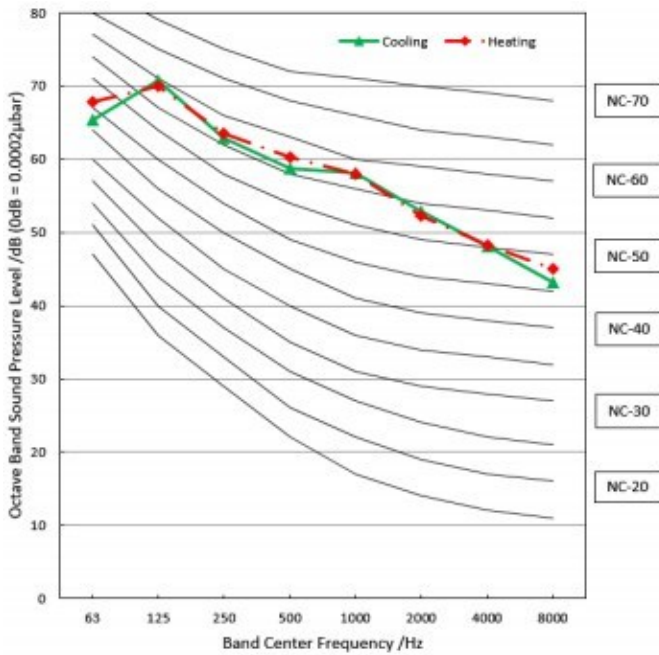

60k

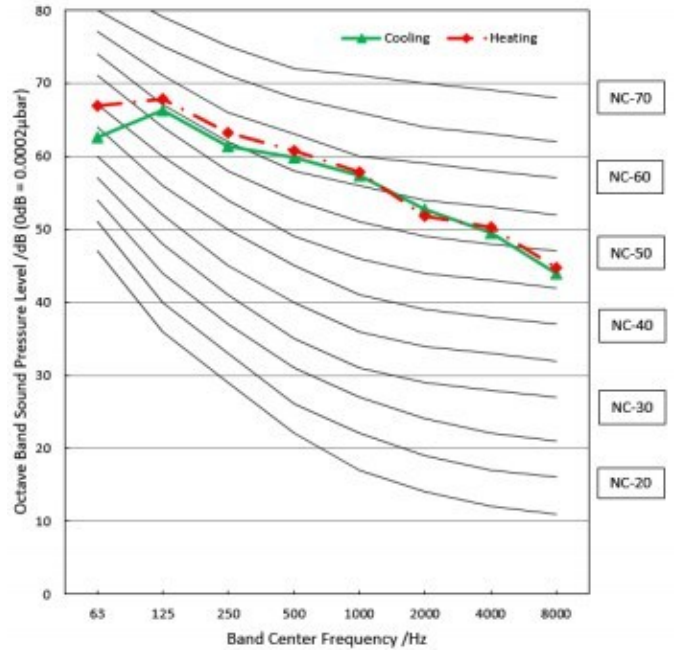

## 9. Electrical Characteristics

Capacity (Btu/h)		18k	24k	30k	36k	48k~60k
OUDOOR UNIT POWER	Phase	1-phase	1-phase	1-phase	1-phase	3-phase
	Frequency and Voltage	220-240V, 50/60Hz	220-240V, 50/60Hz	220-240V, 50/60Hz	220-240V, 50/60Hz	380-415V, 50/60Hz
	Power Wiring (mm <sup>2</sup> )	3×2.5	3×2.5	3×2.5	3×4.0	5×2.5
	Circuit Breaker/ Fuse (A)	25/20	25/20	40/30	40/30	32/25
Indoor/Outdoor Connecting Wiring	Weak Electric Signal)(mm <sup>2</sup> )	/	/	/	/	/
	Strong Electric Signal)(mm <sup>2</sup> )	4×1.0	4×1.0	4×1.0	4×1.0	4×1.0

# 10. Static Pressure

18k

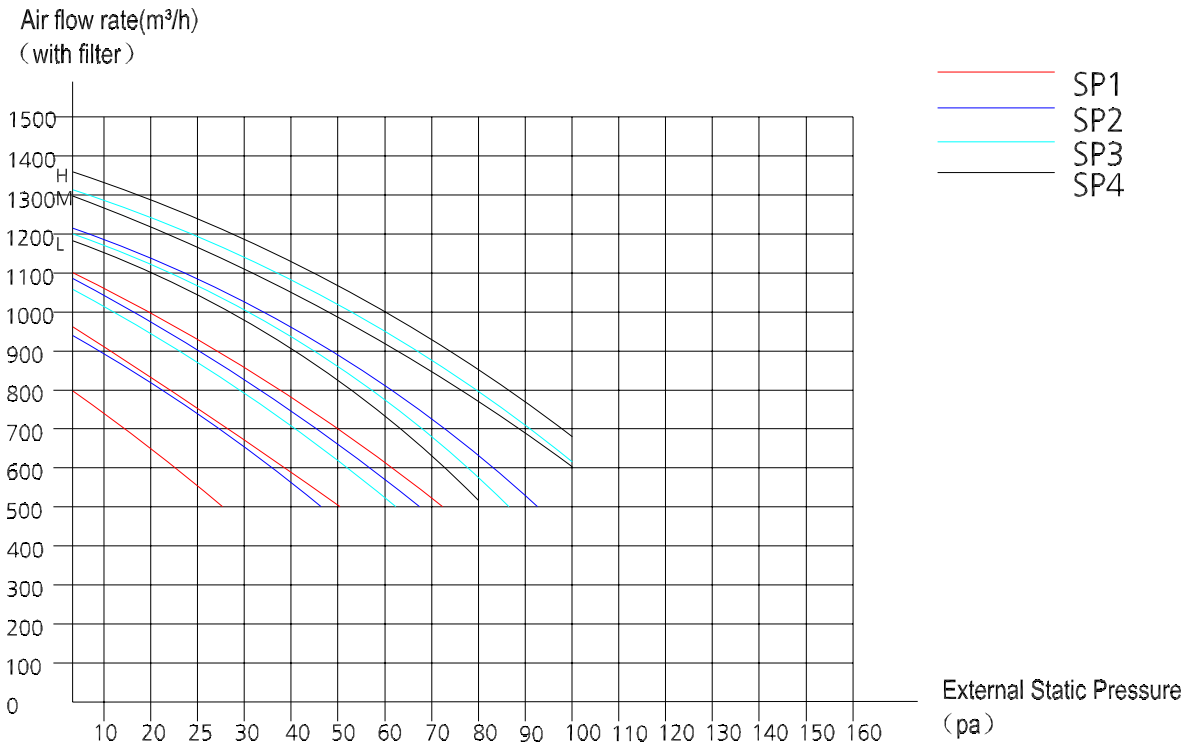

Constant air volume

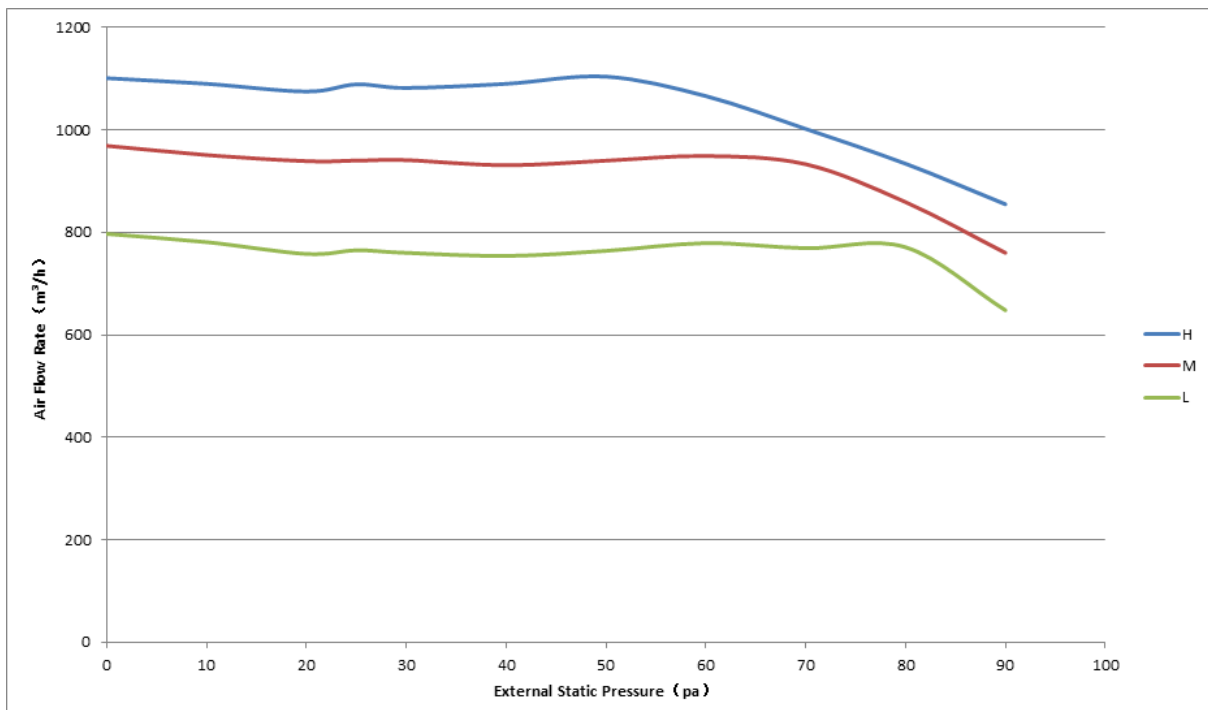

Air flow rate(m<sup>3</sup>/h)  
(with filter)

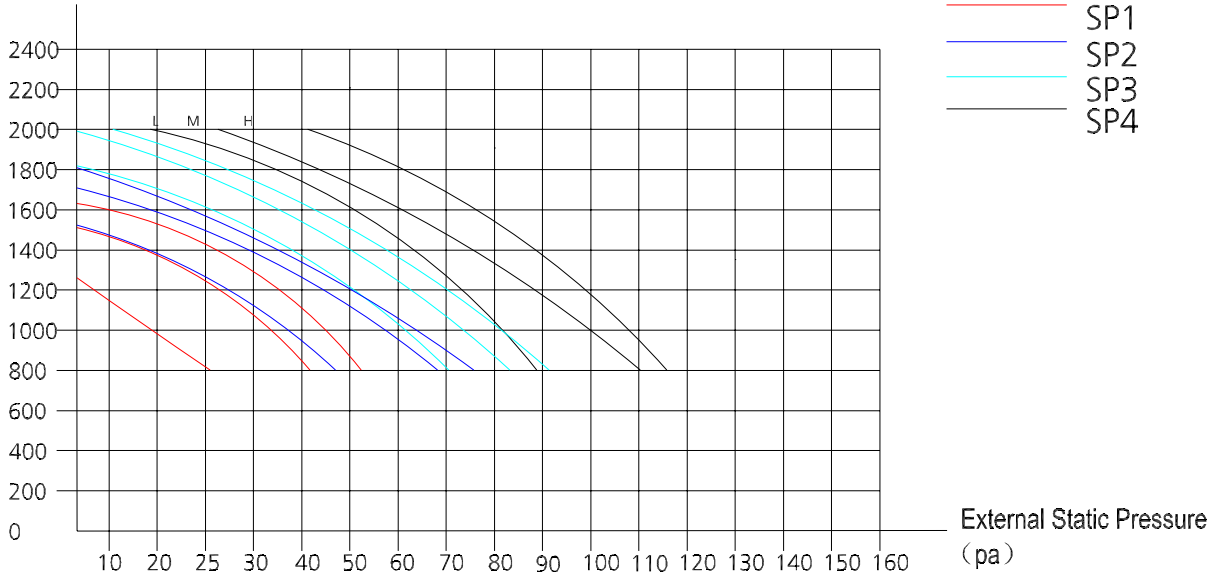

Constant air volume

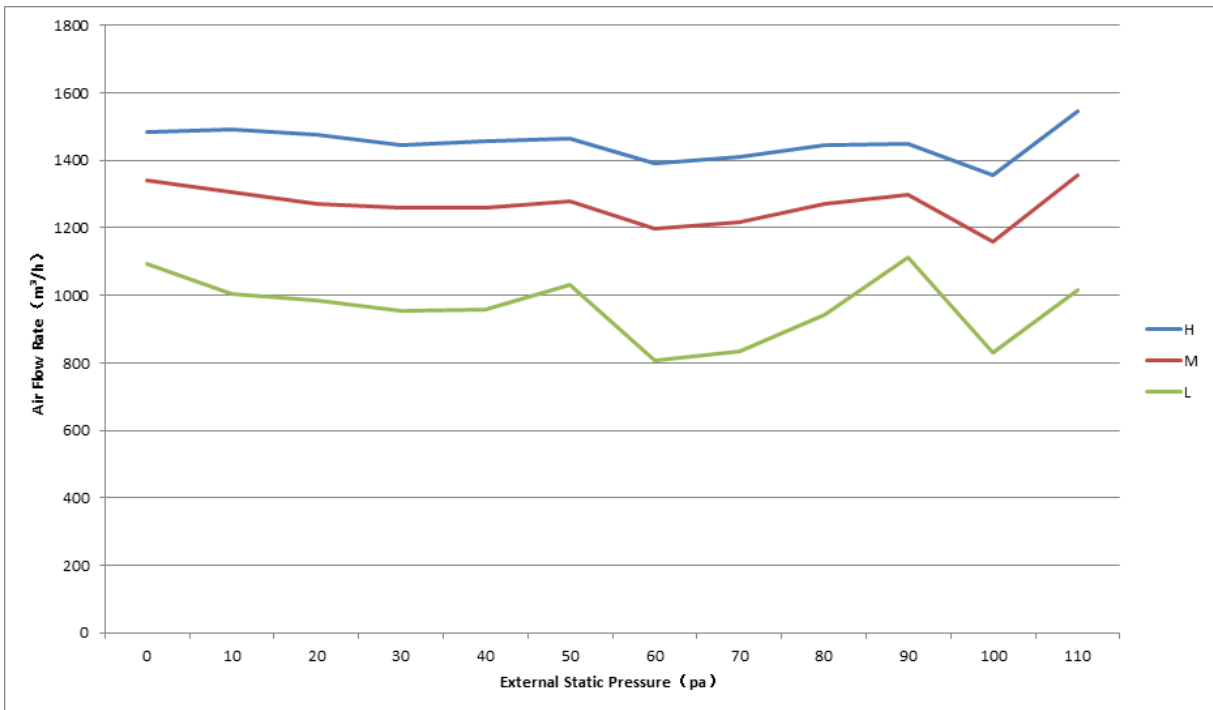

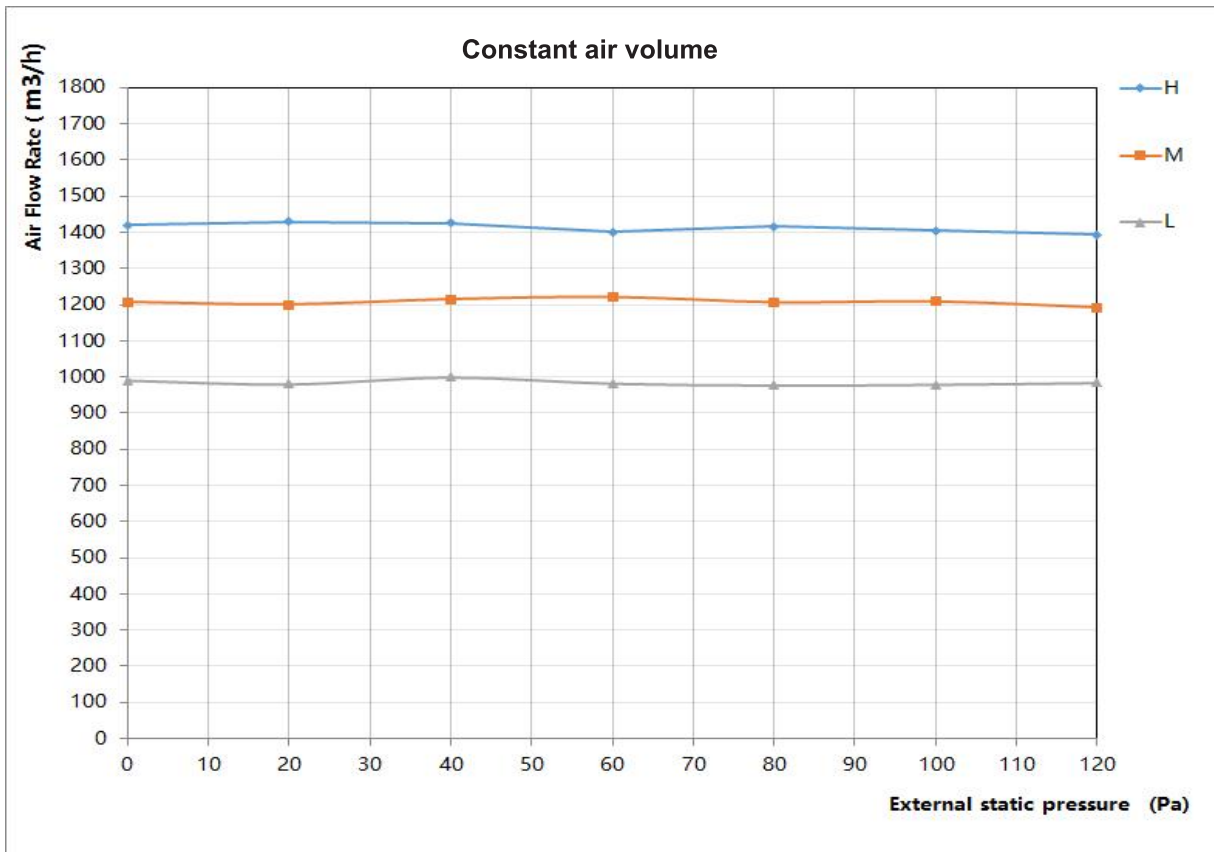
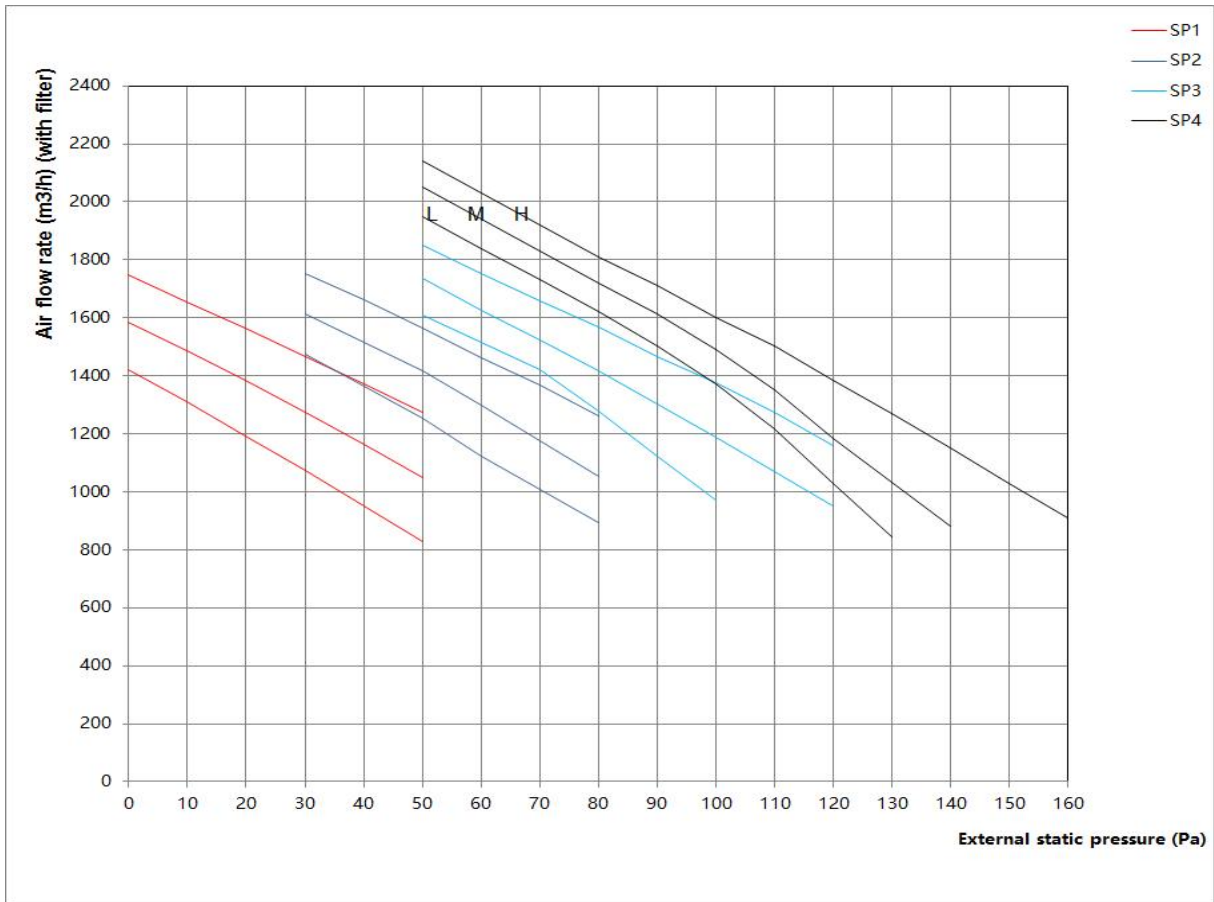

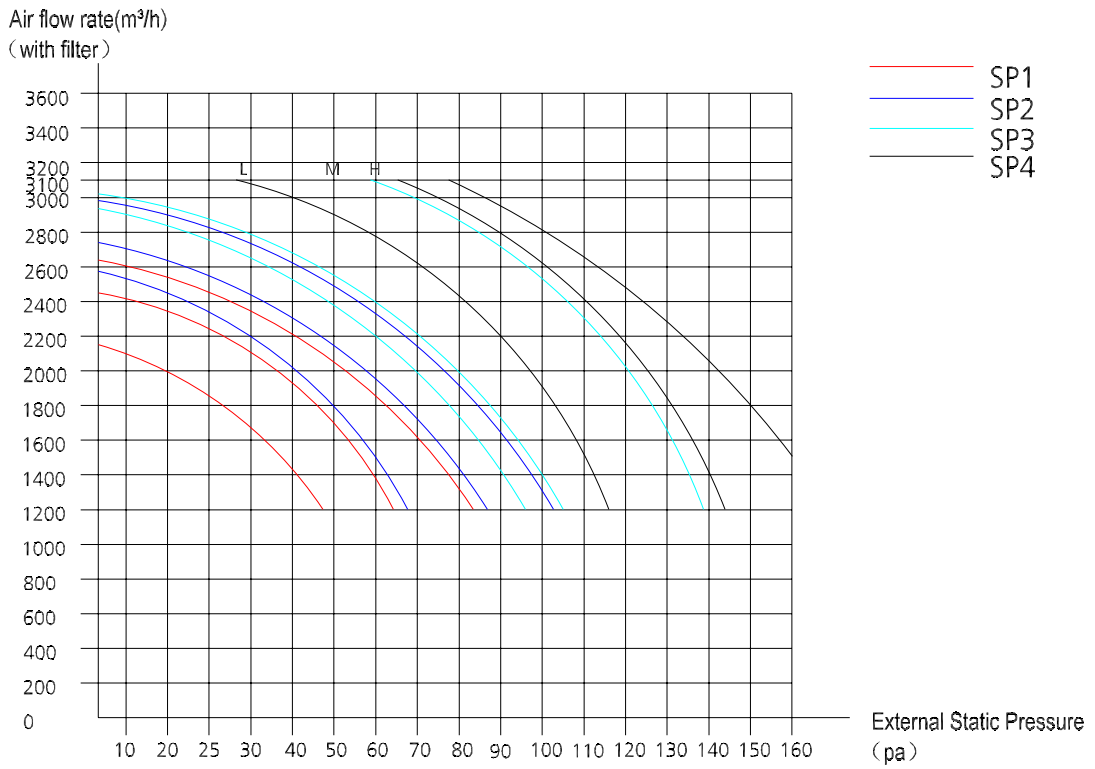

Constant air volume

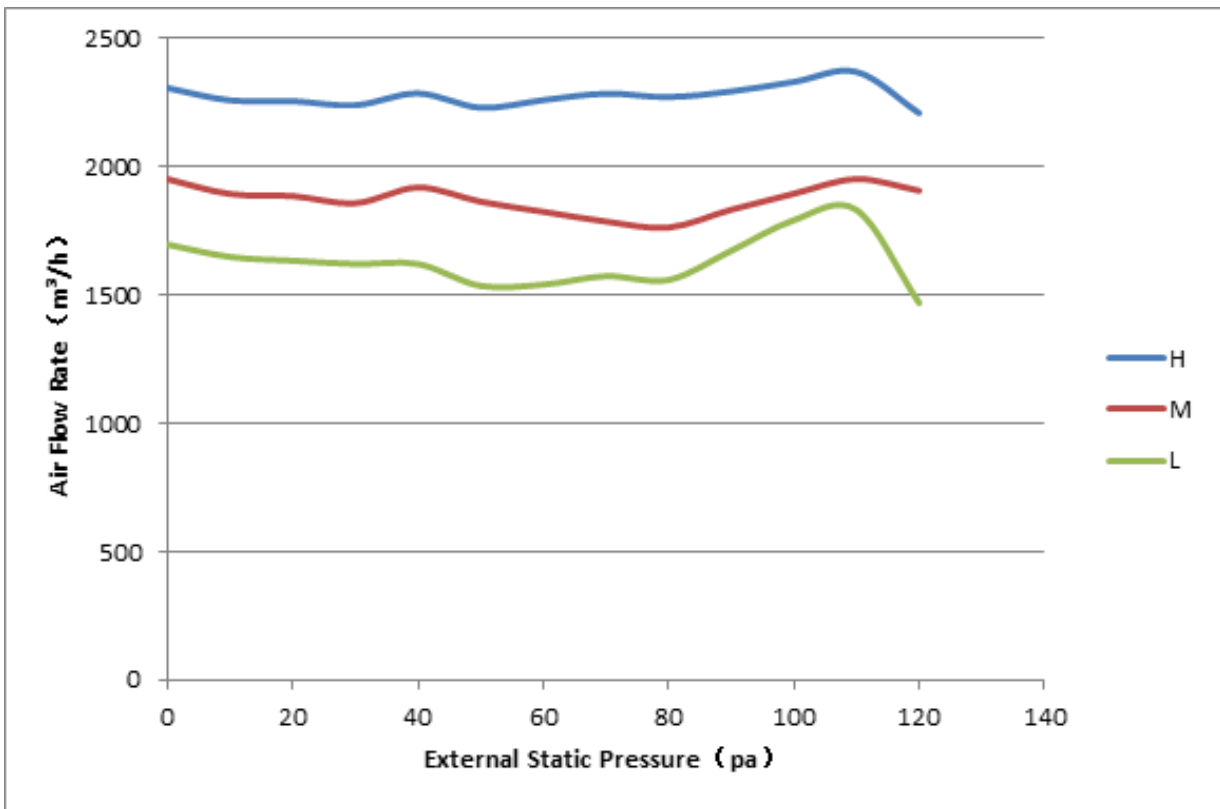

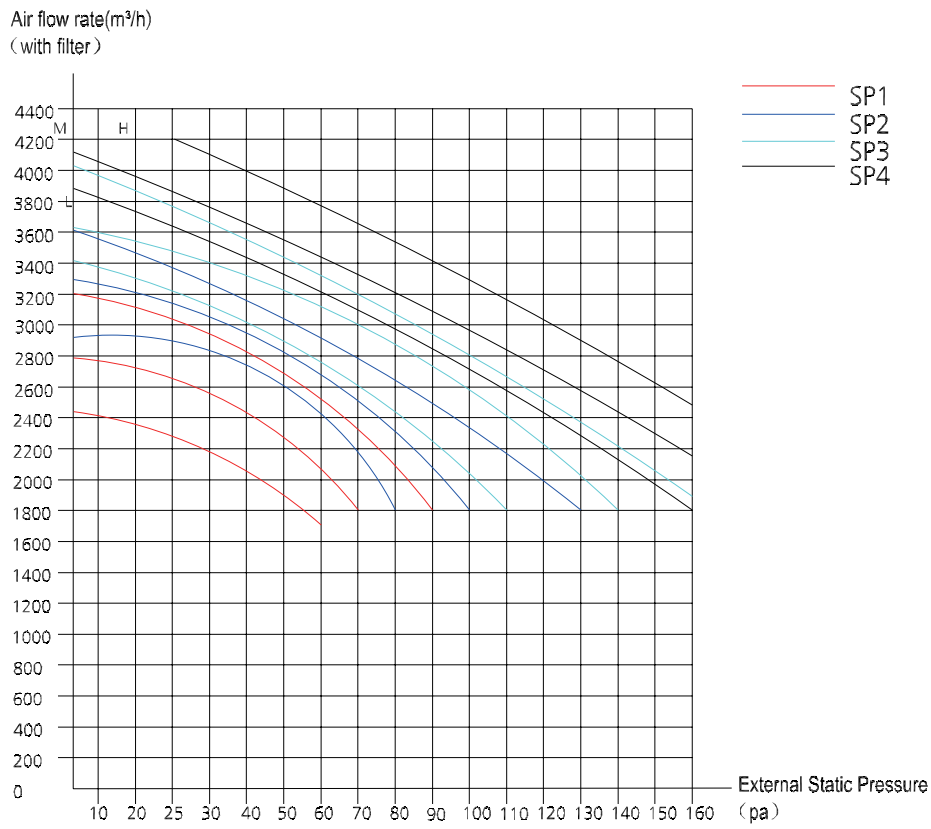

Constant air volume

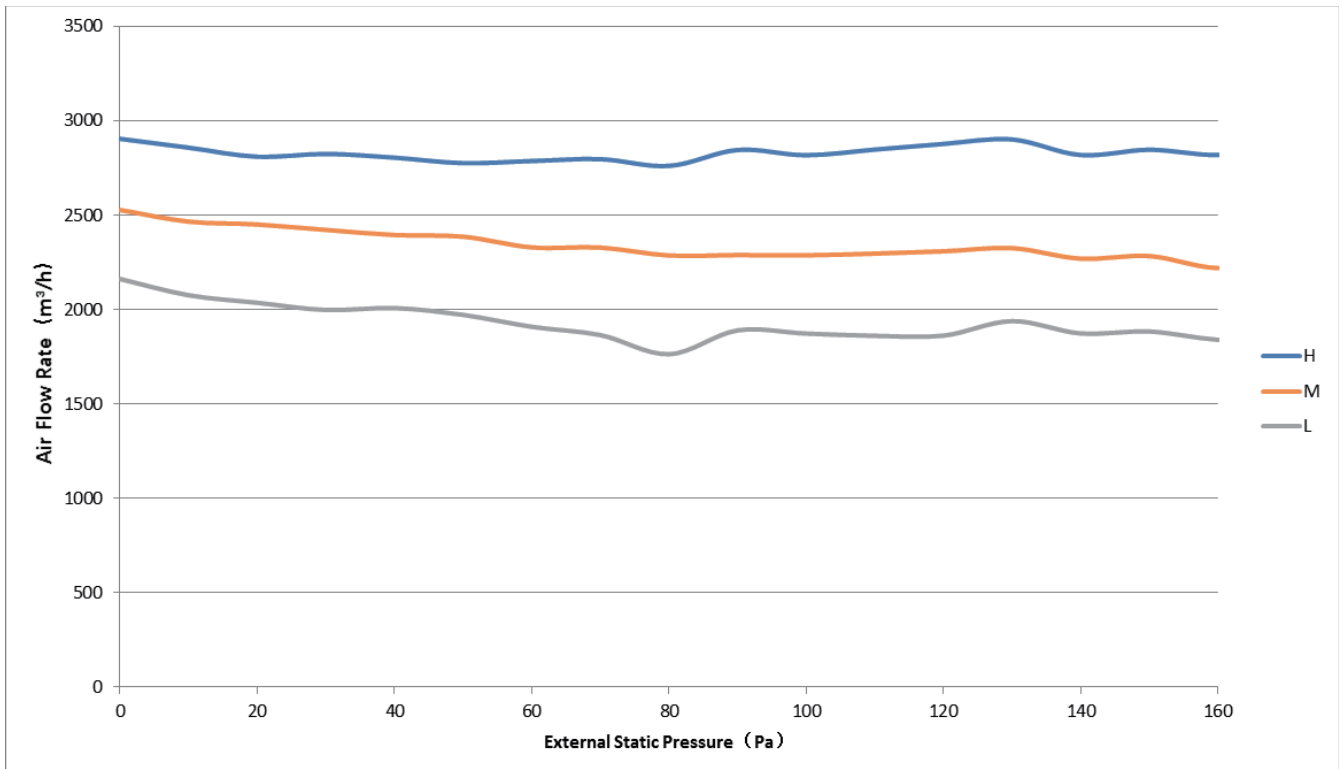

60k

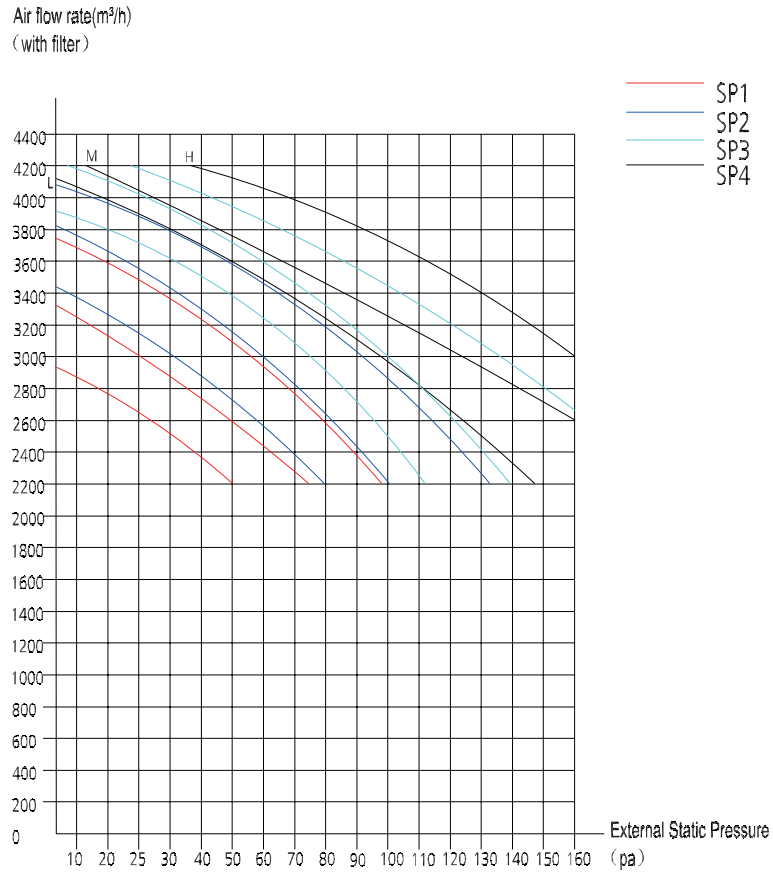

Constant air volume

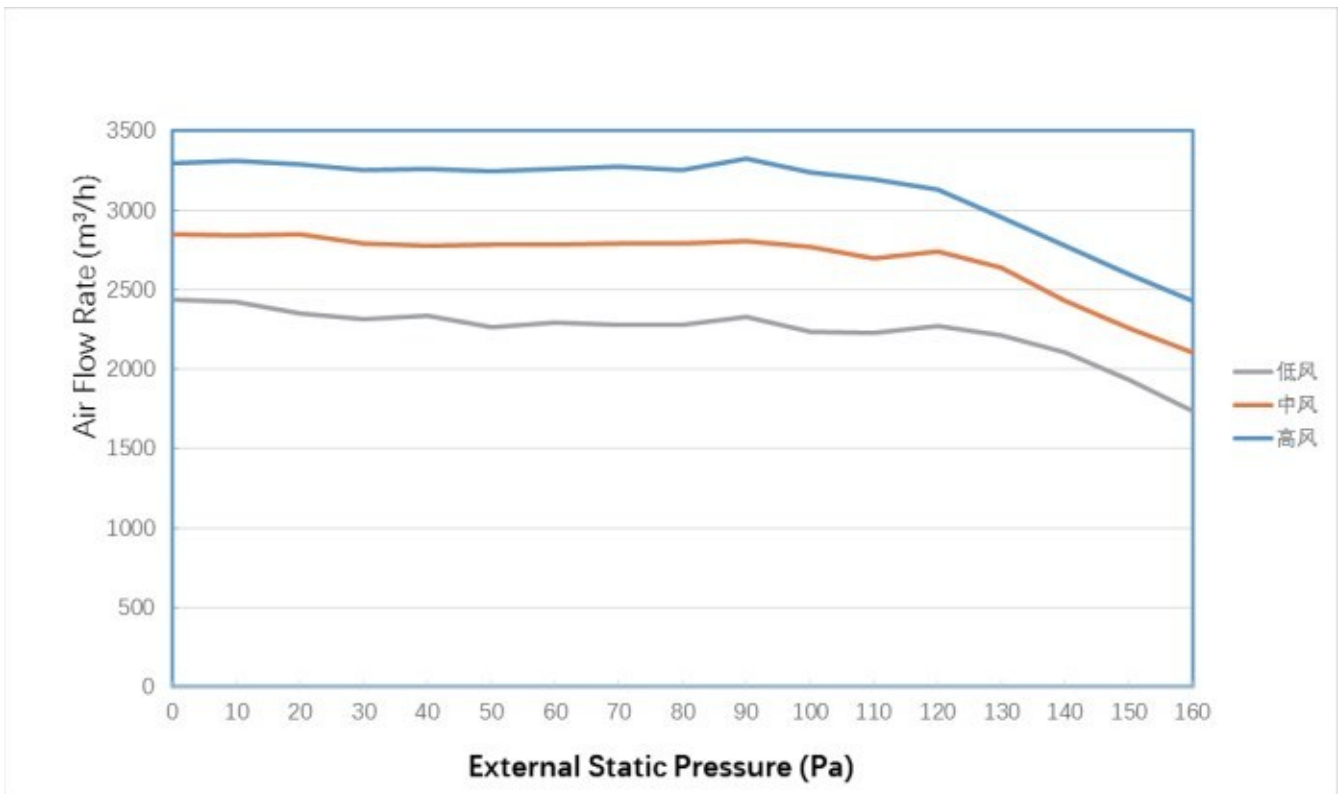

---

# Product Features

## Contents

<b>1.</b>	<b>Operation Modes and Functions .....</b>	<b>60</b>
1.1	Abbreviations .....	60
1.2	Safety Features .....	60
1.3	Display Function .....	60
1.4	Fan.....	60
1.5	Cooling Mode .....	61
1.6	Heating Mode (Heat pump models).....	62
1.7	Auto Mode.....	63
1.8	Drying Mode .....	63
1.9	Forced Operation Function .....	63
1.10	Timer Function .....	63
1.11	ECO Function .....	64
1.12	Auto-Restart.....	64
1.13	8°C Heating(Optional) .....	64
1.14	Self clean(Optional) .....	64
1.15	Follow Me(Optional).....	64
1.16	Silence(Optional) .....	64
<b>2.</b>	<b>Remote Controller Functions .....</b>	<b>65</b>
2.1	LCD Wired Remote Controller .....	65
2.2	Centralized Controller .....	68
2.3	Using the wire controller to set external static pressure .....	69
2.4	Using the wire controller to set airflow rate .....	69

# 1. Operation Modes and Functions

## 1.1 Abbreviation

Unit element abbreviations

Abbreviation	Element
T1	Indoor room temperature
T2	Coil temperature of evaporator
T3	Coil temperature of condenser
T4	Outdoor ambient temperature
TP	Compressor discharge temperature
Tsc	Adjusted setting temperature

In this manual, such as CDIFTEMP, HDIFTEMP2, TCE1, TCE2...etc., they are well-setting parameter of EEPROM.

## 1.2 Safety Features

### Compressor three-minute delay at restart

Compressor functions are delayed for up to ten seconds upon the first startup of the unit, and are delayed for up to three minutes upon subsequent unit restarts.

### Automatic shutoff based on discharge temperature

If the compressor discharge temperature exceeds a certain level for nine seconds, the compressor ceases operation.

### Automatic shutoff based on fan speed

If a fault occurs on the air volume regulator or the regulator enters protection mode, it sends the error message CF and an instruction to reduce fan speed to the master. The message and the instruction can be inquired with the remote controller or the wired controller. (Fault and protection information are displayed for one minute). After a fault occurs, the master unit shows the error code E3 and the fault count for one minute. If the fault occurs three times, then the fan is unable to resolve the problem independently. External shutdown by a remote controller, wired controller, or central controller must be used to clear the fan fault and fault count. The fan runs normally for 5 minutes while clearing fault count.

0	No malfunction
1	P0 Overcurrent
2	Overpressure
3	Overload
4	Over speed
5	Startup malfunction
6	Lack of phase

7	DC voltage too low
8	Communication fault
9	Parameter fault
10	L3 Current limited
11	L5 Voltage limited
12	Target speed cannot be met during the static pressure calculation process

### Inverter module protection

The inverter module has an automatic shutoff mechanism based on the unit's current, voltage, and temperature. If automatic shutoff is initiated, the corresponding error code is displayed on the indoor unit and the unit ceases operation.

### Indoor fan delayed operation

- When the unit starts, the louver is automatically activated and the indoor fan will operate after a period of setting time or the louver is in place.
- If the unit is in heating mode, the indoor fan is regulated by the anti-cold wind function.

### Compressor preheating

Preheating is automatically activated when T4 sensor is lower than setting temperature.

### Sensor redundancy and automatic shutoff

- If one temperature sensor malfunctions, the air conditioner continues operation and displays the corresponding error code, allowing for emergency use.
- When more than one temperature sensor is malfunctioning, the air conditioner ceases operation.

## 1.3 Display Function

Unit display functions

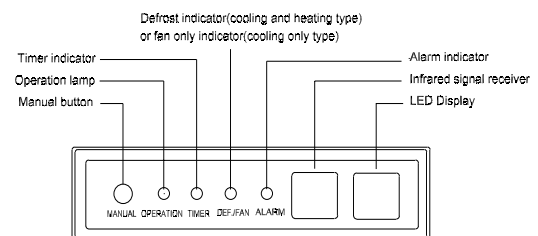

## 1.4 Fan Mode

When fan mode is activated:

- The outdoor fan and compressor are stopped.
- Temperature control is disabled and no temperature

setting is displayed.

- The indoor fan speed can be set to 1%~100%, or low, medium, high and auto.
- The louver operations are identical to those in cooling mode.
- Auto fan: In fan-only mode, AC operates the same as auto fan in cooling mode with the temperature set at 24°C.

## 1.5 Cooling Mode

### 1.5.1 Compressor Control

Reach the configured temperature:

- 1) When the compressor runs continuously for less than 120 minutes.
  - If the following conditions are satisfied, the compressor ceases operation.
    - Calculated frequency(fb) is less than minimum limit frequency(FminC).
    - Compressor runs at FminC more than ten minutes.
    - T1 is lower than or equal to (Tsc-CDIFTEMP-0.5°C)
- 2) When the compressor runs continuously for more than 120 minutes.
  - If the following conditions are satisfied, the compressor ceases operation.
    - Calculated frequency(fb) is less than minimum limit frequency(FminC).
    - Compressor runs at FminC more than 10 minutes.
    - When T1 is lower than or equal to (Tsc-CDIFTEMP).
- 3) If one of the following conditions is satisfied, not judge protective time.
  - Compressor running frequency is more than test frequency.
  - When compressor running frequency is equal to test frequency, T4 is more than 15°C or T4 fault.
  - Change setting temperature.
  - Turbo or sleep function on/off
  - Various frequency limit shutdown occurs.

### 1.5.2 Indoor Fan Control

- 1) In cooling mode, the indoor fan operates continuously. The fan speed can be set to 1%-100%, or low, medium, high and auto.
- 2) Auto fan action in cooling mode:
  - Descent curve
    - When T1-Tsc is lower than or equal to 3.5°C, fan speed reduces to 80%;
    - When T1-Tsc is lower than or equal to 1°C, fan speed reduces to 60%;

- When T1-Tsc is lower than or equal to 0.5°C, fan speed reduces to 40%;
- When T1-Tsc is lower than or equal to 0°C, fan speed reduces to 20%;
- When T1-Tsc is lower than or equal to -0.5°C, fan speed reduces to 1%.
- Rise curve
  - When T1-Tsc is higher than 0°C, fan speed increases to 20%;
  - When T1-Tsc is higher than 0.5°C, fan speed increases to 40%;
  - When T1-Tsc is higher than 1°C, fan speed increases to 60%;
  - When T1-Tsc is higher than 1.5°C, fan speed increases to 80%;
  - When T1-Tsc is higher than 4°C, fan speed increases to 100%.

### 1.5.3 Outdoor Fan Control

- The outdoor unit will be run at different fan speed according to T4 and compressor frequency.
- For different outdoor units, the fan speeds are different.

### 1.5.4 Condenser Temperature Protection

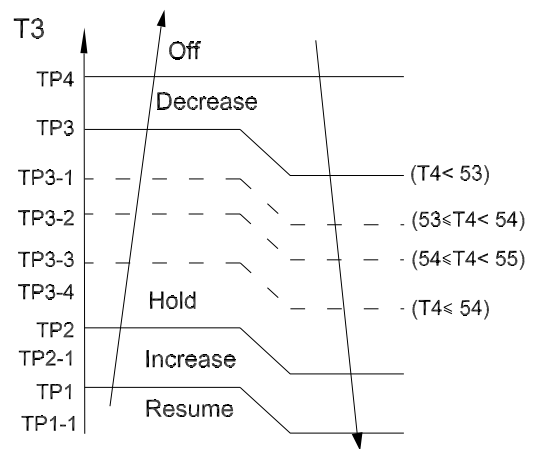

When the condenser temperature exceeds a configured value, the compressor ceases operation.

### 1.5.5 Evaporator Temperature Protection

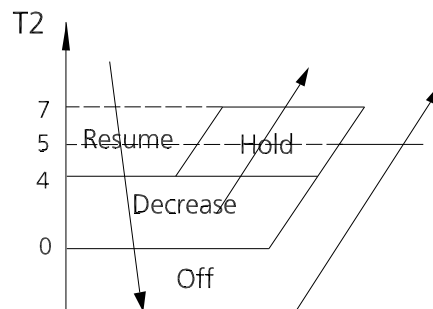

- Off: Compressor stops.
- Decrease: Decrease the running frequency to the lower level per 1 minute.
- Hold: Keep the current frequency.
- Resume: No limitation for frequency.

## 1.6 Heating Mode(Heat Pump Units)

### 1.6.1 Compressor Control

- 1) Reach the configured temperature
  - If the following conditions are satisfied, the compressor ceases operation.
    - Calculated frequency(fb) is less than minimum limit frequency(FminH).
    - Compressor runs at FminH more than 10 minutes.
    - T1 is higher than or equal to Tsc+ HDIFTEMP2.

Note: HDIFTEMP2 is EEPROM setting parameter. It is 2°C usually.

- 2) When the current is higher than the predefined safe value, surge protection is activated, causing the compressor to cease operations.
  - If one of the following conditions is satisfied, not judge protective time.
    - Compressor running frequency is more than test frequency.
    - Compressor running frequency is equal to test frequency, T4 is more than 15°C or T4 fault.
    - Change setting temperature.
    - Turbo or sleep function on/off.

### 1.6.2 Indoor Fan Control

- 1) In heating mode, the indoor fan operates continuously. The fan speed can be set to 1%-100%, or low, medium, high and auto.
  - Anti-cold air function
    - The indoor fan is controlled by the indoor temperature T1 and indoor unit coil temperature T2.

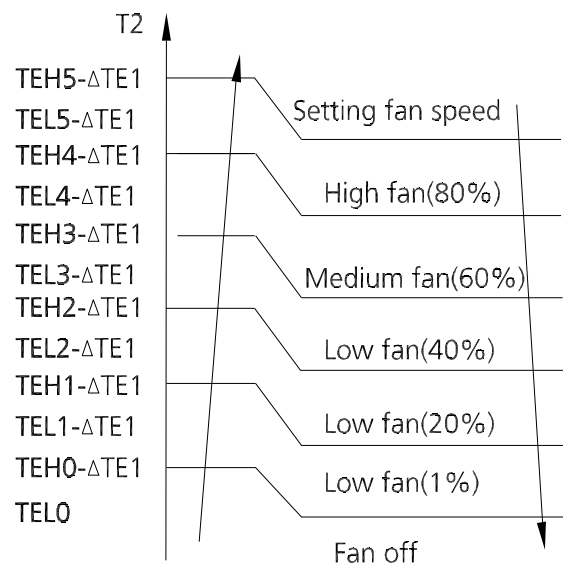

$\Delta TE1=0$

- 2) Auto fan action in heating mode:
  - Rise curve
    - When T1-Tsc is higher than -1.5°C, fan speed reduces to 80%;
    - When T1-Tsc is higher than 0°C, fan speed reduces to 60%;
    - When T1-Tsc is higher than 0.5°C, fan speed reduces to 40%;
    - When T1-Tsc is higher than 1°C, fan speed reduces to 20%.
  - Descent curve
    - When T1-Tsc is lower than or equal to 0.5°C, fan speed increases to 20%;
    - When T1-Tsc is lower than or equal to 0°C, fan speed increases to 60%;
    - When T1-Tsc is lower than or equal to -1.5°C, fan speed increases to 80%;
    - When T1-Tsc is lower than or equal to -3°C, fan speed increases to 100%.

### 1.6.3 Outdoor Fan Control

- The outdoor unit will be run at different fan speed according to T4 and compressor frequency.
- For different outdoor units, the fan speeds are different.

### 1.6.4 Defrosting mode

- The unit enters defrosting mode according to the temperature value of T3 and T4 as well as the compressor running time.
- In defrosting mode, the compressor continues to run, the indoor and outdoor motor will cease operation, the defrost light of the indoor unit will turn on, and the "df" symbol is displayed.

- If any one of the following conditions is satisfied, defrosting ends and the machine switches to normal heating mode:
  - T3 rises above TCDE1.
  - T3 maintained above TCDE2 for 80 seconds.
  - Unit runs for 15 minutes consecutively in defrosting mode.
- If T4 is lower than or equal to  $-22^{\circ}\text{C}$  and compressor running time is more than TIMING\_DEFROST\_TIME, if any one of the following conditions is satisfied, defrosting ends and the machine switches to normal heating mode:
  - Unit runs for 10 minutes consecutively in defrosting mode.
  - T3 rises above  $10^{\circ}\text{C}$ .

For some models:

- T3 is lower than  $3^{\circ}\text{C}$  ( $37.4^{\circ}\text{F}$ ) and compressor running time is more than 120 minutes, at this time, if T3 is lower than  $\text{TCDI1}+4^{\circ}\text{C}$  ( $39.2^{\circ}\text{F}$ ) for 3 minutes, the unit enters defrosting mode. If any one of the following conditions is satisfied, defrosting ends and the machine switches to normal heating mode:
  - T3 rises above  $\text{TCDE1}+4^{\circ}\text{C}$ .
  - T3 maintained above  $\text{TCDE2}+4^{\circ}\text{C}$  for 80 seconds.
  - Unit runs for 15 minutes consecutively in defrosting mode.

### 1.6.5 Evaporator Coil Temperature Protection

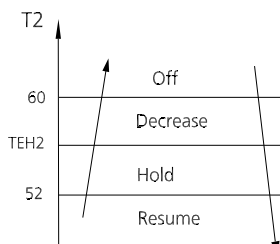

- Off: Compressor stops.
- Decrease: Decrease the running frequency to the lower level per 20 seconds.
- Hold: Keep the current frequency.
- Resume: No limitation for frequency.

### 1.7 Auto-mode

- This mode can be selected with the remote controller and the temperature setting can be adjusted between  $16^{\circ}\text{C}\sim 30^{\circ}\text{C}$ .
- In auto mode, the machine selects cooling, heating, or fan-only mode on the basis of  $\Delta T$  ( $\Delta T = T1 - T5$ ).

$\Delta T$	Running mode
$\Delta T > 2^{\circ}\text{C}$ ( $3.6^{\circ}\text{F}$ )	Cooling
$-3^{\circ}\text{C}$ ( $-5.4^{\circ}\text{F}$ ) $\leq \Delta T \leq 2^{\circ}\text{C}$ ( $3.6^{\circ}\text{F}$ )	Fan-only
$\Delta T < -3^{\circ}\text{C}$ ( $-5.4^{\circ}\text{F}$ )	Heating*

Heating\*: In auto mode, cooling only models run the fan

- Indoor fan will run at auto fan speed.
- The louver operates same as in relevant mode.
- If the machine switches mode between heating and cooling, the compressor will keep stopping for certain time and then choose mode according to  $\Delta T$ .

### 1.8 Drying mode

- In drying mode, AC operates the same as auto fan in cooling mode.
- All protections are activated and operate the same as they do that in cooling mode.
- Low Room Temperature Protection

If the room temperature is lower than  $10^{\circ}\text{C}$ , the compressor ceases operations and does not resume until room temperature exceeds  $12^{\circ}\text{C}$ .

### 1.9 Forced operation function

Press the AUTO/COOL button, the AC will run as below sequence:

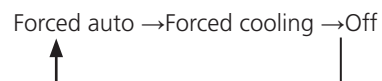

- Forced cooling mode:

The compressor and outdoor fan continue to run and the indoor fan runs at breeze speed. After running for 30 minutes, the AC will switch to auto mode with a preset temperature of  $24^{\circ}\text{C}$  ( $76^{\circ}\text{F}$ ).

- Forced auto mode:

Forced auto mode operates the same as normal auto mode with a preset temperature of  $24^{\circ}\text{C}$  ( $76^{\circ}\text{F}$ ).

- The unit exits forced operation when it receives the following signals:
  - Switch off
  - Changes in:
    - mode
    - fan speed
    - sleep mode
    - Follow me

### 1.10 Timer Function

- The timing range is 24 hours.
- Timer On. The machine turns on automatically at the preset time.

- **Timer Off.** The machine turns off automatically at the preset time.
- **Timer On/Off.** The machine turns on automatically at the preset On Time, and then turns off automatically at the preset Off Time.
- **Timer Off/On.** The machine turns off automatically at the preset Off Time and then turns on automatically at the preset On Time.
- The timer does not change the unit operation mode. If the unit is off now, it does not start up immediately after the "timer off" function is set. When the setting time is reached, the timer LED switches off and the unit running mode remains unchanged.
- The timer uses relative time, not clock time

### 1.11 ECO Function

- The ECO function is available in cooling, heating, or auto mode.
- The operational process for sleep mode is as follows:
  - When cooling, the temperature rises 1°C (to not higher than 30°C) every hour. After 2 hours, the temperature stops rising and the indoor fan is fixed at low speed.
  - When heating, the temperature decreases 1°C (to not lower than 17°C) every hour. After 2 hours, the temperature stops decreasing and the indoor fan is fixed at low speed. Anti-cold wind function takes priority.
- The operating time for sleep mode is 8 hours, after which, the unit exits this mode and does not switches off.

### 1.12 Auto-Restart function

- The indoor unit has an auto-restart module that allows the unit to restart automatically. The module automatically stores the current settings and in the case of a sudden power failure, will restore those setting automatically within 3 minutes after power returns.

### 1.13 8°C Heating(Optional)

In heating mode, the temperature can be set to as low as 8°C, preventing the indoor area from freezing if unoccupied during severe cold weather.

### 1.14 Self clean(Optional)

- If you press "Self Clean" when the unit is in cooling, drying, auto cooling or auto drying mode:
  - The indoor unit will run in low fan mode for a certain time, then ceases operation.

- Self Clean keeps the indoor unit dry and prevents mold growth.
- When match with multi outdoor unit, this function is disabled.

### 1.15 Follow me(Optional)

- If you press "Follow Me" on the remote, the indoor unit will beep. This indicates the follow me function is active.
- Once active, the remote control will send a signal every 3 minutes, with no beeps. The unit automatically sets the temperature according to the measurements from the remote control.
- The unit will only change modes if the information from the remote control makes it necessary, not from the unit's temperature setting.
- If the unit does not receive a signal for 7 minutes or you press "Follow Me," the function turns off. The unit regulates temperature based on its own sensor and settings.

### 1.16 Silence(Optional)

- Press "Silence" on the remote control to enable the SILENCE function. While this function is active, the compressor frequency is maintained at a lower level than F3. The indoor unit will run at faint breeze(1%), which reduces noise to the lowest possible level.
- When match with multi outdoor unit, this function is disabled.

## 2. Remote Controller Functions

### 2.1 LCD Wired Remote Controller

#### 2.1.1 LCD Wired Remote Controller KJR-12B/DP(T) (Standard)

The KJR-12B/DP(T) wired remote controller is standard for Duct type.

##### i) Buttons and Functions

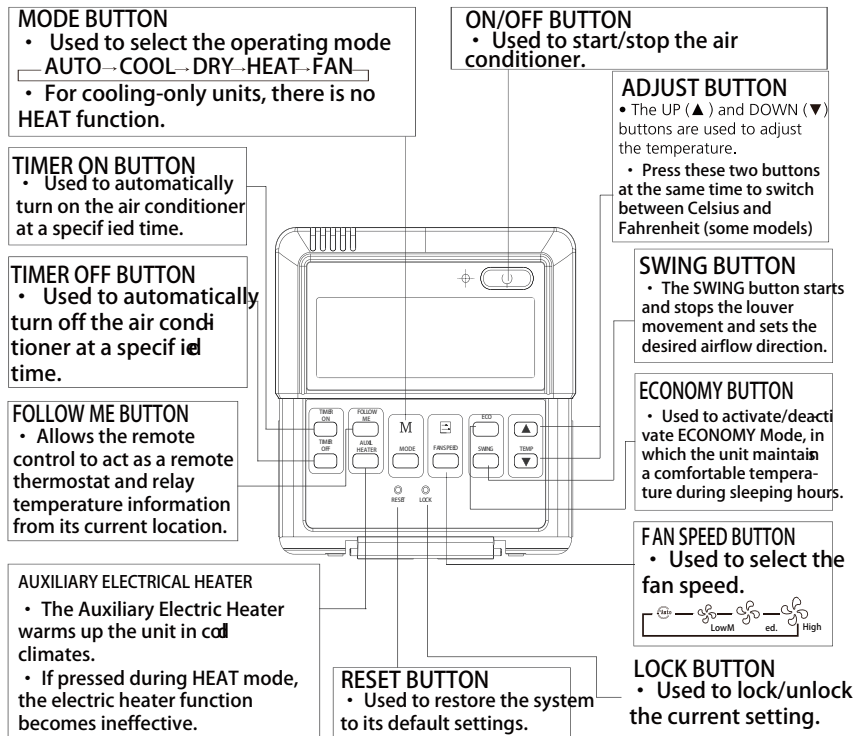

##### ii) LCD Screen

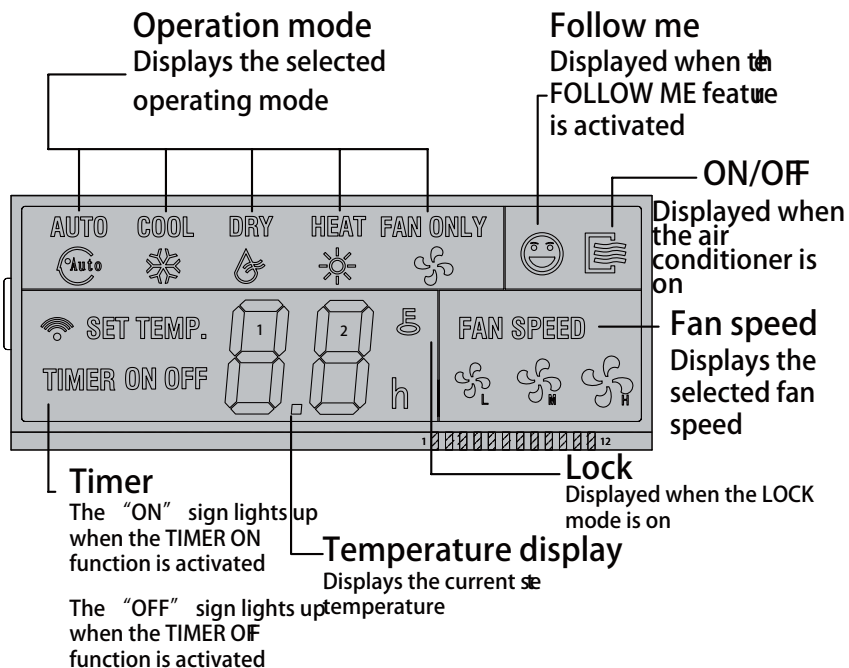

### iii) Installation

- Dimensions

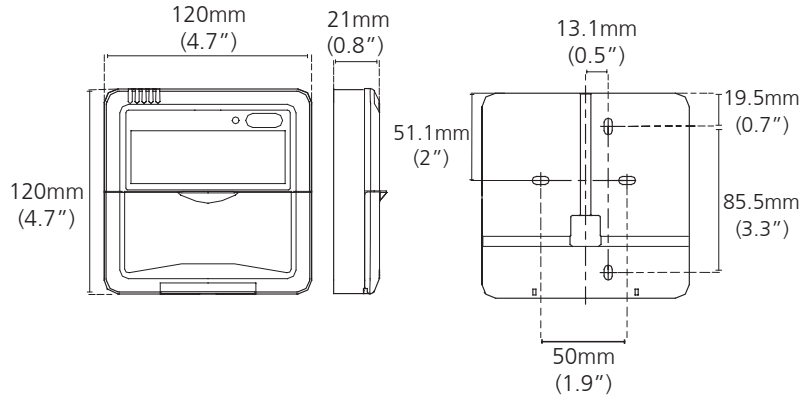

- Wiring diagram

Refer to the following diagram to wire the wall-mounted remote control to the indoor unit.

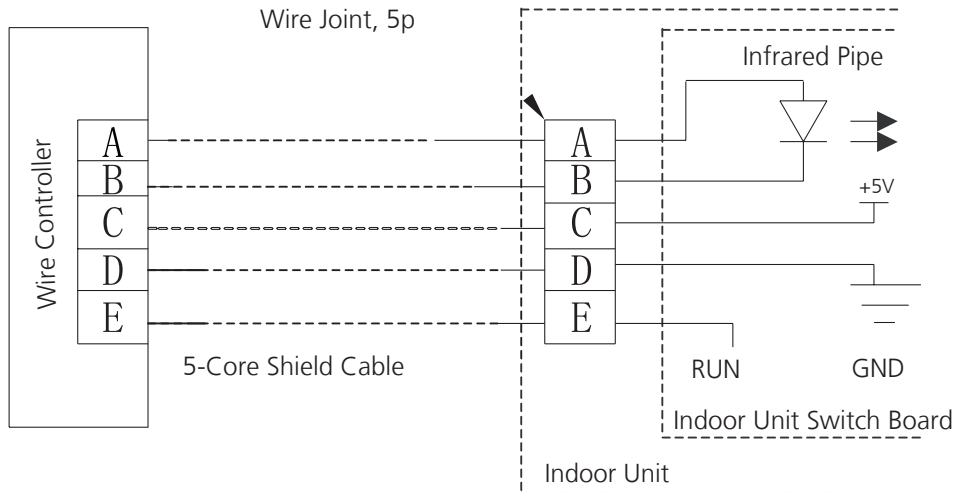

- Installation Diagram

Connect the wire from the display panel of the indoor unit to a connecting cable. Then connect the other side of the connecting cable to the remote control.

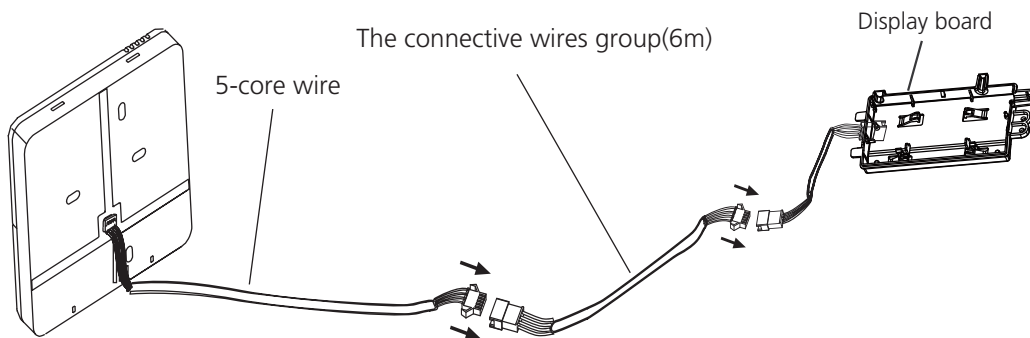

**Note:** Be sure to reserve a length of the connecting wire for periodic maintenance.

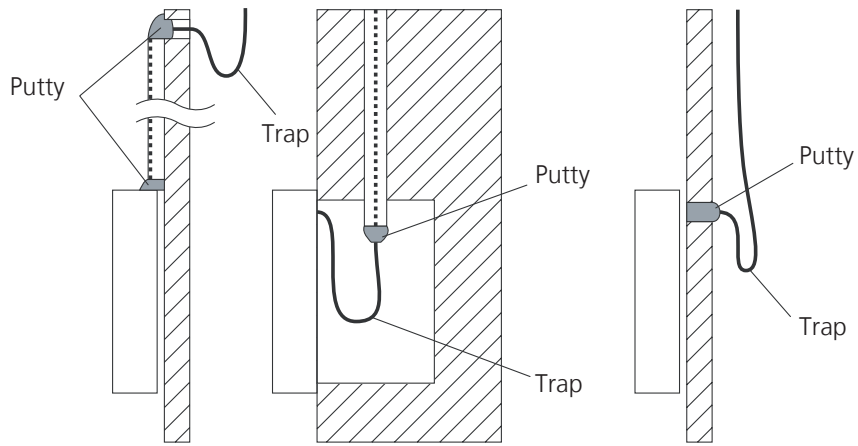

**Note: DO NOT** allow water to enter the remote control. Use the trap and putty to seal the wires.

- For exposed mounting, cut holes on four of the sides according to the picture below.

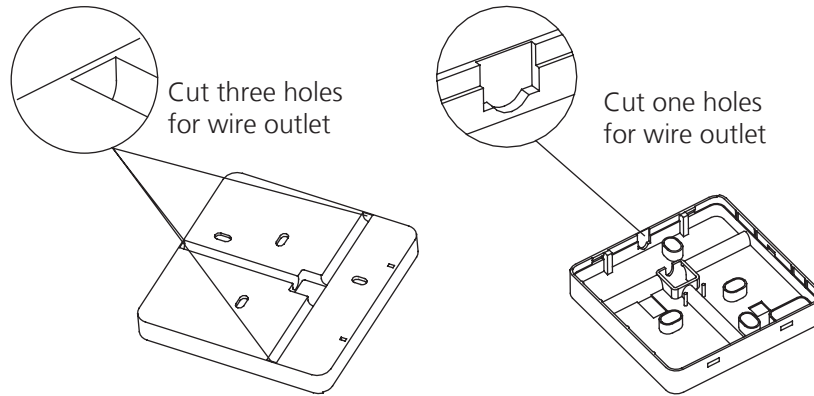

- For shielded wiring, please refer to the picture below.

Embedded switch box wiring

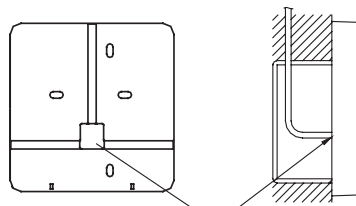

Wiring hole

Wiring through the wall

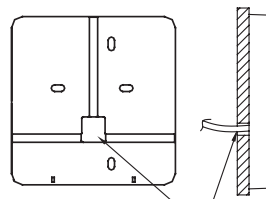

Wall hole and wiring hole  
Diameter of wall hole:  $\Phi$  2cm

## 2.2 Centralized Controller

### 1) Connection

For Light commercial air conditioner with XYE port, it can be directly connected to Centralized Controller (CCM03, CCM09).

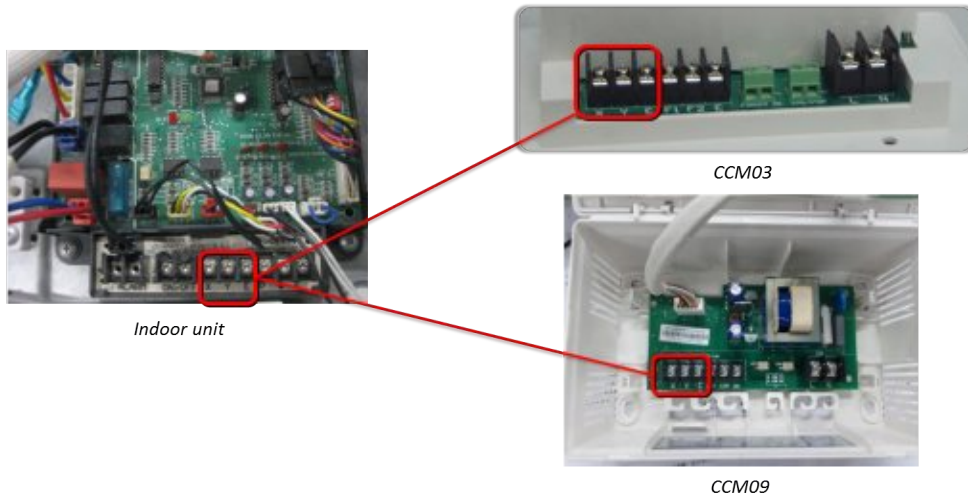

### 2) Address setting

When setting the address, please make sure the unit is powered off. The address can be set from 0 to 63 by the switch. Turn on the unit, then the address will be effective.

SWITCH		FOR CCM UNIT ADDRESS	
S2 + S1			
ADDRESS	0~15	16~31	
Factory Setting	✓		
S2 + S1			
ADDRESS	32~47	48~63	
Factory Setting			

Note: For light commercial air conditioner with XYE port, it can be also connected to BMS (Building Management System).

If there is any CAC (central air conditioner) connecting with the central controller at the same time, please set the address from largest (63,62,61...), since the CAC units could obtain address automatically from the smallest (00,01,02...)

### 2.3 Using the wire controller to set external static pressure

- You can use the unit’s automatic airflow adjustment function to set external static pressure.
- Automatic airflow adjustment is the volume of blow-off air that has been automatically adjusted to the quantity rated.

1. Make sure the test run is done with a dry coil. If the coil is not dry, run the unit for 2 hours in FAN ONLY mode to dry the coil.

2. Check that both power supply wiring and duct installation have been completed. Check that any closing dampers are open. Check that the air filter is properly attached to the air suction side passage of the unit.

3. If there is more than one air inlet and outlet, adjust the dampers so that the airflow rate of each air inlet and outlet conforms with the designed airflow rate. Make sure the unit is in FAN ONLY mode. Press and set the airflow adjustment button on the remote control to change the airflow rate from H or L.

4. Set the parameters for automatic airflow adjustment. When the air conditioning unit is off, perform the following steps:

- When the unit is turned off, hold the MODE button and FAN button down together for three seconds. (“AF” indicator flashes for 3 times.)

- Press “△” or “▽” to select the AF.

- Press “△” or “▽” to select the AF.

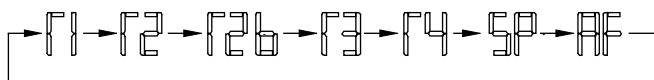

- Press “MODE”. The air conditioning unit will then start the fan for airflow automatic adjustment.

After 3 to 6 minutes, the air conditioning unit stops operating once automatic airflow adjustment has finished.

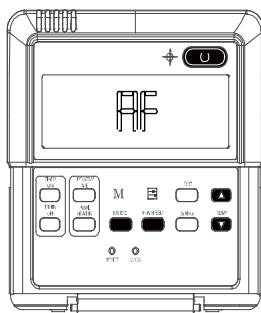

Caution: DO NOT adjust the dampers when automatic airflow adjustment is active.

Caution:

• If there is no change after airflow adjustment in the ventilation paths, be sure to reset automatic airflow adjustment.

• If there is no change to ventilation paths after airflow adjustment, contact your dealer, especially if this occurs after testing the outdoor unit or if the unit has been moved to a different location.

• Do not use automatic airflow adjustment with remote control, if you are using booster fans, outdoor air processing unit, or a HRV via duct.

• If the ventilation paths have been changed, reset airflow automatic adjustment as described from step 3 onwards.

### 2.4 Using the wire controller to set airflow rate

When the air conditioning unit is off, perform the following steps:

1. Press “MODE” and “FAN” for three seconds.

2. Press “△” or “▽” to select the SP.

3. Press “MODE” to set the airflow rate in the range of 0~4.

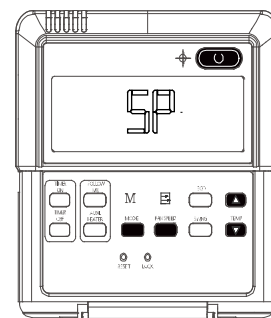

“0” : No airflow change

“1” ~ “4” : Airflow increase progressively

4. Press “ON/OFF” to finish the airflow setting.

---

# Static Pressure Design

## Contents

1.	Introduction .....	70
2.	Charts for Friction Losses in Round Ducts.....	71
3.	Dynamic Losses.....	72
4.	Corresponding Relation Between Rectangular Duct and Round Duct .....	73
5.	Method for Duct Calculation .....	74
6.	Unit Conversion .....	74
7.	Recommended Outlet Velocity for Different Occasions .....	74

## 1. Introduction

Duct system losses are the irreversible transformation of mechanical energy into heat. The two types of losses are (1) friction losses and (2) dynamic losses.

Friction losses are due to fluid viscosity and result from momentum exchange between molecules (in laminar flow) or between individual particles of adjacent fluid layers moving at different velocities (in turbulent flow). Friction losses occur along the entire duct length.

Dynamic losses result from flow disturbances caused by duct mounted equipment and fittings (e.g., entries, exits, elbows, transitions, and junctions) that change the airflow path's direction or area.

## 2. Charts For Friction Losses In Round Ducts

Fluid resistance caused by friction in round ducts can be determined by the friction chart. (based on galvanized sheet)

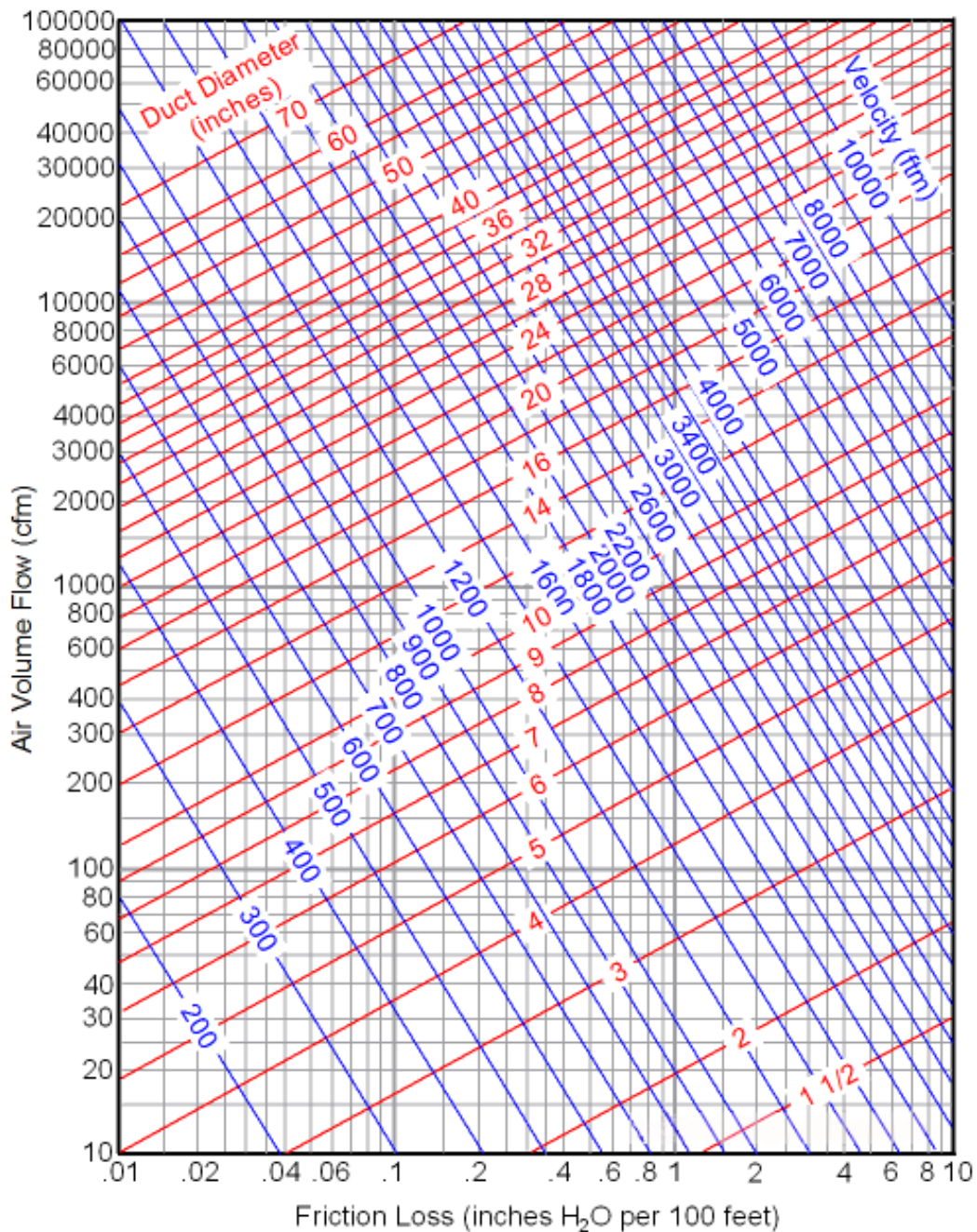

### 3. Dynamic Losses

For dynamic losses, please refer to below image.

Elbow ( $r/w = 1$ )		Sharp elbow ( $r/w = 0.5$ )		Branch Straight-Thru		Branch Thru-Branch ( $r/w = 1$ )		Reducer $\theta \leq 14^\circ$	
V m/s	loss mm H <sub>2</sub> O	V m/s	loss mm H <sub>2</sub> O	No friction loss		V m/s	loss mm H <sub>2</sub> O	V m/s	loss mm H <sub>2</sub> O
3.5~5	0.2	3.5~5	1			3.5~5	0.4	3.5~5	0.2
5~7	0.4	5~7	2			5~7	0.8	5~7	0.4
7~9	0.8 <sup>x</sup>	7~9	3.5 <sup>x</sup>			7~9	1.5 <sup>x</sup>	7~9	0.8 <sup>x</sup>
9~15	2	9~15	7			9~15	3	9~15	2
Anemostat		Gallery or louver		Register		Hopper			
V m/s	loss mm H <sub>2</sub> O	V m/s	loss mm H <sub>2</sub> O	V m/s	loss mm H <sub>2</sub> O	V m/s	loss mm H <sub>2</sub> O		
3.5~5	1	3.5~5	0.5	3.5~5	1.5	3.5~5	0.3		
5~7	2	5~7	1	5~7	3	5~7	0.6		
7~9	3.5	7~9	2	7~8	6	7~9	1		
9~15	6								

Note: W Shows a diameter of round duct or long side length of the rectangular duct.

#### 4. Corresponding Relation Between Rectangular Duct and Round Duct

Circular Duct Diameter, in.	Length of One Side of Rectangular Duct <sup>a</sup> , in.																					
	4	5	6	7	8	9	10	12	14	16	18	20	22	24	26	28	30	32	34	36		
	Length Adjacent Side of Rectangular Duct <sup>b</sup> , in.																					
5	5																					
5.5	6	5																				
6	8	6																				
6.5	9	7	6																			
7	11	8	7																			
7.5	13	10	8	7																		
8	15	11	9	8																		
8.5	17	13	10	9																		
9	20	15	12	10	8																	
9.5	22	17	13	11	9																	
10	25	19	15	12	10	9																
10.5	29	21	16	14	12	10																
11	32	23	18	15	13	11	10															
11.5		26	20	17	14	12	11															
12		29	22	18	15	13	12															
12.5		32	24	20	17	15	13															
13		35	27	22	18	16	14	12														
13.5		38	29	24	20	17	15	13														
14			32	26	22	19	17	14														
14.5			35	28	24	20	18	15														
15			38	30	25	22	19	16	14													
16			45	36	30	25	22	18	15													
17				41	34	29	25	20	17	16												
18				47	39	33	29	23	19	17												
19				54	44	38	33	26	22	19	18											
20					50	43	37	29	24	21	19											
21					57	48	41	33	27	23	20											
22					64	54	46	36	30	26	23	20										
23						60	51	40	33	28	25	22										
24						66	57	44	36	31	27	24	22									
25							63	49	40	34	29	26	24									
26							69	54	44	37	32	28	26	24								
27							76	59	48	40	35	31	28	25								
28								64	52	43	38	33	30	27	26							
29								70	56	47	41	36	32	29	27							
30								76	61	51	44	39	35	31	29	28						
31									82	66	55	47	41	37	34	31	29					
32									89	71	59	51	44	40	36	33	31					
33									96	76	64	54	48	42	38	35	33	30				
34										82	68	58	51	45	41	37	35	32				
35										88	73	62	54	48	44	40	37	34	32			
36										95	78	67	58	51	46	42	39	36	34			
37										101	83	71	62	55	49	45	41	38	36	34		
38										108	89	76	66	58	52	47	44	40	38	36		
39											95	80	70	62	55	50	46	43	40	37	36	
40											101	85	74	65	58	53	49	45	42	39	37	
41											107	91	78	69	62	56	51	47	44	41	39	
42											114	96	83	73	65	59	54	50	46	44	41	
43											120	102	88	77	69	62	57	53	49	46	43	
44												107	93	81	73	66	60	55	51	48	45	
45												113	98	86	76	69	63	58	54	50	47	
46												120	103	90	80	72	66	61	56	53	49	
47												126	108	95	84	76	69	64	59	55	52	
48												133	114	100	89	80	73	67	62	58	54	
49												140	120	105	93	84	76	70	65	60	56	
50												147	126	110	98	88	80	73	68	63	59	
51													132	115	102	92	83	76	71	66	61	
52													139	121	107	96	87	80	74	69	64	
53													145	127	112	100	91	83	77	71	67	
54													152	133	117	105	95	87	80	74	70	
55														139	123	110	99	91	84	78	72	
56														145	128	114	104	95	87	81	75	
57														151	134	119	108	98	91	84	78	
58															158	139	124	112	102	94	87	81
59															165	145	130	117	107	98	91	85
60															172	151	135	122	111	102	94	88

## 5. Method For Duct Calculation (equal friction method)

- 1) Draw schematic view of the duct system.
- 1) Make notes for air volume and mark clearly the elbow, the branch parts, the air discharge outlet.
- 1) Select one main ducting route (where the maximum static pressure loss occurs).
- 1) Select the air velocity for the main duct in accordance with the desirable air velocity.

Main duct	Typical design velocity (m/s)		
	Residence	Public building	Factory
	3.5~6.0	5.0~8.0	6.0~11.0

- 1) Since the velocity and air volume are fixed for main duct, then use the Friction loss chart to find standard friction loss.
- 1) Use air volume and friction loss to find corresponding duct size and velocity for each part of main duct through Frictions loss chart.
- 1) Find the dynamic loss of main ducting route according to the velocity. and type of special fittings (elbows, junctions, regulating flaps, etc.)
- 1) Obtain the duct size and velocity of each branch duct based on the air volume and the same standard friction loss as for the main duct.
- 1) Find the dynamic loss of branch duct.
- 1) Calculate the total pressure loss.

## 6. Unit Conversion

- 1 inch water=248.8 N/m<sup>2</sup> (Pa)=0.0361 lb/in<sup>2</sup> (psi)=25.4 kg/cm<sup>2</sup>=0.0739 in mercury
- 1 ft<sup>3</sup>/min (cfm)=1.7 m<sup>3</sup>/h
- 1 ft/min=5.08\*10<sup>-3</sup> m/s
- 1 inch=2.54 cm=0.0254m=0.08333ft

## 7. Recommended Outlet Velocity For Different Occasion

The permissible sound level and correspondingly maximum air velocity, is determined by the occasion.

Noise / dB(A)	Occasion	Maximum velocity / m/s
25	Studio, recording room	2
35	Cinema, hospital, library	3
40	Office, school, hotel	4
46	Bank, public hall	5
50	Store, post office	6
70	Factory	10