



Quality Assurance
Certificate Reg. No:
04 100 950420



Subject to change without notice
Manufacturing point: Jeddah, Saudi Arabia
Nearest port of embarkation: Jeddah Islamic port
Product classification: Commercial

Installation, Operation and Maintenance Instructions

50TJM – 50Hz Nominal Cooling Capacity 15 - 26 Tons HFC R-410A Refrigerant

Note: This manual discusses the Mechanical Installation of this unit, Start-up Procedures, Operating Sequences and Service Instructions.

Read thoroughly the entire installation instruction manual before starting the unit installation, to get familiarized with all steps and to identify if any additional reference materials as required.

The 50TJM units are single side discharge rooftop cooling unit utilizing electric heat as an option. Units are pre-wired, pre-charged with R-410A refrigerant, and tested at the factory. These units can be placed on the side of a building or can be placed on a roof without roof curbs. Each unit is designed to occupy a minimal space. Piping and drain connections are readily accessible.

For a complete list of options and accessories, refer to the Product Data Catalog.

Contact your local Carrier representative for additional reference materials.

Table of Contents

1.0 – SAFETY CONSIDERATIONS	3
1.1 – General	3
1.2 – Installation Safety Considerations	3
1.3 – Warranty	3
Physical Data.....	5
Unit Dimensional Drawing	6 – 8
2.0 – INSTALLATION.....	9
2.1 – Jobsite Survey	9
2.2 – Plan for Unit Location	9
2.3 – Rig and Place Unit.....	9
2.4 – Positioning and Clearance.....	10
2.5 – Field Fabricate Ductwork	10
2.6 – Make Unit Duct Connections	10
2.7 – Trap Condensate Drain	11
2.8 – Outdoor Air-Vent.....	11
2.9 – Make Electrical Connections	11
Electrical Data	12
Electrical Resistance Heater Data.....	13
Typical Wiring Schematic	14 – 15
3.0 – START-UP INSTRUCTIONS	16
3.1 – Unit Preparation	16
3.2 – Internal Wiring.....	16
3.3 – Compressor Mounting	16
3.4 – Refrigerant Service Ports.....	16
3.5 – Compressor Rotation.....	16
3.6 – Evaporator Fan	16
3.7 – Condenser Fans and Motors	17
3.8 – Return – Air Filters.....	17
3.9 – Base Unit Operation	17
4.0 – SERVICE	17
4.1 – Cleaning.....	17
4.2 – Lubrication	17
4.3 – Evaporator Fan Performance Adjustment	18
4.4 – Evaporator Fan Service and Replacement.....	18
4.5 – Belt Tension Adjustment.....	19
4.6 – Condenser – Fan Adjustment.....	19
4.7 – Refrigerant Charge	19
4.8 – Protective Devices	19
4.9 – Control Circuit, 24 – V.....	20
5.0 – REPLACEMENT PARTS	20
Fan Performance Table	21 – 22
Cooling Chart	23
Troubleshooting.....	24
Start-up Check List	25

1 – SAFETY CONSIDERATIONS

1.1 – General

Improper installation, adjustment, alteration, service, maintenance or use can cause explosion, fire, electrical shock or other conditions which may cause personal injury or property damage. Consult a qualified installer; service agency must use factory-authorized kits or accessories when modifying this product. Refer to the individual instructions packaged with the kits or accessories when installing.

The appliance is not to be used by persons (including children) with reduced physical, sensory or mental capabilities, or lack of experience and knowledge, unless they have been given supervision or instruction. Children should be supervised not to play with the appliance.

Follow all the safety codes. Wear safety glasses and work gloves. Use quenching cloths for brazing operations and have a fire extinguisher available. Read these instructions thoroughly and follow all warnings or cautions attached to the unit. Consult local building codes for special requirements. In absence of local codes, it is recommended that the USA standard ANSI/NFPA 70, National Electrical Code (NEC), be followed.

It is important to recognize safety information. This is the safety-alert symbol . When you see this symbol on the unit and in instructions or manuals, be alert to the potential for personal injury.

Understand the signal words DANGER, WARNING, CAUTION, and NOTE. These words are used with the safety-alert symbol. DANGER identifies the most serious hazards which **will** result in severe personal injury or death. WARNING signifies hazards which **could** result in personal injury or death. CAUTION is used to identify unsafe practices, which **may** result in minor personal injury or product and property damage. NOTE is used to highlight suggestions which **will** result in enhanced installation, reliability, or operation.

1.2 – Installation Safety Considerations

After the unit has been received and when it is ready to be installed or reinstalled, it must be inspected for damage. If damage is detected upon receipt, immediately file a claim with the shipping company or repair.

This machine must be installed in a location that is not accessible to the public and protected against access by non-authorized people.

This machine must not be installed in an explosive atmosphere.

Do not remove the skid or the packaging until the unit is in its final position. These units can be moved with a fork lift truck, as long as the forks are positioned in the right place and direction on the unit.

The units can also be lifted with slings, using only the designated lifting points marked on the unit (labels on the chassis and a label with all unit handling instructions are attached to the unit). Use slings with the correct capacity, and always follow the lifting instructions on the certified drawings supplied for the unit.

Safety is only guaranteed, if these instructions are carefully followed. If this is not the case, there is a risk of material deterioration and injuries to personnel. These units are not designed to be lifted from above.

1.3 – Warranty

Warranty is based on the general terms and conditions of the manufacturer. Any modifications to the design and/or installation made without discussion with Carrier and without advance written agreement will result in the loss of the right to any warranty claims and any claim for injury to personnel as a result of these modifications.



WARNING

ELECTRICALSHOCK HAZARD

Failure to follow this warning could cause personal injury, death and/or equipment damage.

Before performing service or maintenance operations on unit, always turn off main power switch to unit and install lockout tag.

Unit may have more than one power switch.



WARNING

UNIT OPERATION AND SAFETY HAZARD

Failure to follow this warning could cause personal injury, death and/or equipment damage.

Puron® (R-410A) refrigerant systems operate at higher pressures than standard R-22 systems. Do not use R-22 service equipment or components on Puron refrigerant equipment.



WARNING

PERSONAL INJURY AND ENVIRONMENTAL HAZARD

Failure to follow this warning could cause personal injury, death and/or equipment damage.

Relieve pressure and recover all refrigerant before system repair or final unit disposal.

Wear safety glasses and gloves when handling refrigerants. Keep torches and other ignition sources away from refrigerants and oils.



CAUTION

CUT HAZARD

Failure to follow this warning could cause personal injury.

Sheet metal parts may have sharp edges or burrs. Use care and wear appropriate protective clothing, safety glasses and gloves when handling parts and servicing furnaces.

Physical Data - English (Table 1)

50TJM Unit Physical Data (50Hz) (English)				
Unit 50TJM Size	18	22	26	32
Refrigeration System				
Compressor No. / Type	2 / Scroll			
Stage Of Capacity Control (%)	50 / 50			
Refrigerant Type	Puron ® R410A			
Circuits No.	2			
Charge Per Circuit (Down / Up) - LBS	18.14 / 16.53	23.59 / 23.59	31.20 / 29.32	28.66 / 26.90
Metering Device	TXV - Adjustable			
Filter Drier Qty / Size	2 / DML085S		2 / DMS165S	
High Pressure Switch (Trip / Reset) - PSIG	630 / 480			
Low Pressure Switch (Trip / Reset) - PSIG	54 / 70			
Freeze Protection Thermostat (Open / Close) ±1.8 °F	-18 / -14			
Condenser Coil				
Coil Type	Copper Tube, Aluminum Double Wavy Fins			Copper Tube, Aluminum LSW Fins
Standard Coil Material	Copper / Aluminium			
Qty x Rows x FPI	1 x 3 x 16	1 x 4 x 16	2 x 3 x 17	
Qty x Face Area (ft ²)	1 x 26.7		2 x 28.8	
Coil Test Pressure (PSIG)	450			
Condenser Fan & Motor				
Approx. Air Flow Rate (CFM)	12000	13000	16700	18200
Quantity	2			
Diameter (in) / No. of Blades	30 / 4		30 / 6	
Motor Type	Induction Motor - Totally Enclosed			
Motor HP / RPM	1 / 950			
Evaporator Coil				
Coil Type	Copper Tube, Aluminum LSW Fins.			
Standard Coil Material	Copper / Aluminium			
Qty x Rows x FPI	2 x 3 x 17		2 x 4 x 17	
Qty x Face Area (ft ²)	2 x 9.75		2 x 10.3	
Coil Test Pressure	350			
Drain Pan connection Size (in)	3/4			
Return Air Filter Qty x Size (in)	4 x 33.8 x 21.7		4 x 35.4 x 21.7	
Evaporator Fan and Motor Section				
Fan Quantity / Fan Size (in)	1 / 15.75 x 15.75		1 / 17.7 x 17.7	
Fan Type	Centrifugal - Forward Blade			
Drive Type	Belt			
Motor Type	Induction Motor - TEFC			
Motor BHP	4.0	5.4	7.4	
Motor Frame Size / Motor Shaft Diameter (mm)	100 / 28	112 / 28		132 / 38
Motor Pulley Pitch Diameter (Min / Max) (in)	3.7 / 4.7			4.3 / 5.6
Fan RPM Range (RPM)	755-953			733-970
Fan Pulley Pitch Diameter (in)	6.6			8.4
Belt, Quantity...Type	1 ... BX66			1 ... BX71
Pulley Center To Center Distance(in)	24.4 - 27.5			
Movable Pulley Maximum Full Turns From Closed Position	6			
Approx.Speed Change Per Full Turn Of Movable Pulley Flange (rpm)	48			
Factory Speed Turns Setting	4			1.5

Unit Dimensional Drawing: 50TJM - Size 18 and 22 (Design Series A and B)

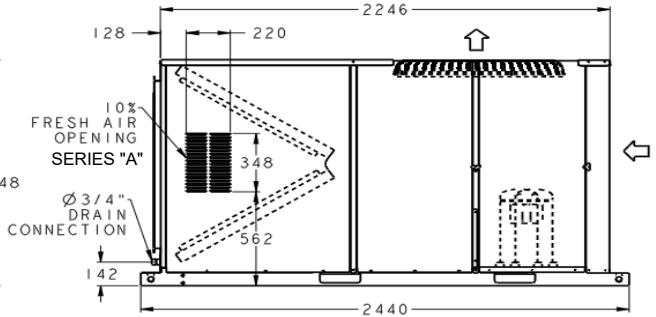
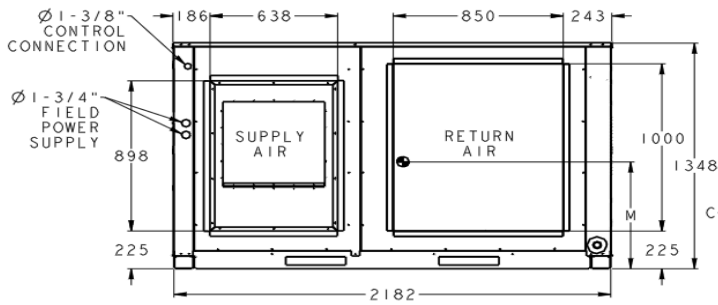
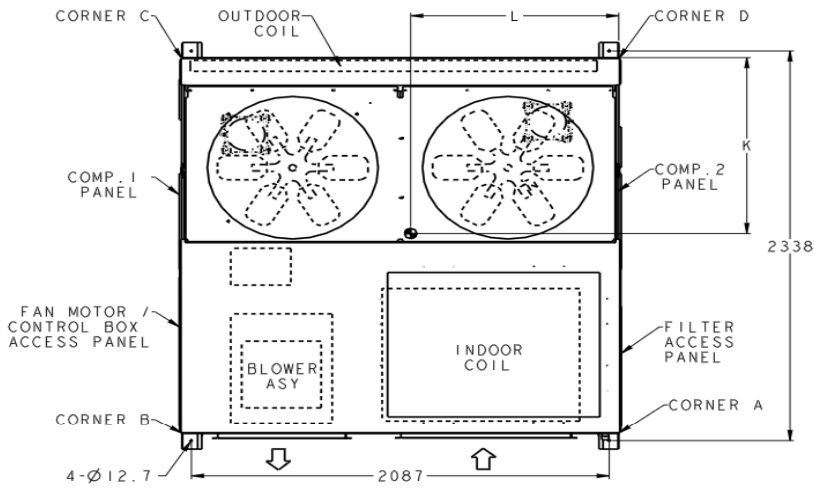

UNIT	SHIPPING DIMENSIONS (mm)			CORNER WEIGHT (Kg)					CENTER OF GRAVITY (mm)		
	LENGTH	WIDTH	DEPTH	A	B	C	D	TOTAL	K	L	M
50TJM - 18	2440	2235	1375	192	178	236	254	860	1050	1050	450
50TJM - 22				197	182	241	260	880			

NOTES:

- Dimensions are in millimeters.
- Center of Gravity.
- Direction of Airflow
- Minimum clearance:
 - REAR: 2134mm for coil removal. This dimension can be reduced to 1219mm if conditions permit coil removal from the top.
 - TOP: 1829mm to assure proper condenser fan operation.
 - SIDE: 1219mm for Compressor, Filter and Control boxes access.
 - Local codes or jurisdiction may prevail.
- With the exception of clearance for the condenser coil and the damper / power exhaust as stated in Note no. 6, a removal fence or barricade requires no
- Dimensions are from outside of corner post. Allow 8mm on each side for top cover drip edge.
- Weights are Given for aluminum evaporator and condenser coil plate fins.
- 10% Fresh air opening provision only on Design Series "A".
- Flange is only available in Design Series "A"

Unit Dimensional Drawing: 50TJM - Size 26 and 32 (Design Series A)

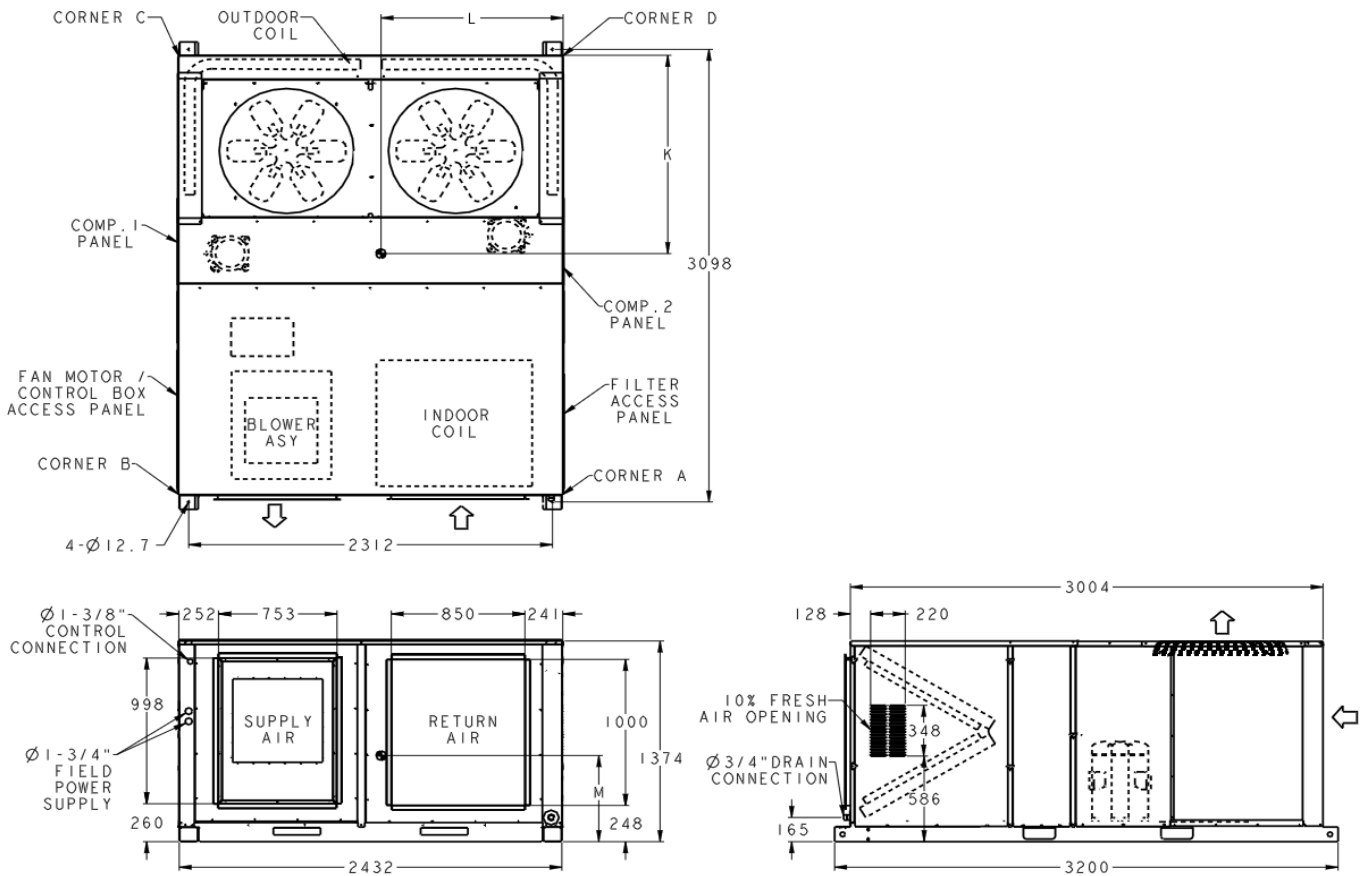

UNIT	SHIPPING DIMENSIONS (mm)			CORNER WEIGHT (Kg)					CENTER OF GRAVITY (mm)		
	LENGTH	WIDTH	DEPTH	A	B	C	D	TOTAL	K	L	M
50TJM - 26	3200	2485	1400	248	226	310	340	1125	1350	1160	450
50TJM - 32				254	231	317	348	1150			

- NOTES:**
- Dimensions are in millimeters.
 - ☉ Center of Gravity.
 - ⇨ Direction of Airflow
 - Minimum clearance:
 - REAR: 2134mm for coil removal. This dimension can be reduced to 1219mm if conditions permit coil removal from the top.
 - TOP: 1829mm to assure proper condenser fan operation.
 - SIDE: 1219mm for Compressor, Filter and Control boxes access.
 - Local codes or jurisdiction may prevail.
 - With the exception of clearance for the condenser coil and the damper / power exhaust as stated in Note no. 6, a removal fence or barricade requires no clearance.
 - Dimensions are from outside of corner post. Allow 8mm on each side for top cover drip edge.
 - Weights are Given for aluminum evaporator and condenser coil plate fins.
 - 10% Fresh air opening provision only on Design Series "A".
 - Flange is only available in Design Series "A".

Unit Dimensional Drawing: 50TJM - Size 26 and 32 (Design Series B)

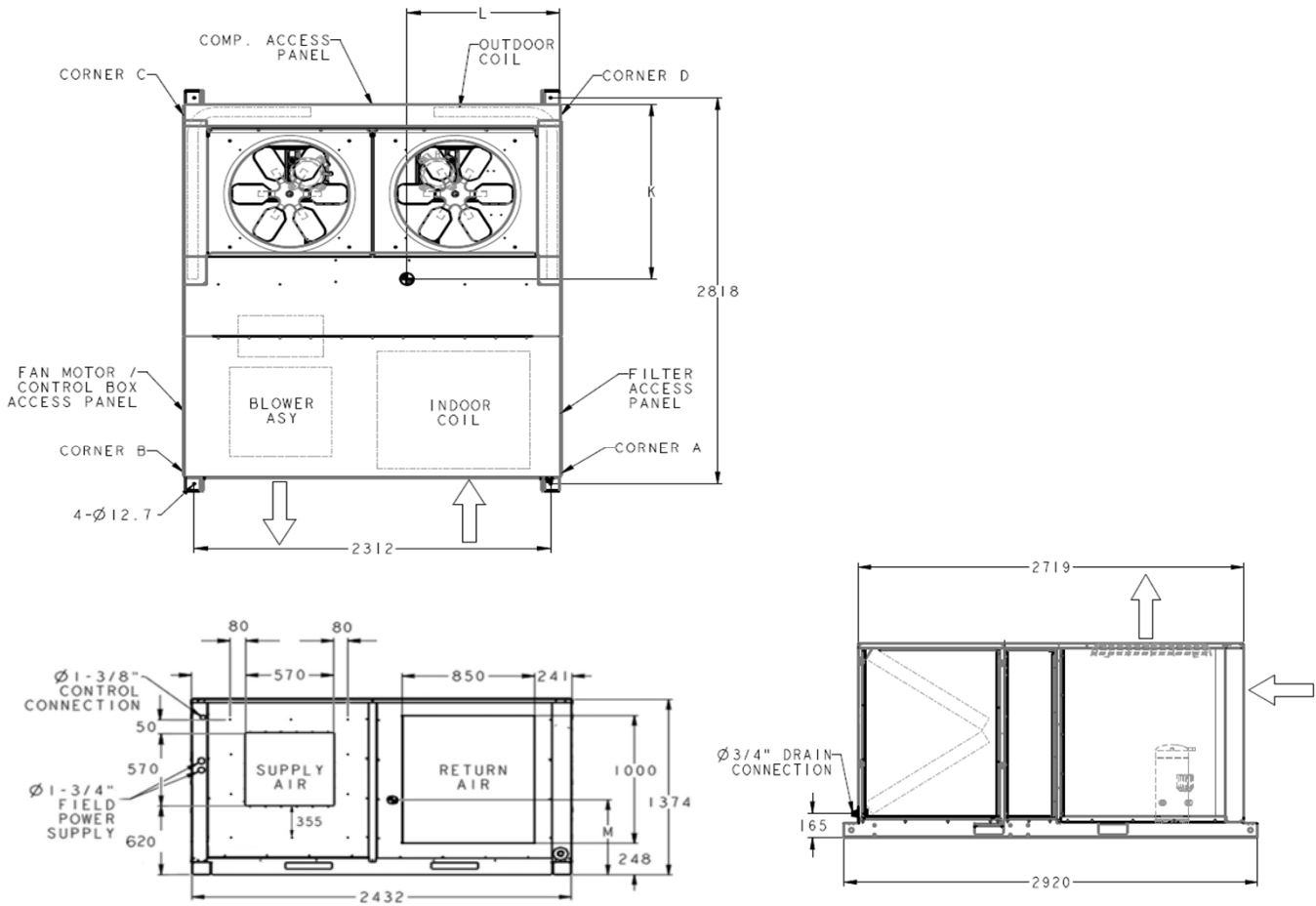

UNIT	SHIPPING DIMENSIONS (mm)			CORNER WEIGHT (Kg)					CENTER OF GRAVITY (mm)		
	LENGTH	WIDTH	DEPTH	A	B	C	D	TOTAL	K	L	M
50TJM - 26	2920	2485	1400	248	226	310	340	1125	1275	990	450
50TJM - 32				254	231	317	348	1150			

- NOTES:**
- Dimensions are in millimeters.
 - ☉ Center of Gravity.
 - ⇨ Direction of Airflow
 - Minimum clearance:
 - REAR: 2134mm for coil removal. This dimension can be reduced to 1219mm if conditions permit coil removal from the top.
 - TOP: 1829mm to assure proper condenser fan operation.
 - SIDE: 1219mm for access.
 - Local codes or jurisdiction may prevail.
 - With the exception of clearance for the condenser coil and the damper / power exhaust as stated in Note no. 6, a removal fence or barricade requires no clearance.
 - Dimensions are from outside of corner post. Allow 8mm on each side for top cover drip edge.
 - Weights are Given for aluminum evaporator and condenser coil plate fins.
 - 10% Fresh air opening provision only on Design Series "A".
 - Flange is only available in Design Series "A".

2 – INSTALLATION

2.1 – Jobsite Survey

Complete the following checks before installation.

1. Consult local building codes or the U.S.A. National Electrical Code (Ref: ANSI/NFPA 70, [American National Standards Institute/National Fire Protection Association], latest revision) for special installation requirements.
2. Determine unit location (from project plans) or select unit location.
3. Check for possible overhead obstructions which may interfere with unit lifting or rigging.

2.2 – Plan for Unit Location

Select a location for the unit and its support system (curb or other) that provides for the minimum clearances required for safety. This includes the clearance to combustible surfaces, unit performance and service access below, around and above unit as specified in Fig - 3. For the centre of gravity coordinates, the position of the unit mounting holes, and the weight distribution points, refer to the unit dimensional drawing Fig - 1 and Fig - 2.

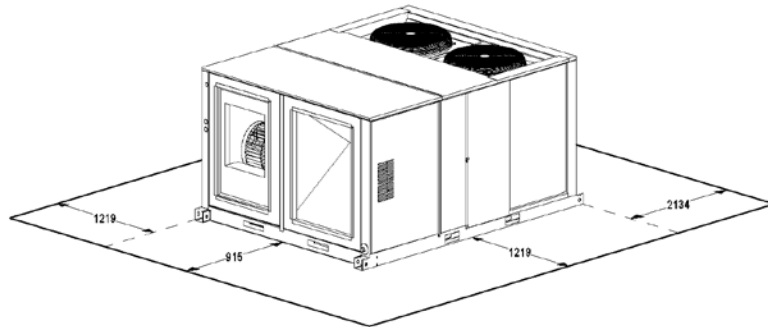

Fig. 3 Unit Clearance Diagram

NOTES:

1. Minimum clearance:

REAR: 2134mm for coil removal. This dimension can be reduced to 1219mm if conditions permit coil removal from the top.

TOP: 1829mm to assure proper condenser fan operation.

SIDE: 1219mm for Compressor, Filter and Control boxes access.

- Local codes or jurisdiction may prevail.

2. With the exception of clearance for the condenser coil and the damper / power exhaust as stated in Note no. 3, a removal fence or barricade requires no clearance.

3. Dimensions are from outside of corner post. Allow 8mm on each side for top cover drip edge.

2.3 – Rig and Place Unit

Keep unit upright and do not drop. Spreader bars are not required if top crating is left on unit.

Rollers may be used to move unit across a roof level by using unit frame as a reference; leveling tolerance is $\pm 1/16$ in. per linear ft in any direction.

Four lifting holes are provided in ends of unit base rails as shown in Fig – 4 Refer to rigging instructions on unit.

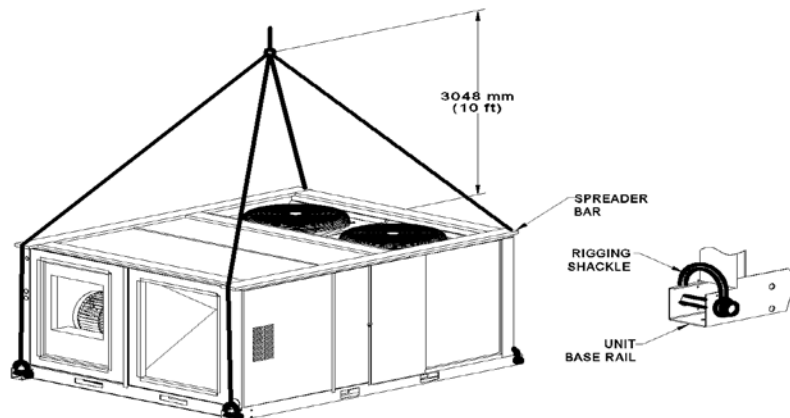

Fig. 4 Rigging Diagram

Roof mount - Check building codes for weight distribution requirements. Unit weight and dimensions is shown in unit dimensional drawing Fig 1 and Fig 2 on page 6 & 7 and table 2.

NOTE: Consider also the effect of adjacent units.

Unit Model Number	Unit Size Tons	Approximate Shipping Weight		Approximate Shipping Dimensions (L x D x H)	
		kg	lbs	mm	in
50TJM-18xxAxxxAxAS	15	925	2,017	2,440 x 2,235 x 1,375	96 x 88 x 54
50TJM-22xxAxxxAxAS	18	945	2,050		
50TJM-26AxAxAxAS	22	1,190	2,854	3,200 x 2,485 x 1,400	126 x 98 x 55
50TJM-32AxAxAxAS	26	1,215	2,877		
50TJM-26AxAxBxAS	22	1,190	2,854	2,920 x 2,485 x 1,440	115 x 98 x 55
50TJM-32AxAxBxAS	26	1,215	2,877		

Table – 2 Unit Weights and Dimensions

NOTES:

1. Remove boards at ends of unit and runners prior to rigging.
2. Rig by inserting hooks into unit base rails as shown. Use bumper boards for spreader bars.

NOTE

IMPORTANT

All units are internally isolated against vibration. If extra isolation required, please see “Unit Dimensional Drawing” Fig - 1 and Fig - 2 for corner weights.

CAUTION

UNIT DAMAGE HAZARD

Failure to follow this caution may result in equipment damage. All panels must be in place when rigging.

2.4 – Positioning and Clearance.

Before positioning the unit, check the following:

- The permitted loading at the site is adequate or that appropriate strengthening measures have been taken.
- The unit is installed level on an even surface (maximum tolerance is 5 mm in both axes).
- Ensure access to the components (see “Unit Dimensional Drawings” Fig 1 & 2 & “Clearance Diagram” Fig 3).
- The number of support points is adequate and that they are in the right places.
- Although the unit is weatherproof guard against water from higher level runoff and overhangs.

Unit may be installed directly on wood flooring or on approved roof - covering material when roof curb is used. Do not install unit in an indoor location. Do not locate air inlets near exhaust vents or sources of contaminated air.

2.5 – Field Fabricate Ductwork

Secure all ducts to building structure. Use flexible duct connectors between unit and ducts as required (*a space for 2.5 to 3ft is required in case of repairing or replacing the blower wheel*). Insulate and weatherproof all external ductwork, joints, and roof openings with counter flashing and mastic in accordance with applicable codes. Ducts passing through an unconditioned space must be insulated and covered with a vapor barrier.

The 50TJM units with electric heat require a 2-in. clearance for the first 24-in. of ductwork. Outlet grilles must not lie directly below unit discharge.

NOTE

IMPORTANT

A 90-degree elbow must be provided in drain hole and must be removed in ductwork to comply with UL (Underwriters’ Laboratories) codes for use with electric heat.

2.6 – Make Unit Duct Connections

Unit is shipped for side duct connections. Ductwork openings are shown in Fig. 1 and Fig. 2.

2.7 – Trap Condensate Drain

See Fig. 5, Fig.1 and Fig. 2 for drain pipe location. Trap should be deep enough to offset the maximum unit static difference. Fig. 5 shows the recommended trap sizing.

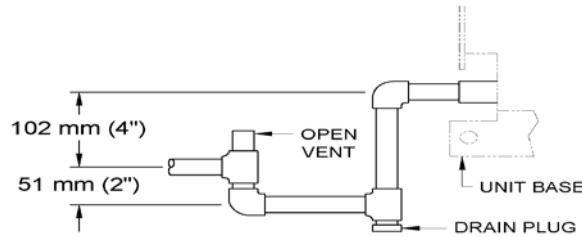

Fig. 5 Condensate Drain Details

2.8 – Outdoor Air-Vent

All units have a manual outdoor side vent to provide ventilation air. Side vents can admit up to 10% outdoor air into indoor air section return-air compartment.

2.9 – Make Electrical Connections

FIELD POWER SUPPLY – Unit is factory wired for voltage shown on nameplate.

When installing units, provide disconnect as per NEC (National Electrical Code) requirements, of adequate size. All field wiring must comply with NEC and local requirements. Route power lines through the corner post openings as shown in Fig. 1 and Fig. 2.

Operating voltage to compressor must be within voltage range indicated on unit nameplate. On 3-phase units, voltages between phases must be balanced within 2% and the current must be balanced within 10%.



CAUTION

UNIT DAMAGE HAZARD

Failure to follow this caution may result in equipment damage.

The correct power phasing is critical in the operation of the scroll compressors. An incorrect phasing will cause the compressor to rotate in the wrong direction. This may lead to premature compressors failure.



WARNING

ELECTRIC SHOCK HAZARD

Failure to follow this warning could result in personal injury or death.

Do not use gas piping as an electrical ground. Unit cabinet must have an uninterrupted, unbroken electrical ground to minimize the possibility of personal injury if an electrical fault should occur. This ground may consist of electrical wire connected to unit ground lug in control compartment, or conduit approved for electrical ground when installed in accordance with local electrical codes or in absence of local codes, it is recommended that U.S.A standard ANSI/NFPA 70, National Electrical Code be followed.

FIELD CONTROL WIRING – Install a Carrier approved accessory thermostat assembly according to the installation instructions included with the accessory. Locate thermostat assembly on a solid wall in the conditioned space to sense average temperature. Route thermostat cable or equivalent single leads of no. 18 AWG (American Wire Gage) colored wire from sub-base terminals through conduit in unit to low-voltage connection. Settings may be changed slightly to provide a greater degree of comfort for a particular installation.



NOTE

IMPORTANT

For wire runs up to 50 ft, use no. 18 AWG insulated wire. For 50 to 75 ft, use no. 16 AWG insulated wire. For over 75 ft, use no. 14 AWG insulated wire. All wire larger than no. 18 AWG cannot be directly connected to the thermostat and will require a junction box and splice at the thermostat.

Electrical Data (Table - 3)

50TJM Size				Compressor				OFM			IFM		Electric Heater		MCA	MOCP ◇
Unit Size 50TJM	Min Voltage	Max Voltage	Power Supply V / Ph / Hz	No.1		No.2		Qty	HP	FLA	HP	FLA	Appl. KW	FLA		
				RLA	LRA	RLA	LRA									
18	360	440	400 / 3 / 50	12.2	101	12.2	101	2	1	3.4	4.00	6.15	-	-	40.4	50
	360	440	400 / 3 / 50	12.2	101	12.2	101	2	1	3.4	4.00	6.15	21	30.3	44.0	50
22	360	440	400 / 3 / 50	16.7	111	16.7	111	2	1	3.4	5.50	8	-	-	52.4	60
	360	440	400 / 3 / 50	16.7	111	16.7	111	2	1	3.4	5.50	8	28	40.4	58.5	90
26	360	440	400 / 3 / 50	17.9	118	17.9	118	2	1	3	5.50	8	-	-	57.3	70
	360	440	400 / 3 / 50	17.9	118	17.9	118	2	1	3	5.50	8	28	40.4	61.5	100
32	360	440	400 / 3 / 50	21.8	140	21.8	140	2	1	3	7.50	11	-	-	66.1	80
	360	440	400 / 3 / 50	21.8	140	21.8	140	2	1	3	7.50	11	28	40.4	66.1	100

Legend and Notes for Electrical Data Table

- FLA** - Full Load Amps
- IFM** - Indoor (Evaporator) Fan Motor
- LRA** - Locked Rotor Amps
- MCA** - Minimum Circuit Amps
- MOCP** - Maximum Overcurrent Protection
- * Application heater kW @ 400 volt (Using multiplication factor table in Electric Resistance Heater Data)
- NEC** - National Electrical Code
- OFM** - Outdoor (Condenser) Fan Motor
- RLA** - Rated Load Amps
- HACR** - Heating, Air-Conditioning and Refrigeration
- ◇ Fuse or HACR Circuit Breaker

Unbalanced 3-Phase Supply Voltage

Never operate a motor where phase imbalance in supply voltage is greater than 2%.

Use the following formula to determine the percentage of voltage imbalance

$$= 100 \times \frac{\text{Maximum Deviation From Average Voltage}}{\text{Average Voltage}}$$

Example: Supply Voltage is 400V - 3ph - 50Hz

AB = 392v	Average Voltage = $\frac{392 + 404 + 395}{3}$
BC = 404v	
AC = 395v	$= \frac{1191}{3} = 397V$

Determine maximum deviation from average voltage.

(AB) 397 - 392 = 5v

(BC) 404 - 397 = 7v

(AC) 457 - 397 = 2v

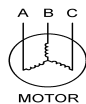

Maximum Deviation is 7v.

Determine Percentage Voltage Imbalance.

$$\% \text{ Voltage Imbalance} = 100 \times \frac{7}{397} = 1.76\%$$

This amount of phase imbalance is satisfactory as it is below the maximum allowable 2%

IMPORTANT: If the supply voltage phase imbalance is more than 2% contact your local electric utility company

Electric Heater Data (Table - 4)

UNIT 50TJM	Unit Voltage		Heater Stages	Heat Per Stage	Minimum Heating	
	400V				Cfm	L/s
	Application kW	Heater FLA (Per Stage)				
18	21kW	15.2	2	50/50	4800	2265
22	28kW	20.2			6000	2832
26					7000	3304
32						

Accessory Heater Part Number						
UNIT 50TJM	400V			Description	Stages	Rated (KW)
	Complete Kit P.N.	Casing P.N. (1 Per Kit)	Heater Element P. N. (2 Per Kit)			
	18	50TJ600287	50TJ600289			
22	50TJ601162	CPHEATER037A00		40		
26	50TJ600730		50TJ600727			
32						

NOTE: Heaters are rated at 480 V. Use the Multiplication Factors table below to determine heater capacity for your particular voltage.

Multiplication Factors			
Heater Rating Voltage	Actual Heater Voltage		
	380	400	480
480	0.62	0.7	1

NOTE: The following equation converts kW of heat energy to Btuh: kW x 3.413 = Btuh.

EXAMPLE: 30 kW (at 480V) heater on 400V

= 30.0 (0.7 multiplication factor)

= 21kW

Heater capacity (kW) is based on heater rated capacity at 480V. If power distribution voltage to unit varies from heater voltage, heater kW will vary accordingly. To Determine heater capacity at actual unit voltage, multiply 480v capacity by multipliers found in table " Multiplication Factors" above.

MCA calculation for 50TJM 18 - 32 size units with electric heaters over 50 kW = (1.25 x IFM amps) + (1.00 x heater FLA).

Typical Wiring Schematic (18/22/26/32) 400V - 50Hz

CONTROL BOX COMPONENT ARRANGEMENT

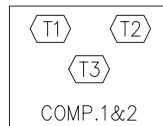
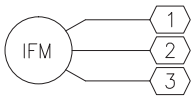
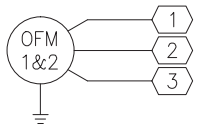
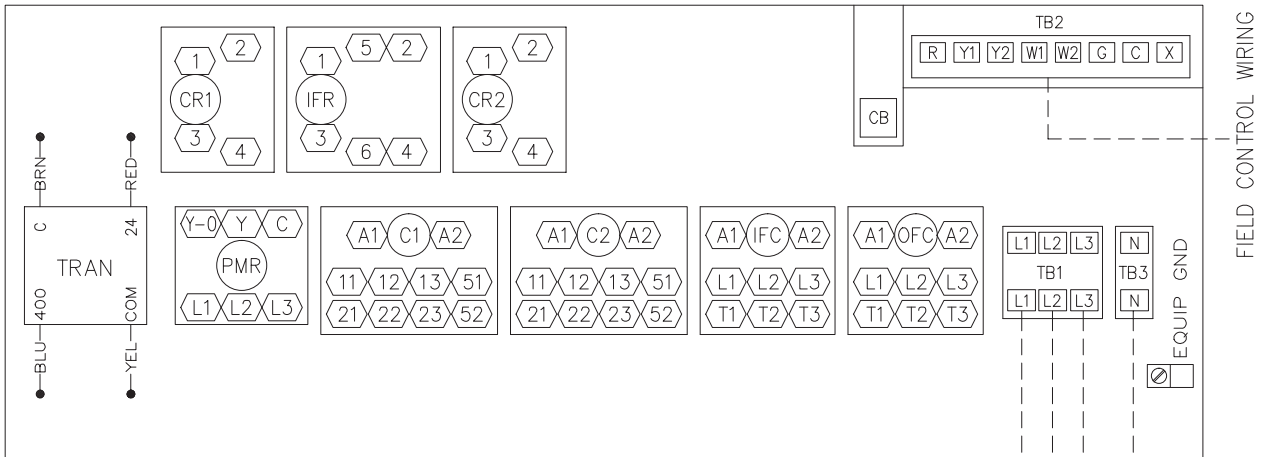

FIELD POWER WIRING
DISCONNECT PER NEC

L1-H-T1	11-H-21
L2-H-T2	12-H-22
L3-H-T3	13-H-23
21-H-22	51-H-52
TJM-18A2 COM1	TJM-18 A2 COM2
TJM-18A9 COM1 & COM2	TJM -24/28/34 A2 COM1 & COM2
TJM-24 A9 COM1 & COM2	TJM-28/34 A9 COM1 & COM2

LEGEND:

- TERMINAL (MARKED)
- TERMINAL (UNMARKED)
- TERMINAL BLOCK
- SPLICE

- FACTORY WIRING
- FIELD WIRING
- OPTION / ACCESSORY WIRING
- TO INDICATE COMMON POTENTIAL ONLY:
NOT TO REPRESENT WIRING

- | | | | |
|------|------------------------------|------|-----------------------|
| C | CONTACTOR | IFM | INDDOOR FAN MOTOR |
| CB | CIRCUIT BREAKER | IFR | INDOOR FAN RELAY |
| CH | CRANKCASE HEATER | L | INDICATOR LAMP |
| COMP | COMPRESSOR MOTOR | LPS | LOW PRESSURE SWITCH |
| CR | COMPRESSOR RELAY | OFC | OUTDOOR FAN CONTACTOR |
| FPT | FREEZE PROTECTION THERMOSTAT | OFM | OUTDOOR FAN MOTOR |
| FU | FUSE | PMR | PHASE MONITOR RELAY |
| GND | GROUND | PTO | MOTOR THERMOSTAT (NC) |
| HC | HEATER CONTACTOR | TB | TERMINAL BLOCK |
| HPS | HIGH PRESSURE SWITCH | TRAN | TRANSFORMER |
| IFC | INDOOR FAN CONTACTOR | TOL | THERMAL OVER LOAD |

NOTES:

- 1) IF ANY OF THE ORIGINAL WIRE FURNISHED MUST BE REPLACED, IT MUST BE REPLACED WITH TYPE 105°C WIRE OR ITS EQUIVALENT.
- 2) USE COPPER, COPPER CLAD, OR ALUMINUM CONNECTORS.
- 3) USE COPPER CONDUCTOR ONLY.
- 4) COMPRESSORS & FAN MOTORS ARE THERMALLY PROTECTED.
THREE PHASE MOTORS ARE PROTECTED AGAINST PRIMARY SINGLE PHASING CONDITIONS.
- 5) FOR CONTACTOR CONNECTION REFER TO ABOVE TABLE
- 6) APPLICABLE ONLY OUT DOOR MOTOR WITH EXTERNAL TOL CONNECTION

Typical Wiring Schematic (18/22/26/32) 400V - 50Hz

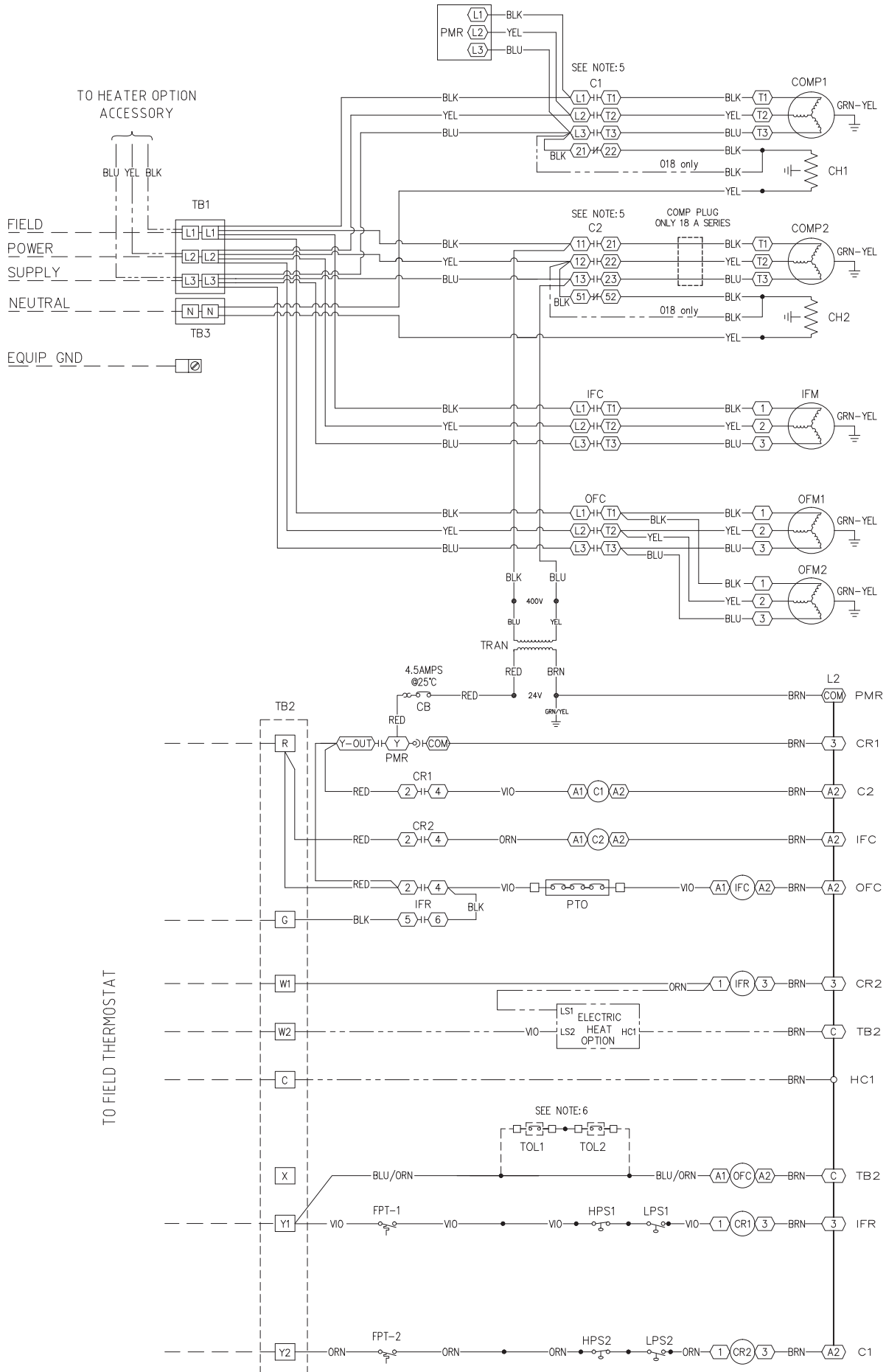

3 – START-UP INSTRUCTIONS

Use the following instructions and start-up checklist provided on the last page to check out the unit PRIOR to unit start-up.

3.1– Unit Preparation

Check that unit has been installed in accordance with these installation instructions and all applicable codes.

3.2 – Internal Wiring

Check all electrical connections in unit control boxes; tighten as required.

3.3 – Compressor Mounting

Compressors are internally spring mounted. Do not loosen or remove compressor hold down bolts.

3.4 – Refrigerant Service Ports

Each refrigerant system has a total of 3 Schrader type Service gage ports. One port is located on the suction line, one on the compressor discharge line, and one on the liquid line. In addition Schrader-type valves are located underneath the pressure switches. Be sure that caps on the ports are tight.

3.5 – Compressor Rotation

It is important to be certain the compressors are rotating in the proper direction. To determine whether or not compressors are rotating in the proper direction:

1. Connect service gages to suction and discharge pressure fittings.
2. Energize the compressor.
3. The suction pressure should drop and the discharge pressure should rise, as is normal on any start-up.

If the suction pressure does not drop and the discharge pressure does not rise to normal levels:

1. Note that the evaporator fan is probably also rotating in the wrong direction.
2. Turn off power to the unit.
3. Reverse any two of the compressor lead wires.
4. Turn on power to the compressor.
5. Check also phase monitor all ok green led before proceeding.

The suction and discharge pressure levels should now move to their normal start-up levels.



NOTE

IMPORTANT

When compressors are rotating in the wrong direction, the unit will have increased noise levels and will not provide heating and cooling. After a few minutes of reverse operation, the scroll compressor internal overload protection will open, which will activate the unit's lockout and requires a manual reset. Reset accomplished by turning the thermostat on and off.

3.6 - Evaporator Fan

Fan belt and variable pulleys are factory installed. Remove tape from the fan pulley. See Table 5 for Air Quantity Limits. See Table 7 for Fan Performance data. Be sure that fans rotate in the proper direction. See Table 6 for Fan RPM at various fan motor pulley settings. To alter fan performance, see Evaporator Fan Performance Adjustment section.

Unit	Cooling		Electric Heaters	
	Minimum	Maximum	Minimum	Maximum
50TJM-18	3,000	6,000	4,800	7,000
50TJM-24	4,000	6,500	6,000	6,000
50TJM-28	4,000	7,500	7,000	7,000
50TJM-34	6,000	9,000	7,000	7,000

Table 5 – Air Quantity Limits.

Freq.	Unit 50TJM	Motor Pulley Turns Open - (English)												
		0	1/2	1	1 1/2	2	2 1/2	3	3 1/2	4	4 1/2	5	5 1/2	6
50Hz	18	-	-	953	933	913	894	874	854	834	814	795	775	755
	22	-	-	953	933	913	894	874	854	834	814	795	775	755
	26	-	-	953	933	913	894	874	854	834	814	795	775	755
	32	970	950	931	911	891	871	852	832	812	792	773	753	733

Bold Fan RPM is Factory Setting

Table 6 – Fan RPM at Motor Pulley Settings.

3.7– Condenser Fans and Motors

Fans and motors are factory set. Refer to Condenser-Fan Adjustment Section as required.

3.8– Return – Air Filters

Check that correct filters are installed in filter tracks. See Table 1 “Physical data”. Do not operate unit without return-air filters.

3.9 – Base Unit Operation

COOLING, UNITS — when thermostat calls for cooling, terminals G and Y1 are energized. The indoor (evaporator) fan contactor (IFC), and compressor contactor no. 1 (C1) are energized and evaporator-fan motor, compressor no. 1 and condenser fans start. The condenser-fan motors run continuously while unit is cooling. If the thermostat calls for a second stage of cooling by energizing Y2, compressor contactor no. 2 (C2) is energized and compressor no. 2 starts.

HEATING, UNITS — (If Accessory or Optional Heater is installed) — upon a call for heating through terminal W1, IFC and heater contactor no. 1 (HC1) are energized.

4.0 – SERVICE

4.1 – Cleaning

Inspect unit interior at beginning of each heating and cooling season and as operating conditions require. Remove unit top panel and/or side panels for access to unit interior.

EVAPORATOR COIL — Clean as required with a commercial coil cleaner.

CONDENSER COIL — Clean condenser coil annually and as required by location and outdoor-air conditions. Inspect coil monthly — clean as required.

CONDENSATE DRAIN — Check and clean each year at start of cooling season.

FILTERS — Clean or replace at start of each heating and cooling season, or more often if operating conditions require. Refer to Table 1 “Physical Data” type and size.

4.2 – Lubrication

Compressors are charged with the correct amount of oil at the factory.

Replacing Compressor - In the case of a motor burnout, the majority of contaminated will be removed with the compressor. The rest of the oil is cleaned through the use of suction and liquid line filter driers. A 100% activated alumina suction line filter drier is recommended but must be removed after 72 hours.

The compressor contains POE oil. POE oil has a high affinity for moisture. Do not remove the compressor’s tube plugs until ready to insert the unit suction and discharge tube ends. The discharge connection plug should be removed first before pulling the suction connection plug to allow the dry air pressure inside the compressor to escape.

Note: This is only valid for the R410A systems.



CAUTION

UNIT DAMAGE HAZARD

Failure to follow this caution may result in damage to components.

1. The compressor is in a Puron® refrigerant system and uses a (POE) lubricant Emkarate RL 32 3MAF. In the field the oil level could be topped up with Mobil EAL Arctic 22 CC if 3MAF is not available. POE oil is extremely hygroscopic, meaning it absorbs water readily. POE oils can absorb 15 times as much as other oils designed for HCFC and CFC refrigerants. Avoid exposure of the oil to the atmosphere.
2. Ensure that system is not subjected to liquid abuse. Turn the crankcase heater on 12 hours before starting the compressor.

CONDENSER AND EVAPORATOR-FAN MOTOR BEARINGS – The condenser and evaporator-fan motors have permanently-sealed bearings, so no field lubrication is necessary.

4.3 – Evaporator Fan Performance Adjustment

NOTE: To remove belts only, follow Steps 1, 2 & 6. Fan motor pulleys are factory set speed shown in Table 6.

To change fan speeds:

1. Shut off unit power supply.
2. Loosen belt by loosening fan motor mounting plate nuts. Slide the Motor and remove belt.
3. Loosen movable-pulley flange setscrew (see Fig. 8).
4. Screw movable flange toward fixed flange to increase speed and away from fixed flange to decrease speed. Increasing fan speed increases load on motor. Do not exceed maximum speed specified in Table 6. See Table 7 for air flow.
5. Set movable flange at nearest keyway of pulley hub and tighten setscrew. (See Table 1 & 6 for speed change for each full turn of pulley flange.)
6. Replace and tighten belts. See Belt Tension Adjustment section on table 1.

To align fan and motor pulleys:

1. Loosen fan pulley setscrews.
2. Slide fan pulley along fan shaft.
3. Make angular alignment by loosening motor from mounting plate.

4.4 – Evaporator Fan Service and Replacement

1. Remove supply-air section panel (The bolts holding the flexible connection to the panel should be removed).
2. Remove the Control Side panel.
3. Remove the Belt (refer to the previous section for Belt removal).
4. Remove the locking device of the hub & shaft from the both sides; it can be accessed through the fan side panel.
5. Pull the shaft gently from the control side, the blower will fall inside the blower housing.
6. Loosen the (lower) first two bolts from each side of the scroll fan housing mid-plate. This can be done from the supply panel side, now the fan can be removed easily from the supply panel side.
7. To assemble the fan, reverse the above procedure.

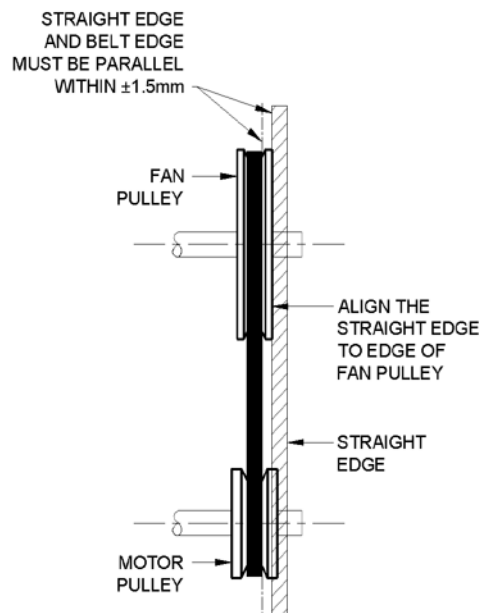

Fig. 8 Evaporator – Fan Pulley Alignment and Adjustment

4.5 – Belt Tension Adjustment

To adjust belt tension:

1. Loosen fan motor bolts.
2. Adjust belt tension by sliding the motor on the mounting base.
3. Tighten nuts.
4. Adjust bolts and nut on mounting plate to secure motor in fixed position.

4.6 – Condenser-Fan Adjustment

1. Shut off unit power supply.
2. Remove fan top-grille assembly and loosen fan hub screws.
3. Adjust fan height on unit, using a straightedge placed across the fan orifice.
4. Tighten setscrews

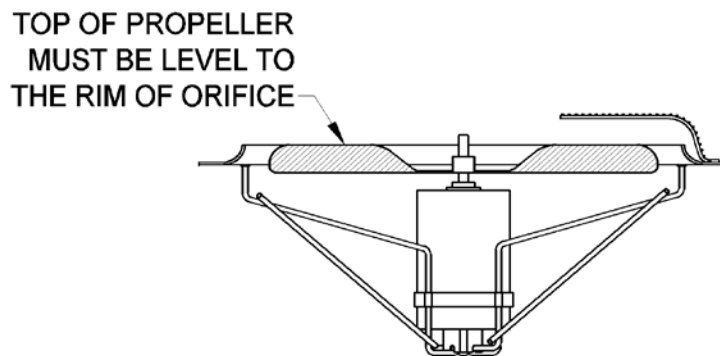

Fig. 9 Condenser - Fan Adjustment

4.7 – Refrigerant Charge

Amount of refrigerant charge is listed on unit nameplate and in Table 1. Refer to Carrier GTAC II; Module 5; Charging, Recovery, Recycling, and Reclamation section for charging methods and procedures. Unit panels must be in place when unit is operating during charging procedure.

NOTE: Do not use recycled refrigerant as it may contain contaminants.

NO CHARGE — Use standard evacuating techniques. After evacuating system, weight in the specified amount of refrigerant (refer to Table 1).

LOW CHARGE COOLING — Using cooling charging chart (see Fig. 10 to 13 according to the size of the unit) Add or remove refrigerant until conditions of the chart are met. Note that charging chart is different from those normally used. An accurate pressure gage and temperature-sensing device is required. Charging is accomplished by ensuring the proper amount of liquid sub-cooling. Measure liquid line pressure at the liquid line service valve using pressure gage.

Connect temperature sensing device to the liquid line near the liquid line service valve and insulate it so that outdoor ambient temperature does not affect reading.

TO USE THE COOLING CHARGING CHART — Use the above temperature and pressure readings, and find the intersection point on the cooling charging chart. If intersection point on chart is above line, add refrigerant. If intersection point on chart is below line, carefully recover some of the charge. Recheck suction pressure as charge is adjusted.

NOTE: Indoor-air CFM must be within normal operating range of unit. All outdoor fans must be operating.

4.8 – Protective Devices

COMPRESSOR PROTECTION – Each compressor is internally protected against over temperature.

To reset, manually move the thermostat setting.

EVAPORATER AND CONDENSER-FAN MOTOR PROTECTION — Each Evaporator and Condenser-fan motor is internally protected against over temperature.

HIGH- AND LOW-PRESSURE SWITCHES — If either switch trips. To reset, manually move the thermostat setting.

FREEZE PROTECTION THERMOSTAT (FPT) — An FPT is located on the top and bottom of the evaporator coil. It detects frost build-up and turns off the compressor, allowing the coil to clear. Once the frost has melted, the compressor can be reenergized.



NOTE

IMPORTANT

After prolonged shutdown or servicing in cold weather, energize the crankcase heaters for 12 hours before starting the compressors.

4.9 – Control Circuit, 24-V

This control circuit is protected against over-current by a 3.2-amp circuit breaker. Breaker can be reset. If it trips, determine cause of trouble before resetting.

5.0 – REPLACEMENT PARTS

A complete list of replacement parts may be obtained from any Carrier distributor.

Fan Performance Table - 7

Unit - 50TJM-018

Air Flow Rate (CFM)	Available External Static Pressure (in. wg)														
	0.2			0.4			0.6			0.8			1.0		
	RPM	KWI	BHP	RPM	KWI	BHP	RPM	KWI	BHP	RPM	KWI	BHP	RPM	KWI	BHP
3000	555	0.93	1.04	622	1.13	1.27	686	1.36	1.52	747	1.59	1.78	804	1.84	2.06
3500	589	1.20	1.34	652	1.42	1.59	711	1.65	1.86	767	1.90	2.14	823	2.17	2.43
4000	624	1.51	1.69	682	1.75	1.96	737	2.01	2.25	790	2.27	2.54	841	2.54	2.85
4500	658	1.87	2.10	711	2.13	2.39	762	2.40	2.69	813	2.68	3.00	861	2.96	3.32
5000	689	2.28	2.56	739	2.55	2.86	788	2.83	3.18	835	3.13	3.51	881	3.43	3.85
5500	721	2.74	3.07	765	3.01	3.38	811	3.31	3.71	855	3.62	4.06	899	3.93	4.41
6000	745	3.20	3.59	788	3.49	3.92	830	3.80	4.26	873	4.12	4.62	914	4.45	4.99

Unit - 50TJM-018 (cont)

Air Flow Rate (CFM)	Available External Static Pressure (in. wg)														
	1.2			1.4			1.6			1.8			2.0		
	RPM	KWI	BHP	RPM	KWI	BHP	RPM	KWI	BHP	RPM	KWI	BHP	RPM	KWI	BHP
3000	859	2.09	2.35	910	2.43	2.72	953	2.62	2.94	1007	2.90	3.25	1052	3.18	3.57
3500	875	2.44	2.73	924	2.72	3.05	971	3.00	3.37	1018	3.29	3.70	1062	3.60	4.04
4000	891	2.83	3.17	939	3.13	3.51	986	3.43	3.85	1030	3.74	4.20	1073	4.06	4.55
4500	909	3.27	3.66	955	3.58	4.01	998	3.89	4.36	1042	4.23	4.74	1083	4.56	5.11
5000	925	3.74	4.20	969	4.07	4.56	1012	4.40	4.94	1054	4.75	5.32	1094	5.10	5.72
5500	942	4.26	4.78	983	4.60	5.15	1024	4.94	5.54	1065	5.30	5.94	1104	5.66	6.35
6000	954	4.79	5.37	994	5.13	5.76	1034	5.49	6.16	1072	5.86	6.57	1110	6.24	7.00

Unit - 50TJM-22

Air Flow Rate (CFM)	Available External Static Pressure (in. wg)														
	0.2			0.4			0.6			0.8			1.0		
	RPM	KWI	BHP	RPM	KWI	BHP	RPM	KWI	BHP	RPM	KWI	BHP	RPM	KWI	BHP
4000	583	1.30	1.48	642	1.51	1.73	698	1.75	2.00	754	1.99	2.28	805	2.25	2.58
4500	617	1.62	1.86	672	1.86	2.13	724	2.10	2.41	788	2.36	2.70	825	2.63	3.01
5000	654	2.01	2.30	704	2.26	2.58	752	2.51	2.88	800	2.79	3.19	847	3.07	3.51
5500	689	2.44	2.80	735	2.71	3.10	781	2.98	3.41	826	3.27	3.74	871	3.57	4.08
6000	725	2.95	3.37	768	3.22	3.69	811	3.51	4.02	854	3.81	4.36	895	4.12	4.72
6500	761	3.51	4.02	802	3.80	4.35	842	4.11	4.70	882	4.42	5.06	921	4.74	5.43

Unit - 50TJM-22 (cont)

Air Flow Rate (CFM)	Available External Static Pressure (in. wg)														
	1.2			1.4			1.6			1.8			2.0		
	RPM	KWI	BHP	RPM	KWI	BHP	RPM	KWI	BHP	RPM	KWI	BHP	RPM	KWI	BHP
4000	856	2.52	2.88	906	2.80	3.20	953	3.08	3.53	998	3.37	3.86	1040	3.67	4.20
4500	874	2.91	3.34	920	3.20	3.67	966	3.50	4.01	1009	3.81	4.36	1052	4.13	4.72
5000	893	3.37	3.85	938	3.67	4.20	980	3.98	4.56	1023	4.30	4.93	1064	4.63	5.30
5500	913	3.87	4.43	953	4.19	4.79	998	4.51	5.17	1038	4.85	5.55	1077	5.20	5.95
6000	936	4.44	5.08	976	4.77	5.46	1016	5.11	5.85	1055	5.46	6.25	1094	5.82	6.66
6500	959	5.07	5.80	998	5.41	6.20	1035	5.77	6.60	1073	6.13	7.02	1110	6.50	7.44

Legend & Notes:

RPM - Revolutions Per Minute

KWI - Kilo Watts Input to Motor

Bold, Italics - Standard Motor and Drive Package

BHP - Brake Horsepower Input to Fan

CFM - Cubic Feet per Minute

in.wg - Inch Water Gauge

- Do not adjust motor rpm such that motor maximum bhp and/or watts is exceeded at the maximum operatin cfm.
- Static Pressure (i.e Filters) must be added to external static pressure before entering fan performance table.
- Interpolation is permissible. Do not extrapolate.
- Fan performance is based on wet coils, clean filters and casing losses.
- Extensive motor and drive testing on these units ensures that the full brake horsepower and watts range of the motor can be utilized with confidence. Using your fan motors up to the watts or bhp rating shown will not result in nuisance tripping or premature motor failure. Unit warranty will not be affected.
- Bold data shows the range of air flow rate for unit management system, other rpms require field-supplied drive.
- Use of field-supplied motor may affect wiring size. Contact your Carrier representative for details.
- Conversion - Bhp to KWI

$$KWI = \frac{Bhp \times 0.746}{\text{Motor efficiency}}$$

Fan Performance Table - 7 (cont)

Unit - 50TJM-26

Air Flow Rate (CFM)	Available External Static Pressure (in. wg)														
	0.2			0.4			0.6			0.8			1.0		
	RPM	KWI	BHP	RPM	KWI	BHP	RPM	KWI	BHP	RPM	KWI	BHP	RPM	KWI	BHP
4000	535	1.06	1.21	592	1.27	1.45	647	1.50	1.71	700	1.75	2.00	755	2.02	2.31
4500	564	1.30	1.49	618	1.53	1.75	669	1.77	2.03	718	2.03	2.32	766	2.29	2.62
5000	596	1.59	1.82	643	1.82	2.09	692	2.07	2.37	738	2.34	2.68	788	2.63	3.01
5500	625	1.92	2.19	671	2.16	2.47	715	2.43	2.78	759	2.70	3.09	801	2.99	3.43
6000	656	2.28	2.61	698	2.54	2.91	740	2.82	3.22	788	3.10	3.55	821	3.40	3.89
6500	686	2.70	3.09	726	2.97	3.40	766	3.26	3.73	804	3.55	4.06	843	3.86	4.42
7000	714	3.15	3.61	755	3.43	3.93	790	3.74	4.28	827	4.04	4.63	864	4.37	5.00
7500	743	3.64	4.17	779	3.94	4.51	815	4.25	4.87	849	4.56	5.22	884	4.89	5.60

Unit - 50TJM-26 (cont)

Air Flow Rate (CFM)	Available External Static Pressure (in. wg)														
	1.2			1.4			1.6			1.8			2.0		
	RPM	KWI	BHP	RPM	KWI	BHP	RPM	KWI	BHP	RPM	KWI	BHP	RPM	KWI	BHP
4000	801	2.30	2.64	849	2.61	2.98	898	2.93	3.36	944	3.28	3.75	989	3.64	4.17
4500	813	2.60	2.97	859	2.90	3.32	904	3.23	3.70	948	3.58	4.10	990	3.94	4.51
5000	827	2.93	3.36	870	3.23	3.70	913	3.57	4.09	953	3.92	4.48	996	4.28	4.90
5500	843	3.30	3.77	884	3.62	4.15	924	3.96	4.53	964	4.30	4.93	1002	4.67	5.34
6000	861	3.72	4.25	900	4.05	4.64	939	4.39	5.02	976	4.74	5.43	1013	5.11	5.85
6500	880	4.19	4.79	917	4.52	5.18	954	4.87	5.57	989	5.22	5.98	1025	5.60	6.41
7000	899	4.69	5.37	935	5.04	5.76	969	5.39	6.17	1004	5.76	6.59	1038	6.14	7.03
7500	919	5.23	5.99	952	5.59	6.40	985	5.96	6.82	1017	6.32	7.24	1051	6.71	7.68

Unit - 50TJM-32

Air Flow Rate (CFM)	Available External Static Pressure (in. wg)														
	0.2			0.4			0.6			0.8			1.0		
	RPM	KWI	BHP	RPM	KWI	BHP	RPM	KWI	BHP	RPM	KWI	BHP	RPM	KWI	BHP
6000	661	2.42	2.79	704	2.69	3.11	746	2.98	3.44	787	3.29	3.79	827	3.60	4.15
6500	691	2.86	3.30	732	3.15	3.63	773	3.46	3.99	811	3.77	4.34	849	4.10	4.72
7000	723	3.36	3.87	761	3.65	4.22	798	3.96	4.57	836	4.30	4.95	872	4.64	5.35
7500	754	3.90	4.50	791	4.22	4.86	826	4.55	5.25	860	4.88	5.63	896	5.23	6.04
8000	785	4.49	5.18	819	4.83	5.57	853	5.17	5.96	887	5.52	6.37	920	5.89	6.79
8500	814	5.13	5.92	846	5.48	6.32	879	5.83	6.72	910	6.19	7.14	943	6.57	7.58
9000	843	5.83	6.72	875	6.19	7.14	905	6.56	7.56	936	6.93	8.00	966	7.32	8.44

Unit - 50TJM-32 (cont)

Air Flow Rate (CFM)	Available External Static Pressure (in. wg)														
	1.2			1.4			1.6			1.8			2.0		
	RPM	KWI	BHP	RPM	KWI	BHP	RPM	KWI	BHP	RPM	KWI	BHP	RPM	KWI	BHP
6000	867	3.94	4.55	906	4.28	4.94	945	4.65	5.36	983	5.02	5.79	1020	5.41	6.24
6500	887	4.44	5.12	924	4.79	5.53	961	5.16	5.95	996	5.53	6.38	1032	5.93	6.84
7000	908	4.99	5.76	944	5.36	6.18	970	5.73	6.61	1012	6.12	7.05	1046	6.51	7.51
7500	930	5.60	6.46	964	5.97	6.89	997	6.36	7.34	1029	6.75	7.78	1062	7.16	8.25
8000	952	6.25	7.21	985	6.64	7.65	1017	7.03	8.11	1049	7.44	8.58	1080	7.86	9.07
8500	973	6.96	8.02	1004	7.34	8.47	1035	7.75	8.94	1065	8.16	9.41	1095	8.59	9.91
9000	996	7.72	8.90	1026	8.12	9.36	1055	8.54	9.84	1085	8.97	10.34	1114	9.40	10.84

Legend & Notes:

RPM - Revolutions Per Minute

KWI - Kilo Watts Input to Motor

Bold, Italics - Standard Motor and Drive Package

BHP - Brake Horsepower Input to Fan

CFM - Cubic Feet per Minute

in.wg - Inch Water Gauge

1. Do not adjust motor rpm such that motor maximum bhp and/or watts is exceeded at the maximum operatin cfm.

2. Static Pressure (i.e Filters) must be added to external static pressure before entering fan performance table.

3. Interpolation is permissible. Do not extrapolate.

4. Fan performance is based on wet coils, clean filters and casing losses.

5. Extensive motor and drive testing on these units ensures that the full brake horsepower and watts range of the motor can be utilized with confidence. Using your fan motors up to the watts or bhp rating shown will not result in nuisance tripping or premature motor failure. Unit warranty will not be affected.

6. Bold data shows the range of air flow rate for unit management system, other rpms require field-supplied drive.

7. Use of field-supplied motor may affect wiring size. Contact your Carrier representative for details.

8. Conversion - Bhp to KWI

$$KWI = \frac{Bhp \times 0.746}{\text{Motor efficiency}}$$

Cooling Charging Chart

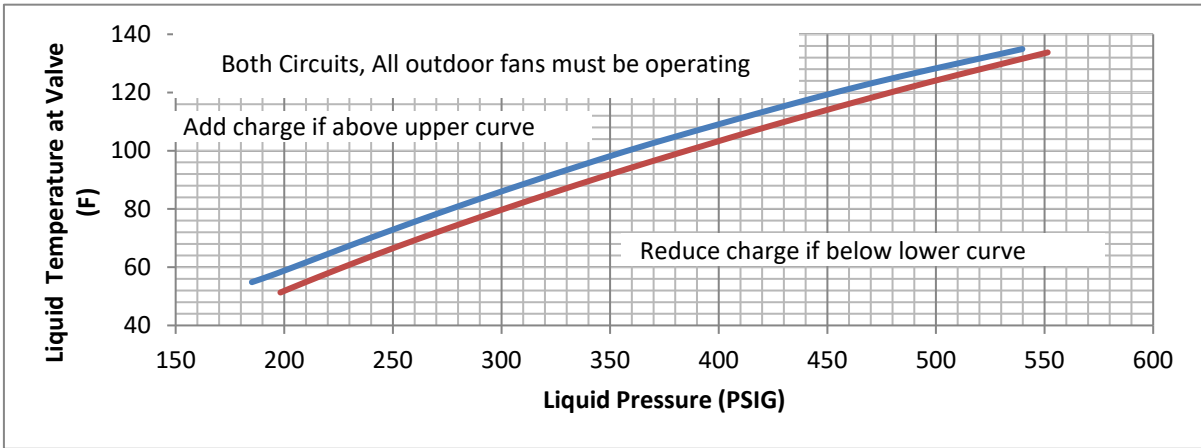

Fig - 10 Cooling Charging Charts for 50TJM Size 18

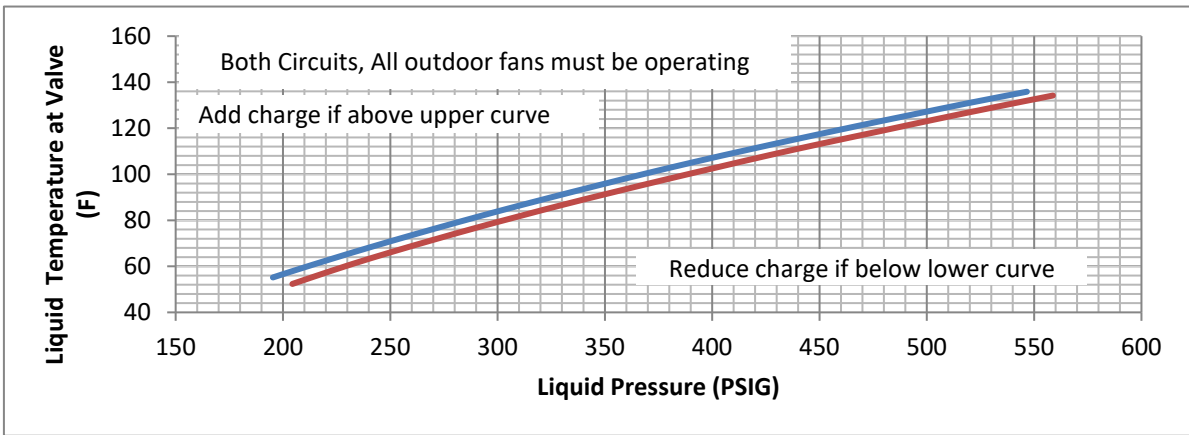

Fig - 11 Cooling Charging Charts for 50TJM Size 22

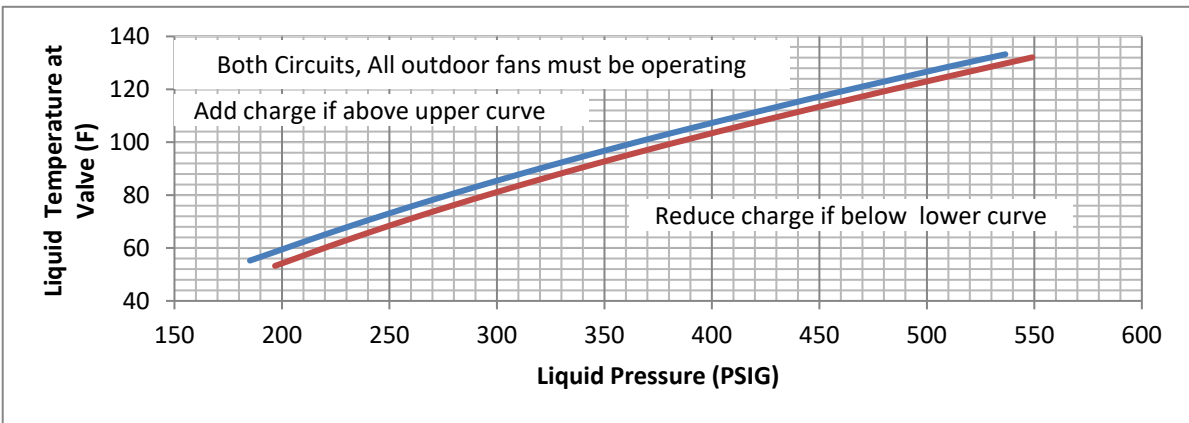

Fig - 12 Cooling Charging Charts for 50TJM Size 26

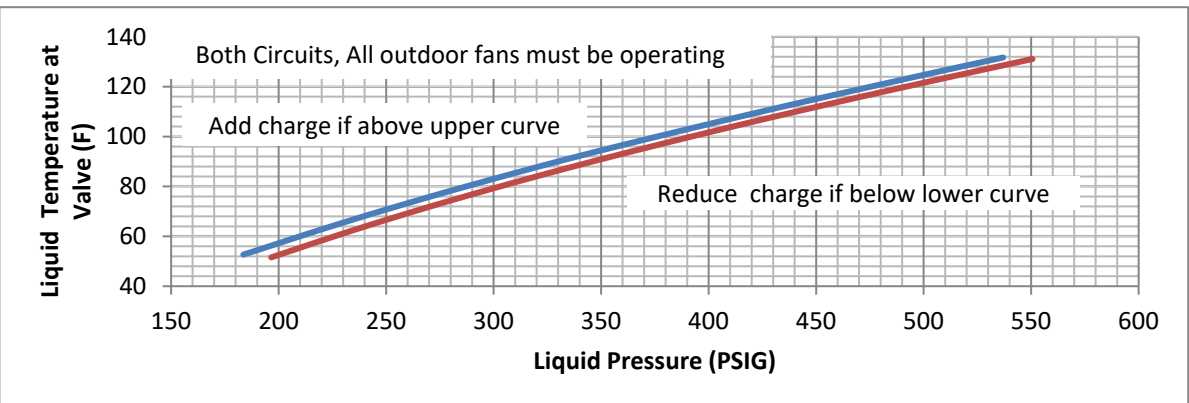

Fig - 13 Cooling Charging Charts for 50TJM Size 32

Troubleshooting Guide

Table 8 — Cooling Service Analysis

PROBLEM	CAUSE	REMEDY
Compressor and condenser fan will not start.	Power failure.	Call power company.
	Fuse blown or circuit breaker tripped.	Replace fuse or reset circuit breaker.
	Defective thermostat, contactor, transformer, or control relay.	Replace component.
	Insufficient line voltage.	Determine cause and correct.
	Incorrect or faulty wiring.	Check wiring diagram and rewire correctly.
	Thermostat setting too high.	Lower thermostat setting below room temperature.
Compressor will not start but condenser fan runs.	Faulty wiring or loose connections in compressor circuit.	Check wiring and repair or replace.
	Compressor motor burned out, seized, or internal overload open.	Determine cause. Replace compressor.
	Defective overload.	Determine cause and replace.
	Compressor locked out	Determine cause for safety trip and reset lockout.
	One leg of 3-phase power dead.	Replace fuse or reset circuit breaker. Determine cause.
Compressor cycles (other than normally satisfying thermostat).	Refrigerant overcharge or undercharge.	Recover refrigerant, evacuate system, and recharge to nameplate.
	Defective compressor.	Replace and determine cause.
	Insufficient line voltage.	Determine cause and correct.
	Blocked condenser.	Determine cause and correct.
	Defective overload.	Determine cause and replace.
	Defective thermostat.	Replace thermostat.
	Faulty condenser-fan motor.	Replace.
	Restriction in refrigerant system.	Locate restriction and remove.
Compressor operates continuously.	Dirty air filter.	Replace filter.
	Unit undersized for load.	Decrease load or increase unit size.
	Thermostat set too low.	Reset thermostat.
	Low refrigerant charge.	Locate leak, repair, and recharge.
	Air in system.	Recover refrigerant, evacuate system, and recharge.
	Condenser coil dirty or restricted.	Clean coil or remove restriction.
Excessive head pressure.	Dirty drier filter.	Replace filter.
	Dirty condenser coil.	Clean coil.
	Refrigerant overcharged.	Recover excess refrigerant.
	Faulty TXV.	1. Check TXV bulb mounting and secure tightly to suction line. 2. Replace TXV if stuck open or closed.
	Air in system.	Recover refrigerant, evacuate system, and recharge.
	Condenser air restricted or air short-cycling.	Determine cause and correct.
Head pressure too low.	Low refrigerant charge.	Check for leaks, repair, and recharge.
	Restriction in liquid tube.	Remove restriction.
Excessive suction pressure.	High heat load.	Check for source and eliminate.
	Faulty TXV.	1. Check TXV bulb mounting and secure tightly to suction line. 2. Replace TXV if stuck open or closed.
	Refrigerant overcharged.	Recover excess refrigerant.
Suction pressure too low.	Dirty air filter.	Replace filter.
	Low refrigerant charge.	Check for leaks, repair, and recharge.
	Metering device or low side restricted.	Remove source of restriction.
	Faulty TXV.	1. Check TXV bulb mounting and secure tightly to suction line. 2. Replace TXV if stuck open or closed.
	Insufficient evaporator airflow.	Increase air quantity. Check filter and replace if necessary.
	Temperature too low in conditioned area.	Reset thermostat.
Field-installed filter drier restricted.	Replace.	

START-UP CHECKLIST

(Remove and Store in Job File)

I. PRELIMINARY INFORMATION

MODEL NO: _____ DATE: _____

SERIAL NO: _____ TECHNICIAN: _____

II. PRE-START-UP (Insert checkmark in box as each item is completed)

- 1) ALL PACKING MATERIALS HAVE BEEN REMOVED FROM THE UNIT.
- 2) VERIFY THAT UNIT INSTALLATION IS LEVEL.
- 3) CONDENSATE CONNECTION IS INSTALLED PER INSTALLATION INSTRUCTION.
- 4) UNIT GROUNDING WIRE HAS BEEN CONNECTED.
- 5) POWER WIRES HAVE BEEN SIZED AND INSTALLED PROPERLY TO THE UNIT.
- 6) CONTROL WIRING CONNECTIONS HAVE BEEN INSTALLED PROPERLY.
- 7) CHECK ALL WIRING TERMINALS HAVE BEEN TIGHTENED PROPERLY.
- 8) ENERGIZE CRANKCASE HEATERS FOR 12 HOURS.
- 9) CORRECT FAN ROTATION HAS BEEN CONFIRMED.
- 10) SEALED ALL POWER AND CONTROL WIRES ENTRY INTO THE UNIT AND INSIDE THE BOX

III. START - UP

ELECTRICAL:

SUPPLY VOLTAGE: (L1 - L2): _____ (L2 - L3): _____ (L3 - L1): _____

COMPRESSOR - 1 AMPS: (L1): _____ (L2): _____ (L3): _____

COMPRESSOR - 2 AMPS: (L1): _____ (L2): _____ (L3): _____

INDOOR FAN AMPS: (L1): _____ (L2): _____ (L3): _____

TEMPERATURES: (BOTH CIRCUITS OPERATING)

OUTDOOR AIR: _____ : DB

INDOOR SECTION ENTERING AIR: _____ : DB _____ : WB

INDOOR SECTION LEAVING AIR: _____ : DB _____ : WB

PRESSURES:

CIRCUIT - 1

REFRIGERANT SUCTION _____ :PSIG REFRIGERANT DISCHARGE _____ :PSIG

CIRCUIT - 2

REFRIGERANT SUCTION _____ :PSIG REFRIGERANT DISCHARGE _____ :PSIG

VERIFY REFRIGERANT CHARGE USING CHARGING CHART IN FIG - 10 to FIG - 13

Notes:

(Tear Along This Line)

NOTES

NOTES

