



Quality Assurance
Certificate Reg. No:
04 100 950420



Subject to change without notice
Manufacturing point: Jeddah, Saudi Arabia
Nearest port of embarkation: Jeddah Islamic port
Product classification: Commercial

Product Data Catalog

50TCM – 50Hz **Nominal Cooling Capacity 6.0 – 11.0 Tons** **HFC R-410A Refrigerant**

The 50TCM units are single side discharge rooftop cooling unit utilizing electric heat as an option. Units are pre-wired, pre-charged with R-410A refrigerant, and tested at the factory. These units can be placed on the side of a building or can be placed on a roof without roof curbs. Each unit is designed to occupy a minimal space. Piping and drain connections are readily accessible.

Contact your local Carrier representative for additional reference materials.

Table of Contents

Features / Benefits.....	2
Shipping Information / Options / Accessories.....	4
Model No. Nomenclature	6
AHRI Capacity Ratings.....	7
Physical Data.....	8
Unit Dimensional Drawing	10
Cooling Capacities	16
Fan Performance Table	21
Fan RPM at Motor Pulley / Sound Rating	24
Electrical Data / Electric Heater Data	25
Wiring Schematic.....	27
Application Data.....	37
Guide Specifications	38

Features / Benefits

Every compact one-piece unit arrives fully assembled, charged, tested, and ready to run.

Durable-Dependable Construction

Designed for durability in any climate, the weather-resistant cabinets are constructed of galvanized steel, bonderized, and all exterior panels are coated with a pre-painted baked enamel finish. The paint finish is non-chalking, and is capable of withstanding ASTM (American Society for Testing and Materials) B117 500-hour Salt Spray Test. All internal cabinet panels are primed, permitting longer life and a more attractive appearance for the entire unit. Totally enclosed condenser-fan motor and permanently lubricated bearings provide additional unit dependability.

Indoor-Air Quality

Non corrosive sloped condensate pans minimize biological growth in rooftop units in accordance with ASHRAE (American Society of Heating, Refrigeration and Air Conditioning Engineers) Standard 62-99 (IAQ). 2"inch filters provide for greater particle reduction in the return air.

Simple, Electrical Connections

Terminal boards, located in the unit control box, facilitate connections to room thermostat, outdoor thermostat(s) and electric heater. Service panels can be quickly removed, permitting easy servicing. Both power and control connections are made on the same side of the unit to simplify installation. In addition, color-coded wires permit easy tracing and diagnostics.

Easy Installation

All units feature base rail design with forklift slots and rigging holes for easier maneuvering. Durable packaging protects all units during shipment and storage. Convenient side by side openings permit installation very close to face of buildings or on roof top. The non-corrosive sloped condensate pan minimizes residual condensate in off cycle. An external, field-supplied P-trap is required. Field-installed electric heaters are available up to 34.7 kW.

Installation Features

- Single point electrical service entry
- Side discharge application
- No roof curb needed
- Side-by-side supply and return air
- Separate panel for control box

Performance Features

- HFC R-410A non-ozone depleting refrigerant
- ASHRAE 90.1 Compliant
- EER's up to 11.8
- TXV refrigerant metering device for Size 07 & 08, Acutrol metering device for Size 09 to 13
- Two independent refrigerant circuits, each with a scroll compressor
- Low outdoor temperature cooling operation down to 40° F
- Liquid filter drier standard on each circuit
- Fresh air intake capable up-to 10% through return duct
- Non-corrosive sloped condensate drain pan in accordance to ASHRAE 62 standard
- Thermally protected and permanently lubricated condenser and evaporator fan motors

Environmentally Sound Refrigerant Choice

R410A refrigerant is:

- A chlorine-free refrigerant from the HFC group
- Has zero ozone depletion potential
- Thermally efficient and provides high EER (energy efficiency), COP, and part load efficiencies

Superior Reliability, Efficiency and Safety

- Exceptional endurance tests
 - Painted panels tested to ASTM B-117 500 hours salt spray protection
 - Pre-coated fin condenser coil for extra corrosion protection
- Compressor Protection:
 - High and low pressure cutouts
 - Phase protection relay
 - Crankcase heaters are standard for all units
 - Internal over temperature protection
 - Freeze protection
- Low vibration design:
 - Leak-tight refrigerant circuit
 - Brazed refrigerant connections for increased leak tightness
 - Low-noise scroll compressors with low vibration levels
- Control circuit protected by circuit breaker
- Thermally protected and permanently lubricated condenser and evaporator fan motors
- Transformer for safe 24V control circuit supply included
- High Efficiency, High Static Blower
- State-of-art scroll compressor technology
- Dual, electrically and mechanically independent refrigerant circuit
- Single skin construction, insulated cabinet

Shipping Information

Unit data with Condenser and Evaporator Al/Cu, Condenser Precoat Al/Cu and Evaporator Al/Cu Coils¹

Unit Model Number	EST. WT. (KG)		DIMENSIONS (MM)					
			Net			With Wooden create above		
	NET	GROSS (with Skid)	LENGTH	WIDTH	HEIGHT	LENGTH	WIDTH	HEIGHT
50TCMA07A9X1-0A0A0	275	285	1888	1187	1051	1943	1219	1089
50TCMD08A9X1-0A0A0	345	360	2238	1510	1048	2292	1543	1207
50TCMD09A9X1-0A0A0	388	403	2238	1510	1253	2292	1543	1412
50TCMD12A9X1-0A0A0	393	408	2238	1510	1253	2292	1543	1412
50TCMD13A9X1-0A0A0	489	504	2238	1510	1253	2292	1543	1412

Unit data with Condenser Only Cu/Cu Coils¹

Unit Model Number	EST. WT. (KG)		DIMENSIONS (MM)					
			Net			With Wooden create above		
	NET	GROSS (with Skid)	LENGTH	WIDTH	HEIGHT	LENGTH	WIDTH	HEIGHT
50TCMA07A9E1-0A0A0	310	320	1888	1187	1051	1943	1219	1089
50TCMD08A9E1-0A0A0	379	394	2238	1510	1048	2292	1543	1207
50TCMD09A9E1-0A0A0	430	445	2238	1510	1253	2292	1543	1412
50TCMD12A9E1-0A0A0	434	449	2238	1510	1253	2292	1543	1412
50TCMD13A9E1-0A0A0	530	545	2238	1510	1253	2292	1543	1412

Unit data with Condenser and Evaporator Cu/Cu Coils¹

Unit Model Number	EST. WT. (KG)		DIMENSIONS (MM)					
			Net			With Wooden create above		
	NET	GROSS (with Skid)	LENGTH	WIDTH	HEIGHT	LENGTH	WIDTH	HEIGHT
50TCMA07A9F1-0A0A0	331	341	1888	1187	1051	1943	1219	1089
50TCMD08A9F1-0A0A0	398	413	2238	1510	1048	2292	1543	1207
50TCMD09A9F1-0A0A0	461	476	2238	1510	1253	2292	1543	1412
50TCMD12A9F1-0A0A0	465	480	2238	1510	1253	2292	1543	1412
50TCMD13A9F1-0A0A0	561	576	2238	1510	1253	2292	1543	1412

Factory Installed Options and Field Installed Accessories

Category	Item Description	Factory Installed Option	Field Installed Accessory
Coil Options	Cu/Cu indoor and/or outdoor coils ¹	X	
	Pre-coated outdoor coils ¹	X	
Indoor Motor & Drive	Multiple motor and drive packages ¹	X	
Sight glass	Refrigerant sight glass installed on each circuit ¹	X	
Condenser Protection	Condenser coil hail guard (louvered design)		X
Controls	Thermostats, temperature sensors, and subbases		X
	RTU Open – protocol controller		X
	Time Guard II compressor delay control circuit		X
	Smoke detector (supply and return)		X
Electric Heat	Electric Resistance Heaters		X
	Single Point Kit		X
Low Ambient Control	Winter start kit ²		X
	Motormaster head pressure control		X

NOTES:

1. Please refer to product nomenclature for ordering information.
2. See application data for assistance.

Factory Options and Accessories

RTU Open, Multi-protocol Controller

Connect the rooftop to an existing BAS without complicated translators or adapter modules using the RTU Open controller. This new controller speaks the 4 most common building automation system languages (BACNET, Modbus, Johnson N2, and LonWorks). Use this controller when you have an existing BAS.

Time Guard II Control Circuit

This accessory protects your compressor by preventing short-cycling in the event of some other failure, prevents the compressor from restarting for 30 seconds after stopping. Not required with RTU Open, or authorized commercial thermostats.

Filter or Fan Status Switches

Use these differential pressure switches to detect a filter clog or indoor fan motor failure. When used in conjunction with a compatible unit controller/thermostat, the switches will activate an alarm to warn the appropriate personnel.

Winter Start Kit

The winter start kit by Carrier extends the low ambient limit of your rooftop to 25°F (-4°C). The kit by-passes the low pressure switch, preventing nuisance tripping of the low pressure switch. Other low ambient precautions may still be prudent.

Alternate Motors and Drives

Some applications need larger horsepower motors, some need more airflow, and some need both. Regardless of the case, your Carrier expert has a factory installed combination to meet your application. A wide selection of motors and pulleys (drives) are available, factory installed, to handle nearly any application.

Electric Heaters

Carrier offers a full-line of field-installed accessory heaters. The heaters are very easy to use, install and are all pre-engineered and certified.

Model Number Nomenclature - 50TCM - R410A Series

1	2	3	4	5	6	7	8	9	10	11	12	13	14	15	16	17	18
5	0	T	C	M	A	0	7	A	9	A	1	-	0	A	0	A	0

Unit Heat Type
50 = Cooling /
Electric Heat RTU

Model Series - Desert Master
TCM = High Ambient Application

Refig. System Options
A = Standard 1 - Stage Cooling
D = Standard 2 - Stage Cooling Models 08-14

Nominal Ton
07 = 6.0 Ton
08 = 7.5 Ton
09 = 8.5 Ton
12 = 10.0 Ton
13 = 11.0 Ton

Sensor Options
A = None

Power Supply (V/Ph/Hz)
9 = 400/3/50

Design Review
- = Factory Assigned

Indoor Fan Options
1 = Standard Static Option
2 = Medium Static Option

Coil Options (Outdoor - Indoor)
A = Al/Cu - Al/Cu
B = Precoat Al/Cu - Al/Cu
E = Cu/Cu - Al/Cu
F = Cu/Cu - Cu/Cu

Brand/Packaging
0 = Standard

Electrical Options
A = None

Service Options
0 = None
1 = Sight Glass

Design Series
A = Series A
B = Series B

Base Unit Controls
0 = Electromechanical Controller

AHRI Capacity Rating

Unit 50TCM	Nominal Ton	Standard CFM	Net Cooling Capacity (BTU/hr)	Net Cooling Capacity (Watt)	Net Cooling Capacity (Ton)	EER	Standard m3/hr	Standard L/s
A07	6.0	2400	64250	18831	5.4	11.8	4075	1133
D08	7.5	3000	84750	24839	7.1	11.8	5094	1416
D09	8.5	3200	92000	26964	7.7	11.8	5436	1510
D12	10.0	4000	110500	32386	9.2	11.6	6792	1888
D13	11.0	3500	128500	37661	10.7	11.6	5947	1652

Minimum - Maximum Air Flow Rate

Unit 50TCM	Minimum	Maximum	Minimum	Maximum
	CFM	CFM	L/s	L/s
A07	1800	2850	849	1345
D08	2250	3750	1062	1770
D09	2550	4250	1203	2006
D12	3000	4500	1416	2124
D13	3000	4600	1416	2171

Minimum Electric Heating Air Flow Rate

Unit 50TCM	Unit Voltage	Heater kW	Unit Configuration	Minimum	Minimum
				CFM	L/s
A07	400	All	Horizontal	1800	849
D08	400	All	Horizontal	2250	1062
D09	400	All	Horizontal	2250	1062
D12	400	All	Horizontal	3000	1416
D13	400	All	Horizontal	3000	1416

EER - Energy Efficiency Ratio

CFM - Cubic Feet per Minute

L/s - Liters per Second

BTU - British Thermal Unit

*AHRI - Air Conditioning, Heating and Refrigeration Institute.

1. Rated in accordance with AHRI Standards 340/360.
2. Ratings are net values, reflecting the effects of circulating fan heat.
3. Cooling Standard: 80 F db, 67 wb indoor entering-air temperature and 95 F db air entering outdoor unit.

Unit Physical Data (English)

Unit 50TCM	A07	D08	D09	D12	D13
Unit Dimensions - (in)	41.3x74.3x46.7	41.2x88.1x59.4	49.3x88.1x59.4		
Unit Operating Weight - (LBS)	606	761	865	904	1076
Refrigeration System					
Compressor No.# / Type	1 / Scroll		2 / Scroll		
Refrigerant type	Puron ® R410A				
Circuits No.#	1		2		
Charge per Circuit (1-Down/2-Up) - (LBS)	15.33	8.71/ 7.05	8.77/9.8	11.6/11.51	13.01/12.79
Metering Device	TXV		Acutrol		
Filter Drier Qty	1		2		
High Pressure Switch (Trip/ Reset) - (PSIG)	630 / 505				
Low Pressure Switch (Trip/ Reset) - (PSIG)	54 / 117				
Condenser Coil					
Coil Type	Helical Grooved Copper Tube, Aluminum DW fins.				
Standard Coil Material	Cu/Al				
Rows / FPI	2 / 17			3 / 17	
Face Area (ft ²)	21.3	20.5	25.1		
Coil test Pressure (PSIG)	450				
Condenser Fan & Motor					
Approx. Air Flow Rate (CFM)	5000	6400	7800	9200	
Quantity	1	2	1		
Diameter (in) / No. of Blades	26/3	22/3	30/4	30/3	
Motor Type	Totally Enclosed				
Motor HP - RPM	1/3 - 1430	1/3 - 1200	1-950	1 - 835	
Evaporator Coil					
Coil Type	3/8" Helical Grooved Copper Tube, 0.75" Aluminum LSW Fins.				
Standard Coil Material	Cu/Al				
Rows / FPI	4/15	4/15			
Face Area (ft ²)	7.3	8.9	11.1		
Coil test Pressure (PSIG)	350				
Drain Pan connection Size (in)	3/4				
Return Air Filter Qty/ Size (in)	4 / 16x16x2	4 / 16x20x2	4 / 20x20x2		
Evaporator Fan & Motor section					
Fan Quantity / Fan Size (in)	1 / 10 x 10		1 / 15 x 15		
Fan Type	Centrifugal - Forward Blade				
Drive Type	Belt				
Motor Type	Open Drip Proof				
Standard Static Drive					
Motor Qty	1				
Maximum BHP	1.4	2		2.4	
FLA	2.6			3.4	
Efficiency @ Full Load	80%			81%	
RPM Range	855 - 1211	570 - 808		665 - 903	
Shaft Diameter (in)	5/8			7/8	
Motor Frame Size	56Y				
Medium Static Drive					
Motor Qty	1				
Maximum BHP	2.4		3.1	3.9	
FLA	3.4		4.4	7.4	
Efficiency @ Full Load	81%				
RPM Range	1077 - 1449	692 - 932	808 - 1082	837 - 1056	
Shaft Diameter (in)	7/8				
Motor Frame Size	56Y		56HZ	145TY	

Unit Physical Data (SI)

Unit 50TCM	A07	D08	D09	D12	D13
Unit Dimensions - (mm)	1051x1888x1187	1048x2238x1510	1253x2238x1510		
Unit Operating Weight - (kG)	275	345	393	410	489
Refrigeration System					
Compressor No.# / Type	1 / Scroll		2 / Scroll		
Refrigerant type	Puron ® R410A				
Circuits No.#	1		2		
Charge per Circuit (1-Down/2-Up) - (kG)	6.97	3.40 / 3.20	3.98 / 4.12	5.26 / 5.22	5.90 / 5.80
Metering Device	TXV		Acutrol		
Filter Drier Qty	1		2		
High Pressure Switch (Trip/ Reset) - (bar)	43 / 34				
Low Pressure Switch (Trip/ Reset) - (bar)	4 / 8				
Condenser Coil					
Coil Type	Helical Grooved Copper Tube, Aluminum DW Fins.				
Standard Coil Material	Cu / Al				
Rows / FPI	2 / 17			3 / 17	
Face Area (m ²)	1.98	1.90	2.33		
Coil test Pressure (bar)	31				
Condenser Fan & Motor					
Approx. Air Flow Rate (m ³ /hr)	8492	10867	13244	15622	
Quantity	1	2	1		
Diameter (mm) / No. of Blades	660 / 3	559 / 3	762 / 4	762 / 3	
Motor Type	Totally Enclosed				
Motor HP - RPS	1/3 - 24	1/3 - 20	1 - 16	1 - 14	
Evaporator Coil					
Coil Type	3/8" Helical Grooved Copper Tube, 0.75" Aluminum LSW Fins.				
Standard Coil Material	Cu/Al				
Rows / FPI	4 / 15		4 / 15		
Face Area (m ²)	0.7	0.8	1.0		
Coil test Pressure (bar)	23.8				
Drain Pan Connection Size (mm)	19				
Return Air Filter Qty x Size (mm)	4 / 406.4 x 406.4 x 50.8	4 / 406.4 x 508 x 50.8	4 / 508 x 508 x 50.8		
Evaporator Fan & Motor section					
Fan Quantity / Fan Size (mm)	1 / 254 x 254		1 / 381 x 381		
Fan Type	Centrifugal - Forward Blade				
Drive Type	Belt				
Motor Type	Open Drip Proof				
Standard Static Drive					
Motor Qty	1				
Maximum kW	1.0	1.5		1.8	
FLA	2.6			3.4	
Efficiency @ Full Load	80%			81%	
RPS Range	14.3 - 20.2	9.5 - 13.5		11.1 - 15.1	
Shaft Diameter (mm)	15.9			22.2	
Motor Frame Size	56Y				
Medium Static Drive					
Motor Qty	1				
Maximum kW	1.8		2.3	2.9	
FLA	3.4		4.4	7.4	
Efficiency @ Full Load	81%				
RPS Range	18.0 - 24.1	11.5 - 15.5		13.5 - 18.0	14.0 - 17.6
Shaft Diameter (mm)	22.2				
Motor Frame Size	56Y			56HZ	145TY

CURBS & WEIGHTS DIMENSIONS - 50TCM07

NOTES:

1. DIMENSIONS ARE IN INCHES, DIMENSIONS IN () ARE IN MILLIMETERS.
2. CENTER OF GRAVITY
3. DIRECTION OF AIR FLOW

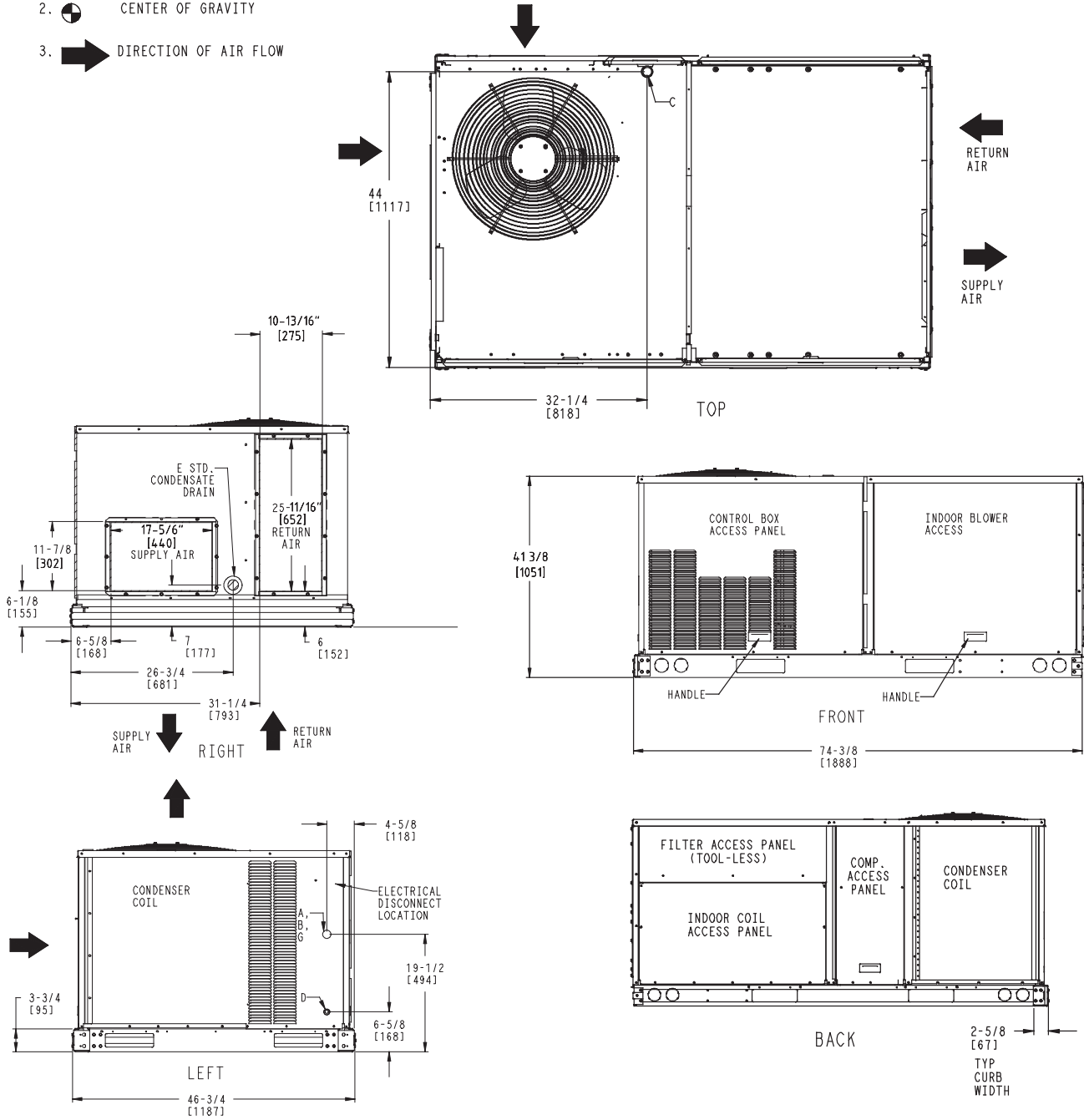

CONNECTION SIZES	
A	1 3/8" DIA [35] FIELD POWER SUPPLY HOLE
B	2" DIA [51] POWER SUPPLY KNOCKOUT
C	1 3/4" DIA [44] GAUGE ACCESS PLUG
D	7/8" DIA [22] FIELD CONTROL WIRING HOLE
E	3/4"-14 NPT CONDENSATE DRAIN
G	2 1/2" DIA [64] POWER SUPPLY KNOCK-OUT

Dimensions 50TCMA07

CURBS & WEIGHTS DIMENSIONS - 50TCM07 (cont.)

UNIT	STD. UNIT WEIGHT		CORNER WEIGHT (A)		CORNER WEIGHT (B)		CORNER WEIGHT (C)		CORNER WEIGHT (D)		C.G.		HEIGHT
	LBS.	KG.	LBS.	KG.	LBS.	KG.	LBS.	KG.	LBS.	KG.	X	Y	Z
50TCMA07	607	275	150	68	160	73	153	69	144	65	38 [965]	22 [559]	20 3/4 [527]

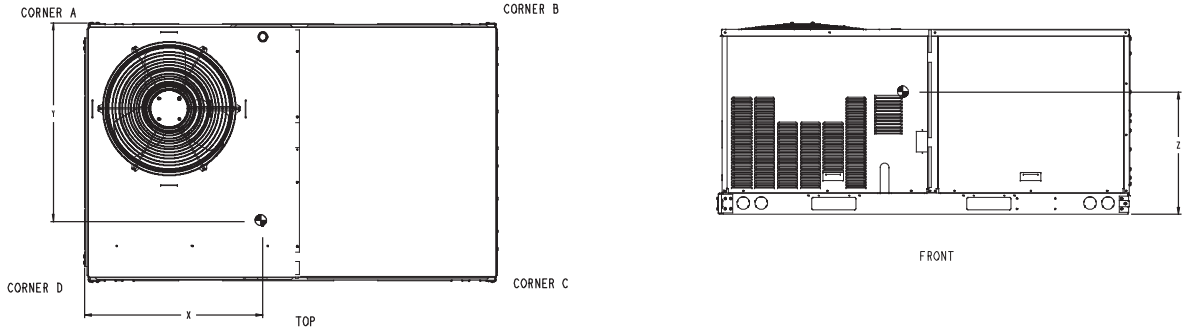

Dimensions 50TCMA07

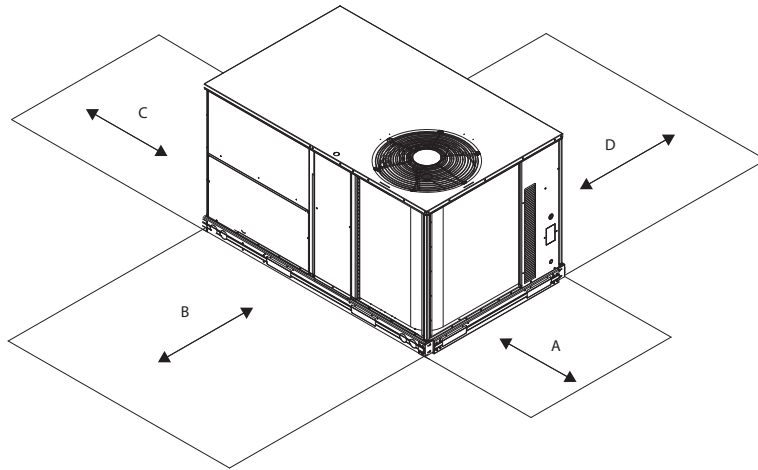

Service Clearance

LOC	DIMENSION	CONDITION
A	48-in (1219 mm) 18-in (457 mm) 18-in (457 mm) 12-in (305 mm)	Unit disconnect is mounted on panel No disconnect, convenience outlet option Recommended service clearance Minimum clearance
B	42-in (1067 mm) 36-in (914 mm)	Surface behind servicer is grounded (e.g., metal, masonry wall) Surface behind servicer is electrically non-conductive (e.g., wood, fiberglass)
C	36-in (914 mm) 18-in (457 mm)	Side condensate drain is used Minimum clearance
D	42-in (1067 mm) 36-in (914 mm)	Surface behind servicer is grounded (e.g., metal, masonry wall, another unit) Surface behind servicer is electrically non-conductive (e.g., wood, fiberglass)

CURBS & WEIGHTS DIMENSIONS - 50TCMD08

NOTES:

1. DIMENSIONS ARE IN INCHES, DIMENSIONS IN () ARE IN MILLIMETERS.

2. CENTER OF GRAVITY

3. DIRECTION OF AIR FLOW

CONNECTION SIZES	
A	1 3/8" DIA [35] FIELD POWER SUPPLY HOLE
B	2 1/2" [64] DIA POWER SUPPLY KNOCKOUT
C	1 3/4" DIA [51] GAUGE ACCESS PLUG
D	7/8" DIA [22] FIELD CONTROL WIRING HOLE
E	3/4"-14 NPT CONDENSATE DRAIN
G	2 " DIA [51] POWER SUPPLY KNOCK-OUT

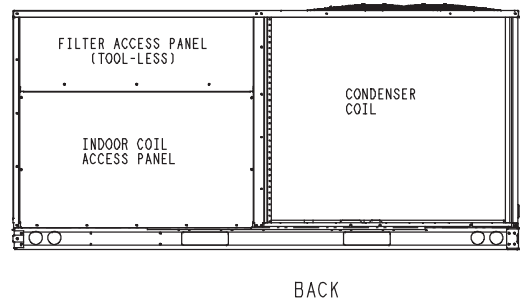
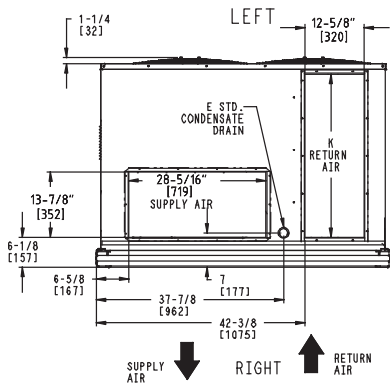
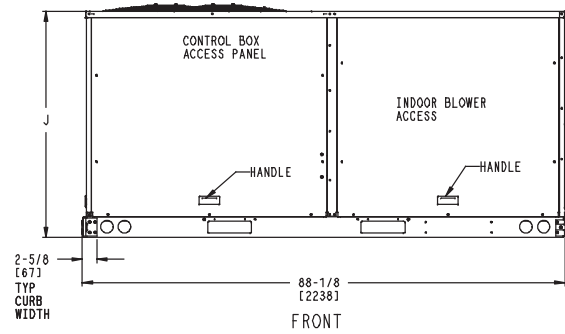
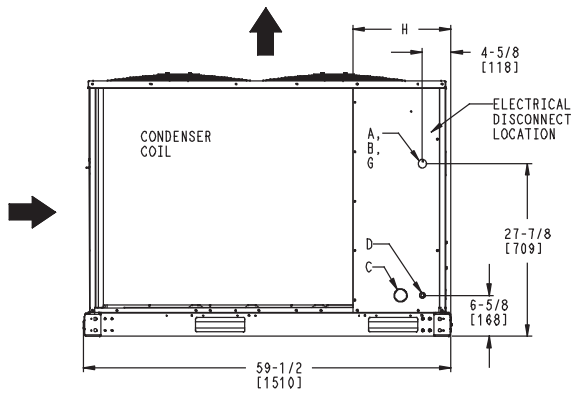
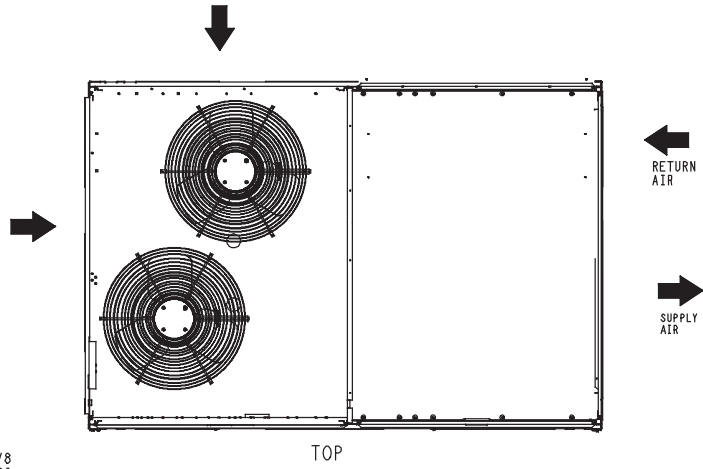

UNIT	OUTDOOR COIL TYPE	J	K	H
50TCMD08	RTPF	41 1/4 [1048]	33 11/16" [856]	15 7/8 [403]
RTPF - ROUND TUBE, PLATE FIN (COPPER/ALUM)				

Dimensions 50TCMD08

CURBS & WEIGHTS DIMENSIONS - 50TCMD08 (cont.)

UNIT	OUTDOOR COIL TYPE	STD. UNIT WEIGHT ***		CORNER WEIGHT (A)		CORNER WEIGHT (B)		CORNER WEIGHT (C)		CORNER WEIGHT (D)		C.G.		
		LBS.	KG.	LBS.	KG.	LBS.	KG.	LBS.	KG.	LBS.	KG.	X	Y	Z
50TCMD08	RTPF	760	345	158	71.7	155	70.4	222	100.8	225	102.2	43 3/4 [1111.3]	35 [889]	20 [508]
RTPF - ROUND TUBE, PLATE FIN (COPPER/ALUM)				*** STANDARD UNIT WEIGHT IS WITHOUT ELECTRIC HEAD AND PACKAGING FOR OTHER OPTIONS AND ACCESSORIES, REFER TO PRODUCT DATA CATALOG										

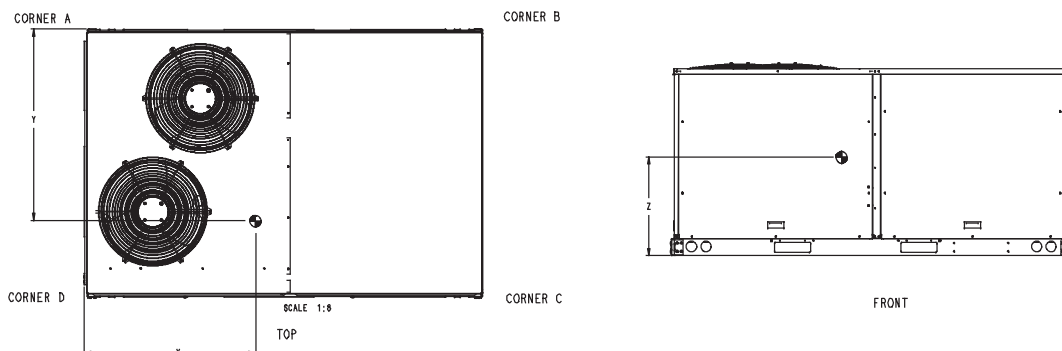

Dimensions 50TCMD08

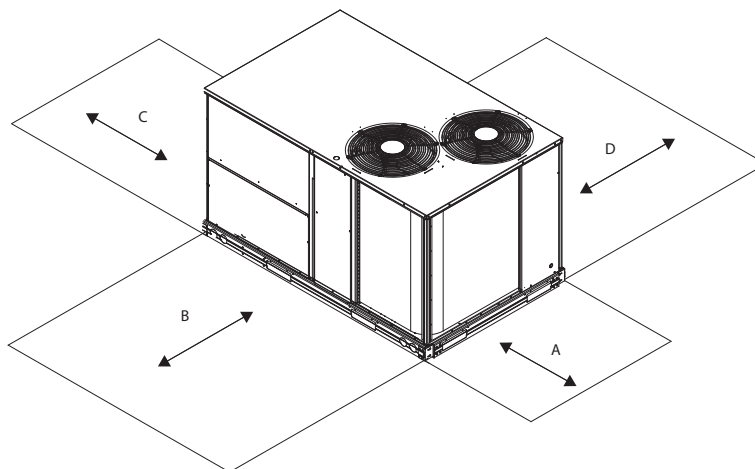

Service Clearance

LOC	DIMENSION	CONDITION
A	48-in (1219 mm)	Unit disconnect is mounted on panel
	36-in (914 mm)	If dimension-B is 12-in (305 mm)
	18-in (457 mm)	No disconnect, convenience outlet option
	18-in (457 mm)	Recommended service clearance (use electric screwdriver)
	12-in (305 mm)	Minimum clearance (use manual ratchet screwdriver)
B	12-in (305 mm)	If dimension-A is 36-in (914 mm)
C	36-in (914 mm)	Side condensate drain is used
	18-in (457 mm)	Minimum clearance
D	42-in (1067 mm)	Surface behind servicer is grounded (e.g., metal, masonry wall, another unit)
	36-in (914 mm)	Surface behind servicer is electrically non-conductive (e.g., wood, fiberglass)

CURBS & WEIGHTS DIMENSIONS - 50TCMD 09/12/13

NOTES:

1. DIMENSIONS ARE IN INCHES. DIMENSIONS IN () ARE IN MILLIMETERS.
2. CENTER OF GRAVITY
3. DIRECTION OF AIR FLOW

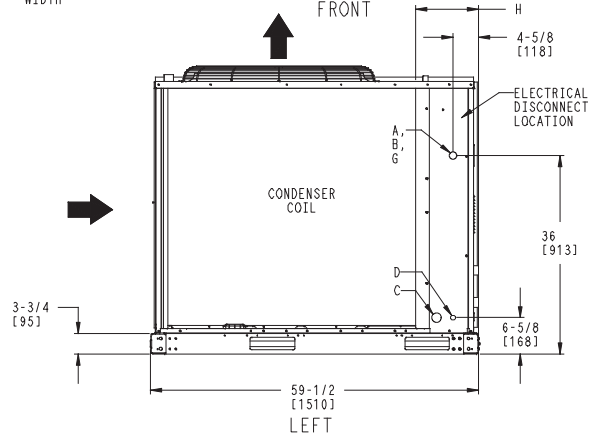
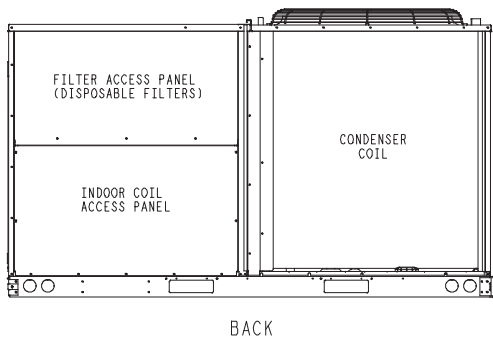
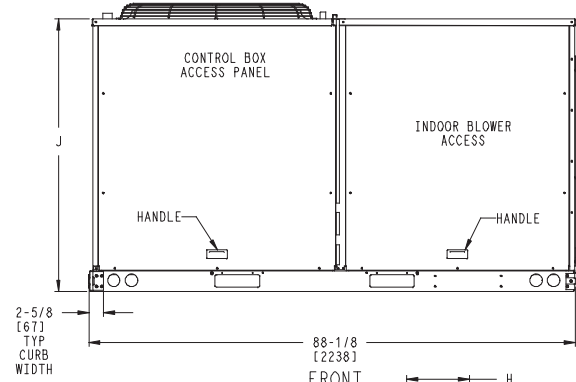
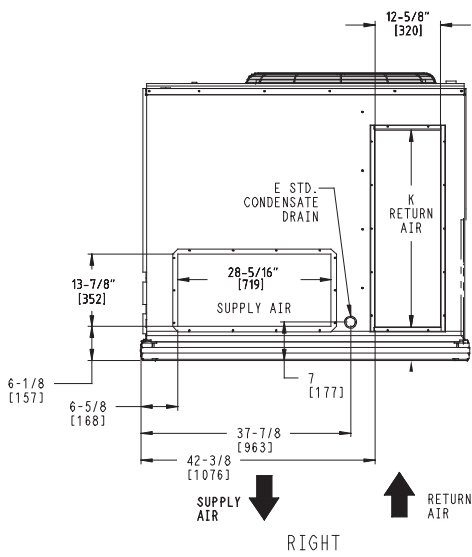
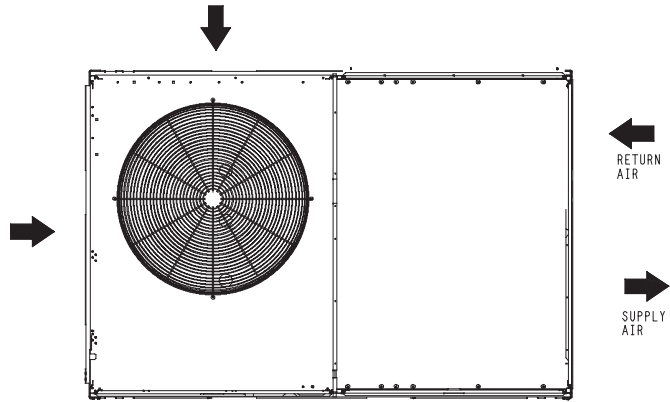

CONNECTION SIZES	
A	1 3/8" [35] DIA FIELD POWER SUPPLY HOLE
B	2 1/2" [64] DIA POWER SUPPLY KNOCKOUT
C	1 3/4" [51] DIA GAUGE ACCESS PLUG
D	7/8" [22] DIA FIELD CONTROL WIRING HOLE
E	3/4"-14 NPT CONDENSATE DRAIN
G	2" [51] DIA POWER SUPPLY KNOCK-OUT

UNIT	H	J	K
50TCMD09	11 3/8 [289]	49 3/8 [1253]	36 3/8" [924]
50TCMD12	11 3/8 [289]	49 3/8 [1253]	36 3/8" [924]
50TCMD13	11 3/8 [289]	49 3/8 [1253]	36 3/8" [924]

Dimensions 50TCMD 09/ 12 / 13

CURBS & WEIGHTS DIMENSIONS - 50TCMD 09/12/13 (cont.)

UNIT	OUTDOOR COIL TYPE	STD. UNIT WEIGHT ***		CORNER WEIGHT (A)		CORNER WEIGHT (B)		CORNER WEIGHT (C)		CORNER WEIGHT (D)		C.G.		
		LBS.	KG.	LBS.	KG.	LBS.	KG.	LBS.	KG.	LBS.	KG.	X	Y	Z
50TCMD09	RTPF	865	393	275	125	125	57	145	66	321	146	28 3/8 [721]	33 1/8 [841]	21 3/8 [543]
50TCMD12	RTPF	904	410	287	130	131	59	152	69	335	152	28 3/8 [721]	33 1/8 [841]	21 3/8 [543]
50TCMD13	RTPF	1076	489	341	155	156	71	180	82	398	181	28 3/8 [721]	33 1/8 [841]	21 3/8 [543]

*** STANDARD UNIT WEIGHT IS WITHOUT ELECTRIC HEAD AND PACKAGING
FOR OTHER OPTIONS AND ACCESSORIES, REFER TO PRODUCT DATA CATALOG

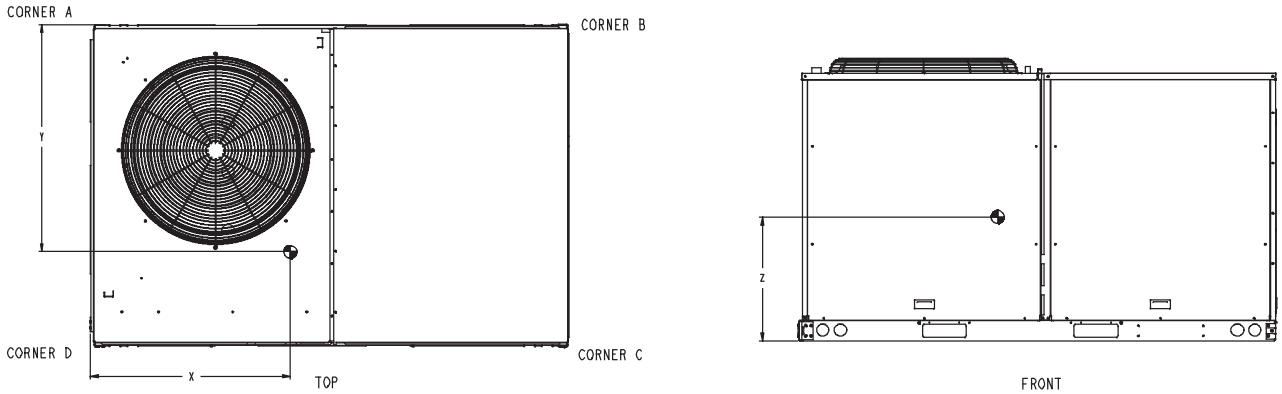

Dimensions 50TCMD 09/12/13

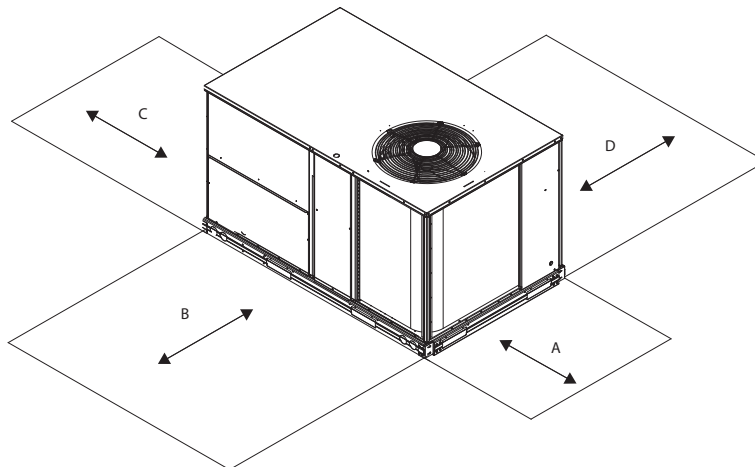

Service Clearance

LOC	DIMENSION	CONDITION
A	48-in (1219 mm)	Unit disconnect is mounted on panel
	18-in (457 mm)	No disconnect, convenience outlet option
	18-in (457 mm)	Recommended service clearance
	12-in (305 mm)	Minimum clearance
B	42-in (1067 mm)	Surface behind servicer is grounded (e.g., metal, masonry wall)
	36-in (914 mm)	Surface behind servicer is electrically non-conductive (e.g., wood, fiberglass)
C	36-in (914 mm)	Side condensate drain is used
	18-in (457 mm)	Minimum clearance
D	42-in (1067 mm)	Surface behind servicer is grounded (e.g., metal, masonry wall, another unit)
	36-in (914 mm)	Surface behind servicer is electrically non-conductive (e.g., wood, fiberglass)

Cooling Capacities

50TCM - A07 - 6 Tons - (50Hz-400V)

Temp (F) Air Entering Condenser (Edb)		Evaporator Air - CFM/BPF														
		1800 / 0.075			2100 / 0.106			2400 / 0.141			2700 / 0.178			2850 / 0.199		
		Evaporator Air - EWB (F)														
		62	67	72	62	67	72	62	67	72	62	67	72	62	67	72
75	TC	65,315	70,359	73,793	67,134	71,788	75,454	68,819	72,747	76,836	71,782	73,498	78,142	71,916	74,052	78,909
	SHC	58,487	47,717	36,989	63,121	50,441	38,421	66,140	52,620	39,871	65,883	54,410	41,473	68,598	55,883	42,563
	kW	3.33	3.37	3.40	3.35	3.39	3.42	3.36	3.40	3.44	3.37	3.40	3.45	3.38	3.41	3.46
85	TC	61,817	67,277	72,311	63,820	68,772	73,693	66,116	70,002	74,637	67,809	71,068	75,408	68,889	71,603	75,803
	SHC	56,990	47,131	36,918	61,675	50,476	38,679	64,022	53,520	40,019	66,268	56,663	41,226	67,324	58,364	41,825
	kW	3.80	3.84	3.89	3.81	3.85	3.90	3.83	3.87	3.91	3.84	3.88	3.93	3.86	3.88	3.93
95	TC	58,776	64,705	70,362	61,408	66,196	71,852	63,790	67,403	73,016	65,848	68,343	73,911	66,943	68,842	74,398
	SHC	54,964	45,864	36,061	58,797	49,480	38,043	61,094	52,886	39,828	63,065	56,163	41,564	64,114	58,063	42,678
	kW	4.30	4.35	4.40	4.32	4.36	4.41	4.34	4.37	4.43	4.35	4.38	4.44	4.37	4.39	4.45
105	TC	55,722	61,491	67,909	58,946	63,115	69,347	61,370	64,250	70,390	63,482	65,264	71,272	64,623	65,812	71,743
	SHC	50,537	42,849	33,779	53,461	46,611	35,884	55,660	50,015	37,773	57,575	53,472	39,659	58,609	55,429	40,827
	kW	4.71	4.79	4.85	4.77	4.81	4.86	4.79	4.82	4.88	4.81	4.83	4.89	4.82	4.83	4.89
115	TC	51,260	55,862	62,652	54,410	57,335	63,972	56,727	58,486	64,932	58,751	59,553	65,783	59,866	60,193	66,257
	SHC	46,490	40,831	32,174	49,347	44,568	34,348	51,449	48,061	36,316	53,284	51,426	38,364	54,295	53,391	39,651
	kW	5.25	5.36	5.41	5.34	5.37	5.43	5.36	5.38	5.44	5.38	5.39	5.45	5.39	5.39	5.46
120	TC	48,914	52,834	59,735	51,985	54,297	61,018	54,292	55,434	61,990	56,216	56,547	62,756	56,979	57,290	63,193
	SHC	44,362	39,757	31,257	47,148	43,513	33,481	49,240	46,964	35,515	50,985	50,258	37,546	51,983	51,959	38,871
	kW	5.54	5.64	5.70	5.63	5.66	5.72	5.65	5.66	5.73	5.67	5.67	5.74	5.68	5.68	5.75
125	TC	45,725	48,758	55,643	48,612	50,202	56,896	50,795	51,351	57,751	52,354	52,663	58,481	53,394	53,685	58,874
	SHC	41,385	37,842	29,681	43,998	41,561	31,910	45,974	44,858	33,915	47,666	47,665	35,954	48,590	48,559	37,220
	kW	5.89	5.97	6.06	5.98	6.01	6.07	6.01	6.02	6.09	6.03	6.03	6.10	6.04	6.04	6.10

50TCM - A07 - 6 Tons - (50Hz-400V)

Temp (C) Air Entering Condenser (Edb)		Evaporator Air - (L/s)/BPF														
		850 / 0.075			991 / 0.106			1133 / 0.141			1274 / 0.178			1345 / 0.199		
		Evaporator Air - EWB (C)														
		17	19	22	17	19	22	17	19	22	17	19	22	17	19	22
24	TC	19.1	20.6	21.6	19.7	21.0	22.1	20.2	21.3	22.5	21.0	21.5	22.9	21.1	21.7	23.1
	SHC	17.1	14.0	10.8	18.5	14.8	11.3	19.4	15.4	11.7	19.3	15.9	12.2	20.1	16.4	12.5
	kW	3.33	3.37	3.40	3.35	3.39	3.42	3.36	3.40	3.44	3.37	3.40	3.45	3.38	3.41	3.46
29	TC	18.1	19.7	21.2	18.7	20.2	21.6	19.4	20.5	21.9	19.9	20.8	22.1	20.2	21.0	22.2
	SHC	16.7	13.8	10.8	18.1	14.8	11.3	18.8	15.7	11.7	19.4	16.6	12.1	19.7	17.1	12.3
	kW	3.80	3.84	3.89	3.81	3.85	3.90	3.83	3.87	3.91	3.84	3.88	3.93	3.86	3.88	3.93
35	TC	17.2	19.0	20.6	18.0	19.4	21.1	18.7	19.8	21.4	19.3	20.0	21.7	19.6	20.2	21.8
	SHC	16.1	13.4	10.6	17.2	14.5	11.1	17.9	15.5	11.7	18.5	16.5	12.2	18.8	17.0	12.5
	kW	4.30	4.35	4.40	4.32	4.36	4.41	4.34	4.37	4.43	4.35	4.38	4.44	4.37	4.39	4.45
40.6	TC	16.3	18.0	19.9	17.3	18.5	20.3	18.0	18.8	20.6	18.6	19.1	20.9	18.9	19.3	21.0
	SHC	14.8	12.6	9.9	15.7	13.7	10.5	16.3	14.7	11.1	16.9	15.7	11.6	17.2	16.2	12.0
	kW	4.71	4.79	4.85	4.77	4.81	4.86	4.79	4.82	4.88	4.81	4.83	4.89	4.82	4.83	4.89
46	TC	15.0	16.4	18.4	15.9	16.8	18.7	16.6	17.1	19.0	17.2	17.5	19.3	17.5	17.6	19.4
	SHC	13.6	12.0	9.4	14.5	13.1	10.1	15.1	14.1	10.6	15.6	15.1	11.2	15.9	15.6	11.6
	kW	5.25	5.36	5.41	5.34	5.37	5.43	5.36	5.38	5.44	5.38	5.39	5.45	5.39	5.39	5.46
49	TC	14.3	15.5	17.5	15.2	15.9	17.9	15.9	16.2	18.2	16.5	16.6	18.4	16.7	16.8	18.5
	SHC	13.0	11.7	9.2	13.8	12.8	9.8	14.4	13.8	10.4	14.9	14.7	11.0	15.2	15.2	11.4
	kW	5.54	5.64	5.70	5.63	5.66	5.72	5.65	5.66	5.73	5.67	5.67	5.74	5.68	5.68	5.75
52	TC	13.4	14.3	16.3	14.2	14.7	16.7	14.9	15.1	16.9	15.3	15.4	17.1	15.6	15.7	17.3
	SHC	12.1	11.1	8.7	12.9	12.2	9.4	13.5	13.1	9.9	14.0	14.0	10.5	14.2	14.2	10.9
	kW	5.89	5.97	6.06	5.98	6.01	6.07	6.01	6.02	6.09	6.03	6.03	6.10	6.04	6.04	6.10

LEGEND

BPF — Bypass Factor
 Edb — Entering Dry-Bulb
 Ewb — Entering Wet-Bulb
 SHC — Sensible Heat Capacity (1000 Btuh) Gross
Bold, Italics - Standard Ratings
 Ldb — Leaving Dry-Bulb
 Lwb — Leaving Wet-Bulb
 TC — Total Capacity (1000 Btuh) Gross
 kW — Compressor Motor Power Input

Notes:

- Direct interpolation is permissible. Do not extrapolate.
- The following formulas may be used.

$$t_{ldb} = t_{edb} - \frac{\text{sensible capacity (Btuh)}}{1.10 \times \text{cfm}}$$

$$t_{lwb} = \text{Wet-bulb temperature corresponding to enthalpy of air leaving evaporator coil (hlwb)}$$

$$h_{lwb} = h_{ewb} - \frac{\text{total capacity (Btuh)}}{4.5 \times \text{cfm}}$$

Where: hewb = Enthalpy of air entering evaporator coil.

- Cooling capacities are gross and do not include deductions for indoor fan motor heat.
- Variable Air Volume units will operate down to 70 cfm/ton. Performance at 70 cfm/ton is limited to unloaded operation and may be additionally limited to edb and ewb conditions.

- The SHC is based on 80 F edb temperature of air entering evaporator coil.
 - Below 80 F edb, subtract (corr factor x cfm) from SHC.
 - Above 80 F edb, add (corr factor x cfm) to SHC.

BF	ENTERING AIR DRY-BULB TEMP (F)					
	79	78	77	76	75	under 75
	81	82	83	84	85	over 85
Correction Factor						
0.05	1.04	2.07	3.11	4.14	5.18	Use formula shown below.*
0.10	0.98	1.96	2.94	3.92	4.90	
0.20	0.87	1.74	2.62	3.49	4.36	
0.30	0.76	1.53	2.29	3.05	3.82	

- Interpolation is permissible.

*Correction Factor = 1.10 x (1 - BF) x (edb - 80).

Cooling Capacities (Continued)

50TCM - D08 - 7.5 Tons - (50Hz-400V)

Temp (F) Air Entering Condenser (Edb)		Evaporator Air - CFM/BPF														
		2250 / 0.098			2625 / 0.126			3000 / 0.152			3375 / 0.185			3750 / 0.206		
		Evaporator Air - EWB (F)														
		62	67	72	62	67	72	62	67	72	62	67	72	62	67	72
75	TC	81,619	89,460	94,879	84,072	91,530	96,303	86,130	92,684	97,296	88,726	93,764	98,356	90,143	94,347	98,992
	SHC	71,447	59,941	47,295	77,096	64,030	49,218	81,453	67,164	50,793	85,960	70,782	52,713	82,770	72,983	53,947
	kW	3.71	3.68	3.70	3.70	3.68	3.71	3.69	3.69	3.71	3.68	3.69	3.72	3.69	3.69	3.73
85	TC	77,878	85,762	93,313	80,370	88,070	94,815	82,603	89,571	95,786	85,647	91,020	96,864	87,668	91,757	97,416
	SHC	68,299	57,296	46,005	73,806	61,697	48,237	77,583	65,229	49,939	81,065	69,559	52,061	81,980	72,286	53,357
	kW	4.32	4.32	4.32	4.33	4.31	4.33	4.32	4.31	4.33	4.31	4.33	4.34	4.31	4.32	4.35
95	TC	76,001	83,898	92,511	78,830	86,201	94,570	81,413	87,759	95,848	84,451	89,332	97,008	86,235	90,173	97,580
	SHC	71,632	59,987	48,299	77,145	64,788	51,124	80,400	68,747	53,370	83,609	73,806	56,049	85,375	76,817	57,663
	kW	4.98	5.04	5.04	5.01	5.04	5.05	5.04	5.03	5.06	5.04	5.03	5.06	5.03	5.04	5.07
105	TC	68,531	75,876	84,250	71,740	77,891	86,314	74,335	79,267	87,622	77,176	80,730	88,917	78,790	81,541	89,576
	SHC	64,429	54,034	43,299	68,709	58,501	46,077	71,202	62,277	48,325	73,924	66,931	51,090	75,469	69,680	52,802
	kW	5.41	5.52	5.55	5.46	5.54	5.56	5.50	5.54	5.57	5.54	5.55	5.57	5.54	5.55	5.58
115	TC	61,443	67,841	76,021	64,860	69,670	77,942	67,390	70,919	79,212	70,035	72,318	80,494	71,512	73,063	81,131
	SHC	59,843	50,985	40,640	63,171	55,488	43,407	65,636	59,149	45,681	68,212	63,596	48,543	69,650	66,309	50,332
	kW	6.23	6.35	6.49	6.30	6.40	6.50	6.35	6.43	6.50	6.41	6.46	6.51	6.45	6.48	6.51
120	TC	58,337	64,976	73,166	62,463	66,688	74,996	64,897	68,018	76,234	67,543	69,331	77,502	68,987	70,094	78,166
	SHC	56,508	49,299	39,248	59,724	53,704	41,973	62,070	57,319	44,220	64,595	61,674	47,038	66,006	64,281	48,838
	kW	6.76	6.76	6.94	6.84	6.81	6.95	6.90	6.84	6.96	6.96	6.88	6.97	7.00	6.90	6.97
125	TC	54,838	59,572	67,854	58,035	61,280	69,572	60,333	62,517	70,724	62,881	63,834	71,911	64,304	64,726	72,522
	SHC	54,291	47,806	37,962	57,456	52,164	40,723	59,731	55,749	42,988	62,253	60,060	45,852	63,662	62,534	47,636
	kW	7.14	7.26	7.49	7.22	7.31	7.53	7.29	7.35	7.55	7.36	7.39	7.56	7.40	7.41	7.56

50TCM - D08 - 7.5 Tons - (50Hz-400V)

Temp (C) Air Entering Condenser (Edb)		Evaporator Air - (L/s)/BPF														
		1062 / 0.098			1239 / 0.126			1416 / 0.152			1593 / 0.185			1770 / 0.206		
		Evaporator Air - EWB (C)														
		17	19	22	17	19	22	17	19	22	17	19	22	17	19	22
24	TC	23.9	26.2	27.8	24.6	26.8	28.2	25.2	27.2	28.5	26.0	27.5	28.8	26.4	27.7	29.0
	SHC	20.9	17.6	13.9	22.6	18.8	14.4	23.9	19.7	14.9	25.2	20.7	15.4	24.3	21.4	15.8
	kW	3.71	3.68	3.70	3.70	3.68	3.71	3.69	3.69	3.71	3.68	3.69	3.72	3.69	3.69	3.73
29	TC	22.8	25.1	27.3	23.6	25.8	27.8	24.2	26.3	28.1	25.1	26.7	28.4	25.7	26.9	28.6
	SHC	20.0	16.8	13.5	21.6	18.1	14.1	22.7	19.1	14.6	23.8	20.4	15.3	24.0	21.2	15.6
	kW	4.32	4.32	4.32	4.33	4.31	4.33	4.32	4.31	4.33	4.31	4.31	4.34	4.31	4.32	4.35
35	TC	22.3	24.6	27.1	23.1	25.3	27.7	23.9	25.7	28.1	24.8	26.2	28.4	25.3	26.4	28.6
	SHC	21.0	17.6	14.2	22.6	19.0	15.0	23.6	20.1	15.6	24.5	21.6	16.4	25.0	22.5	16.9
	kW	4.98	5.04	5.04	5.01	5.04	5.05	5.04	5.03	5.06	5.04	5.03	5.06	5.03	5.04	5.07
40.6	TC	20.1	22.2	24.7	21.0	22.8	25.3	21.8	23.2	25.7	22.6	23.7	26.1	23.1	23.9	26.3
	SHC	18.9	15.8	12.7	20.1	17.1	13.5	20.9	18.3	14.2	21.7	19.6	15.0	22.1	20.4	15.5
	kW	5.41	5.52	5.55	5.46	5.54	5.56	5.50	5.54	5.57	5.54	5.55	5.57	5.54	5.55	5.58
46	TC	18.0	19.9	22.3	19.0	20.4	22.8	19.8	20.8	23.2	20.5	21.2	23.6	21.0	21.4	23.8
	SHC	17.5	14.9	11.9	18.5	16.3	12.7	19.2	17.3	13.4	20.0	18.6	14.2	20.4	19.4	14.8
	kW	6.23	6.35	6.49	6.30	6.40	6.50	6.35	6.43	6.50	6.41	6.46	6.51	6.45	6.48	6.51
49	TC	17.1	19.0	21.4	18.3	19.5	22.0	19.0	19.9	22.3	19.8	20.3	22.7	20.2	20.5	22.9
	SHC	16.6	14.4	11.5	17.5	15.7	12.3	18.2	16.8	13.0	18.9	18.1	13.8	19.3	18.8	14.3
	kW	6.76	6.76	6.94	6.84	6.81	6.95	6.90	6.84	6.96	6.96	6.88	6.97	7.00	6.90	6.97
52	TC	16.1	17.5	19.9	17.0	18.0	20.4	17.7	18.3	20.7	18.4	18.7	21.1	18.8	19.0	21.3
	SHC	15.9	14.0	11.1	16.8	15.3	11.9	17.5	16.3	12.6	18.2	17.6	13.4	18.7	18.3	14.0
	kW	7.14	7.26	7.49	7.22	7.31	7.53	7.29	7.35	7.55	7.36	7.39	7.56	7.40	7.41	7.56

LEGEND

- BPF — Bypass Factor
- Edb — Entering Dry-Bulb
- Ewb — Entering Wet-Bulb
- SHC — Sensible Heat Capacity (1000 Btuh) Gross
- TC — Total Capacity (1000 Btuh) Gross
- kW — Compressor Motor Power Input
- Ldb — Leaving Dry-Bulb
- Lwb — Leaving Wet-Bulb

Bold, Italics - Standard Ratings

Notes:

1. Direct interpolation is permissible. Do not extrapolate.
2. The following formulas may be used.

$$t_{ldb} = t_{edb} - \frac{\text{sensible capacity (Btuh)}}{1.10 \times \text{cfm}}$$

t_{lwb} = Wet-bulb temperature corresponding to enthalpy of air leaving evaporator coil (hlwb).

$$hlwb = h_{ewb} - \frac{\text{total capacity (Btuh)}}{4.5 \times \text{cfm}}$$

Where: h_{ewb} = Enthalpy of air entering evaporator coil.

4. Cooling capacities are gross and do not include deductions for indoor fan motor heat.
5. Variable Air Volume units will operate down to 70 cfm/ton. Performance at 70 cfm/ton is limited to unloaded operation and may be additionally limited to edb and ewb conditions.

3. The SHC is based on 80 F edb temperature of air entering evaporator coil.
 - Below 80 F edb, subtract (corr factor x cfm) from SHC.
 - Above 80 F edb, add (corr factor x cfm) to SHC.

BF	ENTERING AIR DRY-BULB TEMP (F)					
	79	78	77	76	75	under 75
	81	82	83	84	85	over 85
Correction Factor						
0.05	1.04	2.07	3.11	4.14	5.18	Use formula shown below.*
0.10	0.98	1.96	2.94	3.92	4.90	
0.20	0.87	1.74	2.62	3.49	4.36	
0.30	0.76	1.53	2.29	3.05	3.82	

- Interpolation is permissible.
*Correction Factor = 1.10 x (1 - BF) x (edb - 80).

Cooling Capacities (Continued)

50TCM - D09 - 8.5 Tons - (50Hz-400V)

Temp (F) Air Entering Condenser (Edb)		Evaporator Air - CFM/BPF														
		2550 / 0.077			2975 / 0.111			3400 / 0.140			3650 / 0.169			4250 / 0.193		
		Evaporator Air - EWB (F)														
		62	67	72	62	67	72	62	67	72	62	67	72	62	67	72
75	TC	92900	103012	113748	97061	106382	117021	100460	108675	119597	103566	110549	121599	105317	111929	123257
	SHC	82097	70292	57340	88629	76124	60982	94625	81695	64514	99774	86886	67824	100170	91744	71112
	kW	4.3	4.4	4.5	4.3	4.4	4.5	4.3	4.4	4.6	4.4	4.5	4.6	4.5	4.5	4.6
85	TC	88016	97392	108220	92158	100347	111658	95422	102604	114051	98512	104356	115889	101462	106018	117422
	SHC	79102	68031	55318	85087	73841	59083	90915	79343	62599	95609	84446	65906	98472	89530	69179
	kW	4.8	5.0	5.1	4.9	5.0	5.1	4.9	5.0	5.2	5.0	5.0	5.2	5.0	5.1	5.2
95	TC	82309	91501	101860	86172	94058	104805	89922	96143	107130	93366	97723	108899	96172	99286	110392
	SHC	75311	65661	53021	81493	71358	56679	87273	76803	60227	90615	81784	63558	93339	86278	66860
	kW	5.5	5.6	5.7	5.5	5.6	5.8	5.6	5.7	5.8	5.6	5.7	5.8	5.7	5.7	5.9
105	TC	76325	84073	95162	80167	86727	97825	84073	88801	99838	87283	90830	101428	90171	92858	102733
	SHC	71249	62758	50630	77806	68466	54255	81596	73864	57760	84712	78388	61068	87515	82192	64346
	kW	6.3	6.4	6.6	6.3	6.4	6.6	6.4	6.5	6.7	6.4	6.5	6.7	6.5	6.5	6.7
115	TC	70101	76483	87365	74284	78757	90033	77874	80933	92236	80862	83114	93632	83498	84963	94754
	SHC	66703	58854	47159	71014	64301	50805	74446	68886	54374	77302	72604	57607	79822	76203	60816
	kW	7.1	7.2	7.4	7.2	7.2	7.4	7.2	7.3	7.5	7.3	7.3	7.5	7.3	7.3	7.5
120	TC	70247	75958	87114	74373	78164	89715	77957	80786	91788	80965	82912	93478	83616	84682	94663
	SHC	65199	57780	46202	69028	62940	49820	72355	67296	53345	75146	70952	56678	77607	74606	59909
	kW	7.5	7.6	7.8	7.6	7.6	7.8	7.6	7.7	7.9	7.7	7.7	7.9	7.7	7.7	8.0
125	TC	66351	70597	81646	70289	73083	84072	73650	75688	85874	76514	77735	87221	78999	79535	88350
	SHC	61463	55692	44336	65111	60029	47940	68225	64169	51414	70878	67809	54649	73180	71503	57870
	kW	8.1	8.2	8.4	8.2	8.2	8.4	8.2	8.3	8.4	8.3	8.3	8.5	8.3	8.3	8.5

50TCM - D09 - 8.5 Tons - (50Hz-400V)

Temp (C) Air Entering Condenser (Edb)		Evaporator Air - (L/s)/BPF														
		1203 / 0.077			1404 / 0.111			1605 / 0.140			1723 / 0.169			2006 / 0.193		
		Evaporator Air - EWB (C)														
		17	19	22	17	19	22	17	19	22	17	19	22	17	19	22
24	TC	27.2	30.2	33.3	28.4	31.2	34.3	29.4	31.9	35.1	30.4	32.4	35.6	30.9	32.8	36.1
	SHC	24.1	20.6	16.8	26.0	22.3	17.9	27.7	23.9	18.9	29.2	25.5	19.9	29.4	26.9	20.8
	kW	4.3	4.4	4.5	4.3	4.4	4.5	4.3	4.4	4.6	4.4	4.5	4.6	4.5	4.5	4.6
29	TC	25.8	28.5	31.7	27.0	29.4	32.7	28.0	30.1	33.4	28.9	30.6	34.0	29.7	31.1	34.4
	SHC	23.2	19.9	16.2	24.9	21.6	17.3	26.6	23.3	18.3	28.0	24.7	19.3	28.9	26.2	20.3
	kW	4.8	5.0	5.1	4.9	5.0	5.1	4.9	5.0	5.2	5.0	5.0	5.2	5.0	5.1	5.2
35	TC	24.1	26.8	29.9	25.3	27.6	30.7	26.4	28.2	31.4	27.4	28.6	31.9	28.2	29.1	32.4
	SHC	22.1	19.2	15.5	23.9	20.9	16.6	25.6	22.5	17.7	26.6	24.0	18.6	27.4	25.3	19.6
	kW	5.5	5.6	5.7	5.5	5.6	5.8	5.6	5.7	5.8	5.6	5.7	5.8	5.7	5.7	5.9
40.6	TC	22.4	24.6	27.9	23.5	25.4	28.7	24.6	26.0	29.3	25.6	26.6	29.7	26.4	27.2	30.1
	SHC	20.9	18.4	14.8	22.8	20.1	15.9	23.9	21.6	16.9	24.8	23.0	17.9	25.6	24.1	18.9
	kW	6.3	6.4	6.6	6.3	6.4	6.6	6.4	6.5	6.7	6.4	6.5	6.7	6.5	6.5	6.7
46	TC	20.5	22.4	25.6	21.8	23.1	26.4	22.8	23.7	27.0	23.7	24.4	27.4	24.5	24.9	27.8
	SHC	19.5	17.2	13.8	20.8	18.8	14.9	21.8	20.2	15.9	22.7	21.3	16.9	23.4	22.3	17.8
	kW	7.1	7.2	7.4	7.2	7.2	7.4	7.2	7.3	7.5	7.3	7.3	7.5	7.3	7.3	7.5
49	TC	20.6	22.3	25.5	21.8	22.9	26.3	22.8	23.7	26.9	23.7	24.3	27.4	24.5	24.8	27.7
	SHC	19.1	16.9	13.5	20.2	18.4	14.6	21.2	19.7	15.6	22.0	20.8	16.6	22.7	21.9	17.6
	kW	7.5	7.6	7.8	7.6	7.6	7.8	7.6	7.7	7.9	7.7	7.7	7.9	7.7	7.7	8.0
52	TC	19.4	20.7	23.9	20.6	21.4	24.6	21.6	22.2	25.2	22.4	22.8	25.6	23.2	23.3	25.9
	SHC	18.0	16.3	13.0	19.1	17.6	14.1	20.0	18.8	15.1	20.8	19.9	16.0	21.4	21.0	17.0
	kW	8.1	8.2	8.4	8.2	8.2	8.4	8.2	8.3	8.4	8.3	8.3	8.5	8.3	8.3	8.5

LEGEND

- BPF — Bypass Factor
- Edb — Entering Dry-Bulb
- Ewb — Entering Wet-Bulb
- SHC — Sensible Heat Capacity (1000 Btuh) Gross
- TC — Total Capacity (1000 Btuh) Gross
- kW — Compressor Motor Power Input
- Ldb — Leaving Dry-Bulb
- Lwb — Leaving Wet-Bulb

Bold, Italics - Standard Ratings

Notes:

1. Direct interpolation is permissible. Do not extrapolate.
2. The following formulas may be used.

$$t_{ldb} = t_{edb} - \frac{\text{sensible capacity (Btuh)}}{1.10 \times \text{cfm}}$$

$$t_{lwb} = \text{Wet-bulb temperature corresponding to enthalpy of air leaving evaporator coil (hlwb)}$$

$$h_{lwb} = h_{ewb} - \frac{\text{total capacity (Btuh)}}{4.5 \times \text{cfm}}$$

Where: hewb = Enthalpy of air entering evaporator coil.

4. Cooling capacities are gross and do not include deductions for indoor fan motor heat.
5. Variable Air Volume units will operate down to 70 cfm/ton. Performance at 70 cfm/ton is limited to unloaded operation and may be additionally limited to edb and ewb conditions.

3. The SHC is based on 80 F edb temperature of air entering evaporator coil.
 - Below 80 F edb, subtract (corr factor x cfm) from SHC.
 - Above 80 F edb, add (corr factor x cfm) to SHC.

BF	ENTERING AIR DRY-BULB TEMP (F)					
	79	78	77	76	75	under 75
	81	82	83	84	85	over 85
Correction Factor						
0.05	1.04	2.07	3.11	4.14	5.18	Use formula shown below.*
0.10	0.98	1.96	2.94	3.92	4.90	
0.20	0.87	1.74	2.62	3.49	4.36	
0.30	0.76	1.53	2.29	3.05	3.82	

- Interpolation is permissible.
- *Correction Factor = 1.10 x (1 - BF) x (edb - 80).

Cooling Capacities (Continued)

50TCM - D12 - 10 Tons - (50Hz-400V)

Temp (F) Air Entering Condenser (Edb)		Evaporator Air - CFM/BPF														
		3000 / 0.061			3500 / 0.087			4000 / 0.117			4250 / 0.134			4500 / 0.146		
		Evaporator Air - EWB (F)														
		62	67	72	62	67	72	62	67	72	62	67	72	62	67	72
75	TC	111,658	120,524	127,074	114,738	122,856	129,653	118,251	124,616	132,229	119,811	125,261	133,220	120,255	126,103	134,406
	SHC	98,488	81,344	63,473	106,112	86,596	66,407	112,071	91,490	69,643	113,772	93,670	71,164	110,208	96,221	72,881
	kW	5.08	5.14	5.23	5.09	5.17	5.27	5.11	5.20	5.31	5.12	5.21	5.32	5.17	5.22	5.35
85	TC	106,837	116,600	125,240	110,440	119,570	127,366	113,887	121,718	129,133	115,718	122,417	129,828	117,476	123,189	130,830
	SHC	96,772	80,697	63,486	104,081	87,230	66,653	109,665	93,315	69,687	111,432	96,047	71,111	113,148	98,788	72,830
	kW	5.91	5.95	6.06	5.92	5.98	6.09	5.94	6.00	6.12	5.95	6.01	6.13	5.97	6.03	6.15
95	TC	100,916	110,649	121,382	105,091	113,452	123,991	109,048	115,544	125,768	110,784	116,413	126,382	112,481	117,249	127,085
	SHC	93,140	78,613	62,771	100,590	85,258	66,606	105,030	91,587	70,119	106,702	94,596	71,697	108,336	97,563	73,354
	kW	6.77	6.87	6.94	6.84	6.89	6.98	6.86	6.90	7.02	6.86	6.91	7.02	6.88	6.92	7.04
105	TC	91,264	100,479	111,135	95,953	103,099	113,754	100,100	105,084	115,759	101,882	105,848	116,529	103,453	106,624	117,246
	SHC	87,936	75,201	59,837	94,323	81,873	63,919	98,400	88,230	67,830	100,151	91,198	69,698	101,696	94,254	71,564
	kW	7.51	7.68	7.77	7.61	7.71	7.80	7.68	7.73	7.82	7.70	7.73	7.83	7.72	7.74	7.84
115	TC	82,379	90,057	101,320	87,293	92,680	103,734	91,298	94,544	105,526	93,040	95,470	106,278	94,538	96,256	106,948
	SHC	80,847	70,320	55,885	85,670	76,915	59,932	89,600	83,126	63,838	91,310	86,064	65,741	92,780	88,524	67,633
	kW	8.02	8.20	8.39	8.14	8.26	8.41	8.23	8.29	8.43	8.25	8.30	8.43	8.29	8.31	8.45
120	TC	78,301	85,140	96,356	83,044	87,657	98,747	86,973	89,552	100,461	88,652	90,496	101,190	90,118	91,415	101,823
	SHC	75,173	66,177	52,552	79,726	72,518	56,475	83,498	78,432	60,223	85,110	80,996	62,051	86,518	83,058	63,898
	kW	8.56	8.73	8.97	8.68	8.81	9.01	8.79	8.85	9.03	8.82	8.85	9.03	8.85	8.87	9.05
125	TC	72,828	77,966	89,419	77,314	80,362	91,670	81,077	82,700	93,417	82,794	83,861	94,223	84,171	84,823	94,759
	SHC	69,916	63,094	49,987	74,223	69,333	53,898	77,835	74,332	57,683	79,484	76,731	59,571	80,806	78,872	61,350
	kW	9.17	9.32	9.61	9.30	9.40	9.66	9.42	9.46	9.70	9.47	9.48	9.72	9.50	9.51	9.73

50TCM - D12 - 10 Tons - (50Hz-400V)

Temp (C) Air Entering Condenser (Edb)		Evaporator Air - (L/s)/BPF														
		1416 / 0.061			1652 / 0.087			1888 / 0.117			2006 / 0.134			2124 / 0.146		
		Evaporator Air - EWB (C)														
		17	19	22	17	19	22	17	19	22	17	19	22	17	19	22
24	TC	33.1	35.7	37.6	34.0	36.4	38.4	35.0	36.9	39.2	35.5	37.1	39.5	35.6	37.4	39.8
	SHC	29.2	24.1	18.8	31.4	25.7	19.7	33.2	27.1	20.6	33.7	27.7	21.1	32.6	28.5	21.6
	kW	5.08	5.14	5.23	5.09	5.17	5.27	5.11	5.20	5.31	5.12	5.21	5.32	5.17	5.22	5.35
29	TC	31.7	34.5	37.1	32.7	35.4	37.7	33.7	36.1	38.3	34.3	36.3	38.5	34.8	36.5	38.8
	SHC	28.7	23.9	18.8	30.8	25.8	19.7	32.5	27.6	20.6	33.0	28.5	21.1	33.5	29.3	21.6
	kW	5.91	5.95	6.06	5.92	5.98	6.09	5.94	6.00	6.12	5.95	6.01	6.13	5.97	6.03	6.15
35	TC	29.9	32.8	36.0	31.1	33.6	36.7	32.3	34.2	37.3	32.8	34.5	37.4	33.3	34.7	37.6
	SHC	27.6	23.3	18.6	29.8	25.3	19.7	31.1	27.1	20.8	31.6	28.0	21.2	32.1	28.9	21.7
	kW	6.77	6.87	6.94	6.84	6.89	6.98	6.86	6.90	7.02	6.86	6.91	7.02	6.88	6.92	7.04
40.6	TC	27.0	29.8	32.9	28.4	30.5	33.7	29.7	31.1	34.3	30.2	31.4	34.5	30.6	31.6	34.7
	SHC	26.1	22.3	17.7	27.9	24.3	18.9	29.2	26.1	20.1	29.7	27.0	20.6	30.1	27.9	21.2
	kW	7.51	7.68	7.77	7.61	7.71	7.80	7.68	7.73	7.82	7.70	7.73	7.83	7.72	7.74	7.84
46	TC	24.4	26.7	30.0	25.9	27.5	30.7	27.0	28.0	31.3	27.6	28.3	31.5	28.0	28.5	31.7
	SHC	24.0	20.8	16.6	25.4	22.8	17.8	26.5	24.6	18.9	27.1	25.5	19.5	27.5	26.2	20.0
	kW	8.02	8.20	8.39	8.14	8.26	8.41	8.23	8.29	8.43	8.25	8.30	8.43	8.29	8.31	8.45
49	TC	23.2	25.2	28.5	24.6	26.0	29.3	25.8	26.5	29.8	26.3	26.8	30.0	26.7	27.1	30.2
	SHC	22.3	19.6	15.6	23.6	21.5	16.7	24.7	23.2	17.8	25.2	24.0	18.4	25.6	24.6	18.9
	kW	8.56	8.73	8.97	8.68	8.81	9.01	8.79	8.85	9.03	8.82	8.85	9.03	8.85	8.87	9.05
52	TC	21.6	23.1	26.5	22.9	23.8	27.2	24.0	24.5	27.7	24.5	24.8	27.9	24.9	25.1	28.1
	SHC	20.7	18.7	14.8	22.0	20.5	16.0	23.1	22.0	17.1	23.5	22.7	17.6	23.9	23.4	18.2
	kW	9.17	9.32	9.61	9.30	9.40	9.66	9.42	9.46	9.70	9.47	9.48	9.72	9.50	9.51	9.73

LEGEND

- BPF — Bypass Factor
- Edb — Entering Dry-Bulb
- Ewb — Entering Wet-Bulb
- SHC — Sensible Heat Capacity (1000 Btuh) Gross
- Bold, Italics** - Standard Ratings
- Notes:
- 1. Direct interpolation is permissible. Do not extrapolate.
- 2. The following formulas may be used.

$$t_{ldb} = t_{edb} - \frac{\text{sensible capacity (Btuh)}}{1.10 \times \text{cfm}}$$

$$t_{wb} = \text{Wet-bulb temperature corresponding to enthalpy of air leaving evaporator coil (hlwb)}$$

$$hlwb = h_{ewb} - \frac{\text{total capacity (Btuh)}}{4.5 \times \text{cfm}}$$

Where: hewb = Enthalpy of air entering evaporator coil.

- 4. Cooling capacities are gross and do not include deductions for indoor fan motor heat.
- 5. Variable Air Volume units will operate down to 70 cfm/ton. Performance at 70 cfm/ton is limited to unloaded operation and may be additionally limited to edb and ewb conditions.

- 3. The SHC is based on 80 F edb temperature of air entering evaporator coil.
- Below 80 F edb, subtract (corr factor x cfm) from SHC.
- Above 80 F edb, add (corr factor x cfm) to SHC.

BF	ENTERING AIR DRY-BULB TEMP (F)					
	79	78	77	76	75	under 75
	81	82	83	84	85	over 85
Correction Factor						
0.05	1.04	2.07	3.11	4.14	5.18	Use formula shown below.*
0.10	0.98	1.96	2.94	3.92	4.90	
0.20	0.87	1.74	2.62	3.49	4.36	
0.30	0.76	1.53	2.29	3.05	3.82	

- Interpolation is permissible.
- *Correction Factor = 1.10 x (1 - BF) x (edb - 80).

Cooling Capacities (Continued)

50TCM - D13 - 11 Tons - (50Hz-400V)

Temp (F) Air Entering Condenser (Edb)		Evaporator Air - CFM/BPF														
		3000 / 0.018			3400 / 0.026			3800 / 0.034			4200 / 0.044			4600 / 0.056		
		Evaporator Air - EWB (F)														
		62	67	72	62	67	72	62	67	72	62	67	72	62	67	72
75	TC	123,860	127,467	133,847	124,036	128,224	134,198	124,088	128,151	133,918	123,837	127,525	133,263	123,225	126,458	132,049
	SHC	109,969	90,896	33,915	113,870	94,448	72,684	117,582	97,612	74,240	120,632	100,358	75,776	121,993	102,834	76,791
	kW	6.82	6.90	7.02	6.85	6.94	7.05	6.88	6.97	7.07	6.90	6.99	7.09	6.90	7.00	7.10
85	TC	124,732	133,336	141,772	126,539	134,471	142,822	127,976	134,768	143,499	129,043	134,434	143,454	129,990	133,743	142,843
	SHC	113,136	98,027	75,458	120,289	103,132	78,066	127,056	107,755	80,656	127,753	111,873	82,973	128,690	115,833	85,183
	kW	7.81	7.90	8.00	7.84	7.94	8.02	7.87	7.97	8.05	7.90	7.99	8.08	7.93	8.02	8.10
95	TC	120,646	130088	143,203	122,929	131880.5	144,517	124,516	132,812	145,034	126,439	133,218	144,936	128,119	133,019	144,338
	SHC	111,652	97179	76,826	119,516	103066	79,421	123,271	108787	83035.00	125,175	114,431	85,799	126,838	119,707	88,423
	kW	8.82	8.96	9.12	8.89	8.98	9.15	8.93	9.01	9.18	8.95	9.03	9.21	9.00	9.05	9.23
105	TC	108,582	117,079	128,883	110,636	118,692	130,065	112,064	119,530	130,530	113,795	119,896	130,442	115,307	119,717	129,904
	SHC	104,769	90,417	70,591	109,529	96,241	73,662	110,944	101,672	76,432	112,657	106,997	79,024	114,154	112,037	81,714
	kW	9.85	9.95	10.12	9.89	9.98	10.15	9.93	10.01	10.18	9.97	10.03	10.21	10.00	10.05	10.23
115	TC	98,475	107,515	120,719	101,743	108,750	121,797	104,256	109,340	121,963	105,729	109,445	121,456	106,920	109,148	120,545
	SHC	98,197	86,510	67,354	100,726	91,514	70,589	103,213	96,786	73,475	104,672	101,984	76,103	105,851	106,835	78,535
	kW	10.78	11.01	11.17	10.94	11.04	11.21	10.99	11.07	11.25	11.04	11.09	11.27	11.08	11.11	11.30
118.4	TC	95,909	104,611	118,037	99,193	105,860	119,165	101,924	106,442	119,452	103,724	106,613	119,103	104,433	106,347	118,148
	SHC	94,950	84,674	66,379	98,201	90,320	69,644	100,904	95,725	72,682	102,686	100,973	75,476	103,389	105,800	77,977
	kW	11.11	11.37	11.53	11.27	11.40	11.57	11.36	11.42	11.60	11.40	11.45	11.63	11.44	11.47	11.65
125	TC	90,657	98,741	112,500	94,491	99,982	113,566	97,041	100,537	113,864	98,564	100,705	113,555	99,551	100,894	112,725
	SHC	89,751	82,345	64,362	93,546	88,090	67,690	96,070	93,527	70,817	97,578	98,693	73,775	98,556	99,885	76,538
	kW	11.74	12.04	12.23	11.92	12.08	12.27	12.06	12.11	12.30	12.10	12.13	12.32	12.14	12.16	12.34

50TCM - D13 - 11 Tons - (50Hz-400V)

Temp (C) Air Entering Condenser (Edb)		Evaporator Air - (L/s)/BPF														
		1416 / 0.018			1605 / 0.026			1795 / 0.034			1980 / 0.044			2170 / 0.056		
		Evaporator Air - EWB ©														
		17	19	22	17	19	22	17	19	22	17	19	22	17	19	22
24	TC	36.3	37.4	39.2	36.4	37.6	39.3	36.4	37.6	39.2	36.3	37.4	39.1	36.1	37.1	38.7
	SHC	32.2	26.6	9.9	33.4	27.7	21.3	34.5	28.6	21.8	35.4	29.4	22.2	35.8	30.1	22.5
	kW	6.82	6.90	7.02	6.85	6.94	7.05	6.88	6.97	7.07	6.90	6.99	7.09	6.90	7.00	7.10
29	TC	36.6	39.1	41.5	37.1	39.4	41.9	37.5	39.5	42.1	37.8	39.4	42.0	38.1	39.2	41.9
	SHC	33.2	28.7	22.1	35.3	30.2	22.9	37.2	31.6	23.6	37.4	32.8	24.3	37.7	33.9	25.0
	kW	7.81	7.90	8.00	7.84	7.94	8.02	7.87	7.97	8.05	7.90	7.99	8.08	7.93	8.02	8.10
35	TC	35.4	38.1	42.0	36.0	38.7	42.4	36.5	38.9	42.5	37.1	39.0	42.5	37.5	39.0	42.3
	SHC	32.7	28.5	22.5	35.0	30.2	23.3	36.1	31.9	24.3	36.7	33.5	25.1	37.2	35.1	25.9
	kW	8.82	8.96	9.12	8.89	8.98	9.15	8.93	9.01	9.18	8.95	9.03	9.21	9.00	9.05	9.23
40.6	TC	31.8	34.3	37.8	32.4	34.8	38.1	32.8	35.0	38.3	33.4	35.1	38.2	33.8	35.1	38.1
	SHC	30.7	26.5	20.7	32.1	28.2	21.6	32.5	29.8	22.4	33.0	31.4	23.2	33.5	32.8	23.9
	kW	9.85	9.95	10.12	9.89	9.98	10.15	9.93	10.01	10.18	9.97	10.03	10.21	10.00	10.05	10.23
46	TC	28.9	31.5	35.4	29.8	31.9	35.7	30.6	32.0	35.7	31.0	32.1	35.6	31.3	32.0	35.3
	SHC	28.8	25.4	19.7	29.5	26.8	20.7	30.2	28.4	21.5	30.7	29.9	22.3	31.0	31.3	23.0
	kW	10.78	11.01	11.17	10.94	11.04	11.21	10.99	11.07	11.25	11.04	11.09	11.27	11.08	11.11	11.30
48	TC	28.1	30.7	34.6	29.1	31.0	34.9	29.9	31.2	35.0	30.4	31.2	34.9	30.6	31.2	34.6
	SHC	27.8	24.8	19.5	28.8	26.5	20.4	29.6	28.1	21.3	30.1	29.6	22.1	30.3	31.0	22.9
	kW	11.11	11.37	11.53	11.27	11.40	11.57	11.36	11.42	11.60	11.40	11.45	11.63	11.44	11.47	11.65
52	TC	26.6	28.9	33.0	27.7	29.3	33.3	28.4	29.5	33.4	28.9	29.5	33.3	29.2	29.6	33.0
	SHC	26.3	24.1	18.9	27.4	25.8	19.8	28.2	27.4	20.8	28.6	28.9	21.6	28.9	29.3	22.4
	kW	11.74	12.04	12.23	11.92	12.08	12.27	12.06	12.11	12.30	12.10	12.13	12.32	12.14	12.16	12.34

LEGEND

- BPF — Bypass Factor
- Edb — Entering Dry-Bulb
- Ewb — Entering Wet-Bulb
- SHC — Sensible Heat Capacity (1000 Btuh) Gross
- Bold, Italics** - Standard Ratings
- Ldb — Leaving Dry-Bulb
- Lwb — Leaving Wet-Bulb
- TC — Total Capacity (1000 Btuh) Gross
- kW — Compressor Motor Power Input

Notes:

1. Direct interpolation is permissible. Do not extrapolate.
2. The following formulas may be used.
3. The SHC is based on 80 F edb temperature of air entering evaporator coil.

$$t_{ldb} = t_{edb} - \frac{\text{sensible capacity (Btuh)}}{1.10 \times \text{cfm}}$$

t_{lwb} = Wet-bulb temperature corresponding to enthalpy of air leaving evaporater coil (h_{lwb}).

$$h_{lwb} = h_{ewb} - \frac{\text{total capacity (Btuh)}}{4.5 \times \text{cfm}}$$

Where: h_{ewb} = Enthalpy of air entering evaporator coil.

4. Cooling capacities are gross and do not include deductions for indoor fan motor heat.
5. Variable Air Volume units will operate down to 70 cfm/ton. Performance at 70 cfm/ton is limited to unloaded operation and may be additionally limited to edb and ewb conditions.

BF	ENTERING AIR DRY-BULB TEMP (F)					
	79	78	77	76	75	under 75
	81	82	83	84	85	over 85
	Correction Factor					
0.05	1.04	2.07	3.11	4.14	5.18	Use
0.10	0.98	1.96	2.94	3.92	4.90	formula
0.20	0.87	1.74	2.62	3.49	4.36	shown
0.30	0.76	1.53	2.29	3.05	3.82	below.*

- Interpolation is permissible.
*Correction Factor = 1.10 x (1 - BF) x (edb - 80).

Fan Performance Table

Unit 50TCM - A07 - 6 Tons - 400V - 50Hz

Air Flow Rate (CFM)	Available External Static Pressure (in. wg)														
	0.2			0.4			0.6			0.8			1.0		
	RPM	KWI	BHP	RPM	KWI	BHP	RPM	KWI	BHP	RPM	KWI	BHP	RPM	KWI	BHP
1800	785	0.48	0.51	885	0.62	0.66	972	0.76	0.82	1051	0.91	0.98	1121	1.07	1.15
1950	833	0.58	0.62	929	0.74	0.79	1013	0.89	0.95	1089	1.05	1.13	1158	1.21	1.31
2100	881	0.70	0.75	973	0.86	0.92	1054	1.03	1.10	1129	1.20	1.29	1197	1.36	1.48
2250	930	0.84	0.90	1019	1.01	1.08	1097	1.18	1.27	1169	1.34	1.46	1236	1.53	1.66
2400	980	0.99	1.06	1065	1.17	1.26	1141	1.36	1.46	1211	1.53	1.66	1276	1.72	1.87
2550	1030	1.17	1.25	1112	1.36	1.46	1185	1.54	1.67	1253	1.73	1.88	1317	1.93	2.10
2700	1081	1.34	1.46	1159	1.54	1.67	1231	1.75	1.90	1297	1.95	2.12	1358	2.16	2.35
2850	1133	1.56	1.69	1207	1.77	1.92	1276	1.98	2.15						

Unit 50TCM - A07 - 6 Tons - 400V - 50Hz (Continued)

Air Flow Rate (CFM)	Available External Static Pressure (in. wg)														
	1.2			1.4			1.6			1.8			2.0		
	RPM	KWI	BHP	RPM	KWI	BHP	RPM	KWI	BHP	RPM	KWI	BHP	RPM	KWI	BHP
1800	1188	1.22	1.33	1249	1.39	1.51	1307	1.57	1.70	1363	1.75	1.90	1373	1.93	2.10
1950	1223	1.37	1.49	1284	1.55	1.68	1342	1.73	1.88	1396	1.92	2.09			
2100	1261	1.54	1.67	1320	1.72	1.87	1376	1.92	2.08	1431	2.11	2.29			
2250	1298	1.72	1.87	1356	1.92	2.08	1412	2.11	2.29						
2400	1337	1.92	2.09	1394	2.13	2.31									
2550	1376	2.15	2.33												
2700															
2850															

Unit 50TCM - D08 - 7.5 Tons - 400V - 50Hz

Air Flow Rate (CFM)	Available External Static Pressure (in. wg)														
	0.2			0.4			0.6			0.8			1.0		
	RPM	KWI	BHP	RPM	KWI	BHP	RPM	KWI	BHP	RPM	KWI	BHP	RPM	KWI	BHP
2250	511	0.44	0.48	591	0.61	0.66	660	0.80	0.86	722	1.00	1.07	779	0.82	0.89
2438	540	0.54	0.58	616	0.71	0.77	683	0.91	0.97	743	1.12	1.20	799	0.94	1.02
2625	569	0.64	0.68	642	0.83	0.89	706	1.03	1.11	765	1.24	1.34	819	1.06	1.15
2813	599	0.76	0.81	669	0.96	1.03	731	1.17	1.25	788	1.38	1.49	841	1.19	1.30
3000	630	0.89	0.95	696	1.10	1.18	756	1.31	1.42	811	1.54	1.67	863	1.34	1.46
3188	661	1.03	1.11	724	1.26	1.35	782	1.48	1.60	836	1.72	1.86	886	1.50	1.63
3375	692	1.20	1.29	753	1.42	1.54	808	1.66	1.80	861	1.91	2.08	910	1.67	1.82
3563	723	1.38	1.49	782	1.61	1.75	836	1.87	2.03	887	2.12	2.30			
3750	755	1.57	1.70	811	1.82	1.98	864	2.09	2.27						

Unit 50TCM - D08 - 7.5 Tons - 400V - 50Hz (Continued)

Air Flow Rate (CFM)	Available External Static Pressure (in. wg)														
	1.2			1.4			1.6			1.8			2.0		
	RPM	KWI	BHP	RPM	KWI	BHP	RPM	KWI	BHP	RPM	KWI	BHP	RPM	KWI	BHP
2250	832	1.42	1.54	882	1.65	1.79	928	1.90	2.06						
2438	851	1.55	1.68	899	1.79	1.94									
2625	870	1.69	1.84	918	1.94	2.11									
2813	890	1.86	2.02												
3000	912	2.04	2.21												
3188															
3375															
3563															
3750															

Legend:

Normal Font - Field Installed Drive Package

Bold Font - Standard Drive Package + Standard Motor.

Italics Font - Medium Drive Package + Medium Static Motor.

RPM - Revolutions Per Minute

KWI - Kilo Watts Input to Motor

BHP - Brake Horsepower Input to Fan

CFM - Cubic Feet per Minute

in.wg - Inch Water Gage

Notes:

- Do not adjust motor rpm such that motor maximum bhp and/or watts is exceeded at the maximum operatin cfm.
- Static Pressure (i.e Filters) must be added to external static pressure before entering fan performance table.
- Interpolation is permissible. Do not extrapolate.
- Fan performance is based on wet coils, clean filters and casing losses.
- Extensive motor and drive testing on these units ensures that the full brake horsepower and watts range of the motor can be utilized with confidence. Using your fan motors up to the watts or bhp rating shown will not result in nuisance tripping or premature motor failure. Unit warranty will not be affected.
- Bold data shows the range of air flow rate for unit management system, other rpms require field-supplied drive.
- Use of field-supplied motor may affect wiring size. Contact your Carrier representative for details.
- Conversion - Bhp to KWI

$$\text{KWI} = \frac{\text{Bhp} \times 0.746}{\text{Motor efficiency}}$$

Fan Performance Table (Continued)

Unit 50TCM - D09 - 8.5 Tons - 400V - 50Hz

Air Flow Rate (CFM)	Available External Static Pressure (in. wg)														
	0.2			0.4			0.6			0.8			1.0		
	RPM	KWI	BHP	RPM	KWI	BHP	RPM	KWI	BHP	RPM	KWI	BHP	RPM	KWI	BHP
2550	477	0.42	0.45	556	0.56	0.60	624	0.69	0.74	685	0.83	0.89	742	0.95	1.03
2763	503	0.51	0.54	578	0.65	0.70	644	0.80	0.86	704	0.95	1.01	759	1.09	1.18
2975	529	0.60	0.65	601	0.77	0.83	665	0.93	0.99	724	1.08	1.16	777	1.23	1.34
3188	556	0.72	0.77	625	0.90	0.96	687	1.06	1.14	744	1.21	1.32	796	1.39	1.50
3400	583	0.86	0.92	650	1.03	1.11	710	1.21	1.30	765	1.38	1.49	<i>816</i>	<i>1.56</i>	<i>1.69</i>
3613	611	1.00	1.08	675	1.19	1.27	733	1.38	1.48	787	1.55	1.68	<i>836</i>	<i>1.74</i>	<i>1.89</i>
3825	639	1.16	1.24	701	1.36	1.46	757	1.55	1.68	808	1.74	1.89	<i>857</i>	<i>1.94</i>	<i>2.11</i>
3950	668	1.34	1.44	727	1.56	1.67	781	1.74	1.89	<i>832</i>	<i>1.95</i>	<i>2.12</i>	<i>879</i>	<i>2.17</i>	<i>2.35</i>
4250	696	1.54	1.65	753	1.74	1.89	<i>806</i>	<i>1.96</i>	<i>2.13</i>	<i>855</i>	<i>2.18</i>	<i>2.37</i>			

Unit 50TCM - D09 - 8.5 Tons - 400V - 50Hz (Continued)

Air Flow Rate (CFM)	Available External Static Pressure (in. wg)														
	1.2			1.4			1.6			1.8			2.0		
	RPM	KWI	BHP	RPM	KWI	BHP	RPM	KWI	BHP	RPM	KWI	BHP	RPM	KWI	BHP
2550	794	1.10	1.19	842	1.24	1.35	888	1.39	1.50	932	1.53	1.66			
2763	810	1.23	1.34	858	1.39	1.50	903	1.54	1.67						
2975	827	1.39	1.50	874	1.55	1.68	919	1.71	1.86						
3188	845	1.56	1.69	891	1.72	1.87									
3400	864	1.73	1.88	909	1.92	2.08									
3613	883	1.93	2.10	928	2.13	2.31									
3825	903	2.15	2.33												
3950															
4250															

Unit 50TCM - D12 - 10 Tons - 400V - 50Hz

Air Flow Rate (CFM)	Available External Static Pressure (in. wg)														
	0.2			0.4			0.6			0.8			1.0		
	RPM	KWI	BHP	RPM	KWI	BHP	RPM	KWI	BHP	RPM	KWI	BHP	RPM	KWI	BHP
3000	556	0.66	0.72	623	0.81	0.88	684	0.96	1.05	738	1.12	1.22	789	1.28	1.39
3250	590	0.80	0.87	655	0.97	1.06	713	1.14	1.24	766	1.31	1.42	815	1.48	1.61
3500	625	0.97	1.06	687	1.15	1.25	742	1.34	1.45	794	1.52	1.65	841	1.70	1.85
3750	661	1.18	1.28	719	1.37	1.49	773	1.56	1.69	822	1.75	1.90	869	1.96	2.12
4000	697	1.39	1.51	753	1.60	1.74	804	1.81	1.97	852	2.02	2.19	897	2.23	2.42
4250	733	1.64	1.78	787	1.84	2.00	836	2.09	2.27	883	2.31	2.51	926	2.52	2.74
4500	770	1.91	2.08	821	2.16	2.34	869	2.39	2.60	914	2.62	2.85	956	2.86	3.10

Unit 50TCM - D12 - 10 Tons - 400V - 50Hz (Continued)

Air Flow Rate (CFM)	Available External Static Pressure (in. wg)														
	1.2			1.4			1.6			1.8			2.0		
	RPM	KWI	BHP	RPM	KWI	BHP	RPM	KWI	BHP	RPM	KWI	BHP	RPM	KWI	BHP
3000	836	1.44	1.56	881	1.59	1.73	923	1.75	1.90	963	1.91	2.08	1001	2.08	2.26
3250	861	1.65	1.79	904	1.81	1.97	945	1.99	2.16	985	2.16	2.34	1023	2.33	2.53
3500	886	1.88	2.05	929	2.07	2.24	969	2.25	2.44	1008	2.43	2.64	1045	2.61	2.84
3750	912	2.15	2.33	954	2.34	2.54	994	2.53	2.75	1031	2.74	2.97	<i>1068</i>	<i>2.93</i>	<i>3.18</i>
4000	940	2.43	2.64	980	2.64	2.87	1019	2.85	3.09	<i>1056</i>	<i>3.06</i>	<i>3.32</i>	<i>1092</i>	<i>3.26</i>	<i>3.54</i>
4250	968	2.75	2.98	1007	2.97	3.22	1045	3.19	3.47	<i>1081</i>	<i>3.40</i>	<i>3.70</i>	<i>1117</i>	<i>3.63</i>	<i>3.94</i>
4500	996	3.09	3.36	1035	3.32	3.61	1072	3.56	3.86	1108	3.79	4.11			

Legend:

Normal Font - Field Installed Drive Package

Bold Font - Standard Drive Package + Standard Motor.

Italics Font - Medium Drive Package + Medium Static Motor.

RPM - Revolutions Per Minute

KWI - Kilo Watts Input to Motor

BHP - Brake Horsepower Input to Fan

CFM - Cubic Feet per Minute

in.wg - Inch Water Gage

Notes:

1. Do not adjust motor rpm such that motor maximum bhp and/or watts is exceeded at the maximum operatin cfm.
2. Static Pressure (i.e Filters) must be added to external static pressure before entering fan performance table.
3. Interpolation is permissible. Do not extrapolate.
4. Fan performance is based on wet coils, clean filters and casing losses.
5. Extensive motor and drive testing on these units ensures that the full brake horsepower and watts range of the motor can be utilized with confidence. Using your fan motors up to the watts or bhp rating shown will not result in nuisance tripping or premature motor failure. Unit warranty will not be affected.
6. Bold data shows the range of air flow rate for unit management system, other rpms require field-supplied drive.
7. Use of field-supplied motor may affect wiring size. Contact your Carrier representative for details.
8. Conversion - Bhp to KWI

$$KWI = \frac{Bhp \times 0.746}{\text{Motor efficiency}}$$

Fan Performance Table (Continued)

Unit 50TCM - D13 - 11 Tons - 400V - 50Hz

Air Flow Rate (CFM)	Available External Static Pressure (in. wg)														
	0.2			0.4			0.6			0.8			1.0		
	RPM	KWI	BHP	RPM	KWI	BHP	RPM	KWI	BHP	RPM	KWI	BHP	RPM	KWI	BHP
3700	621	0.98	1.06	679	1.15	1.25	734	1.33	1.44	786	1.51	1.64	837	1.70	1.84
4063	665	1.21	1.32	717	1.39	1.51	769	1.58	1.72	818	1.78	1.94	866	1.98	2.15
4375	706	1.48	1.61	757	1.68	1.82	805	1.88	2.04	852	2.09	2.27	897	2.31	2.50
4688	749	1.79	1.95	797	2.00	2.17	843	2.21	2.40	887	2.44	2.65	930	2.67	2.89
5000	793	2.14	2.33	838	2.37	2.58	881	2.60	2.82	923	2.83	3.07	965	3.06	3.33
5313	837	2.55	2.77	880	2.78	3.02	921	3.03	3.29	961	3.26	3.54	1000	3.52	3.82
5700	882	3.00	3.25	922	3.24	3.52	961	3.49	3.79						

Unit 50TCM - D13 - 11 Tons - 400V - 50Hz (Continued)

Air Flow Rate (CFM)	Available External Static Pressure (in. wg)														
	1.2			1.4			1.6			1.8			2.0		
	RPM	KWI	BHP	RPM	KWI	BHP	RPM	KWI	BHP	RPM	KWI	BHP	RPM	KWI	BHP
3700	885	1.89	2.05	932	2.09	2.27	978	2.30	2.49	1022	2.50	2.72			
4063	912	2.19	2.38	957	2.40	2.61	1001	2.61	2.83	1043	2.83	3.07			
4375	941	2.52	2.74	984	2.74	2.98	1026	2.97	3.22						
4688	972	2.89	3.14	1013	3.12	3.39									
5000	1005	3.31	3.59	1044	3.55	3.85									
5313															
5700															

Legend:

Normal Font - Field Installed Drive Package

Bold Font - Standard Drive Package + Standard Motor.

Italics Font - Medium Drive Package + Medium Static Motor.

RPM - Revolutions Per Minute

KWI - Kilo Watts Input to Motor

BHP - Brake Horsepower Input to Fan

CFM - Cubic Feet per Minute

in.wg - Inch Water Gage

Notes:

- Do not adjust motor rpm such that motor maximum bhp and/or watts is exceeded at the maximum operatin cfm.
- Static Pressure (i.e Filters) must be added to external static pressure before entering fan performance table.
- Interpolation is permissible. Do not extrapolate.
- Fan performance is based on wet coils, clean filters and casing loses.
- Extensive motor and drive testing on these units ensures that the full brake horsepower and watts range of the motor can be utilized with confidence. Using your fan motors up to the watt or bhp rating shown will not result in nuisance tripping or premature motor failure. Unit warranty will not be affected.
- Bold data shows the range of air flow rate for unit management system, other rpms require field-supplied drive.
- Use of field-supplied motor may affect wiring size. Contact your Carrier representative for details.
- Conversion - Bhp to KWI

$$KWI = \frac{Bhp \times 0.746}{\text{Motor efficiency}}$$

Fan RPM at Motor Pulley Settings

Freq.	Unit 50TCM	Drive Package	MOTOR PULLEY TURNS OPEN - ENGLISH										
			0	1/3	1	1 1/3	2	2 1/3	3	3 1/3	4	4 1/3	5
50Hz	A07	Standard Static	1211	1176	1140	1104	1069	1033	998	962	926	891	855
		Medium Static	1449	1362	1330	1298	1267	1235	1203	1172	1140	1108	1077
	D08	Standard Static	808	784	760	736	713	689	665	641	618	594	570
		Medium Static	932	875	855	835	814	794	774	753	733	713	692
	D09	Standard Static	808	784	760	736	713	689	665	641	618	594	570
		Medium Static	932	875	855	835	814	794	774	753	733	713	692
	D12	Standard Static	808	784	760	736	713	689	665	641	618	594	570
		Medium Static	1087	1021	998	974	950	926	903	879	855	831	808
	D13	Standard Static	903	876	848	821	794	767	739	712	685	657	630
		Medium Static	1056	998	980	962	944	926	908	891	873	855	837

Freq.	Unit 50TCM	Drive Package	MOTOR PULLEY TURNS OPEN - SI										
			0	1/3	1	1 1/3	2	2 1/3	3	3 1/3	4	4 1/3	5
50Hz	A07	Standard Static	20.2	19.6	19.0	18.4	17.8	17.2	16.6	16.0	15.4	14.8	14.3
		Medium Static	24.2	22.7	22.2	21.6	21.1	20.6	20.1	19.5	19.0	18.5	17.9
	D08	Standard Static	13.5	13.1	12.7	12.3	11.9	11.5	11.1	10.7	10.3	9.9	9.5
		Medium Static	15.5	14.6	14.3	13.9	13.6	13.2	12.9	12.6	12.2	11.9	11.5
	D09	Standard Static	13.5	13.1	12.7	12.3	11.9	11.5	11.1	10.7	10.3	9.9	9.5
		Medium Static	15.5	14.6	14.3	13.9	13.6	13.2	12.9	12.6	12.2	11.9	11.5
	D12	Standard Static	13.5	13.1	12.7	12.3	11.9	11.5	11.1	10.7	10.3	9.9	9.5
		Medium Static	18.1	17.0	16.6	16.2	15.8	15.4	15.0	14.6	14.3	13.9	13.5
	D13	Standard Static	15.1	14.6	14.1	13.7	13.2	12.8	12.3	11.9	11.4	11.0	10.5
		Medium Static	17.6	16.6	16.3	16.0	15.7	15.4	15.1	14.8	14.5	14.3	14.0

Bold, Italics RPM is the factory setting . In range of +- 5 %.

The standard belt size may not cover all the above range. Other RPMs require field supplied drive package.

Sound Rating Data

Unit 50TCM	Cooling Stages	Unit Sound (dB) - Based on cooling mode								
		A-Weighted	63	125	250	500	1000	2000	4000	8000
A07	1	83.8	90.8	85.7	83.0	81.8	79.1	73.6	70.1	65.4
D08	2	83.2	90.4	84.4	82.7	81.1	78.6	73.2	69.5	65.1
D09	2	84.3	91.8	85.2	83.6	82.1	79.7	74.2	70.8	66.9
D12	2	90.2	95.3	88.7	85.7	86.1	85.2	83.1	79.5	76.2
D13	2	92.0	95.4	90.3	89.5	88.6	87.2	83.6	82.1	78.1

dB – Decibel

NOTES:

1. Measurements are expressed in terms of sound power. Do not compare these values to sound pressure values because sound pressure accounts for specific environment factors which do not match individual applications. Sound power values are independent of the environment and therefore more accurate.

2. A-Weighted sound ratings filter out very high and very low frequencies, to better approximate the response of an "average" human ear.

Electrical Data

50TCM			Compressor				OFM			IFM		Electric Heater			MCA	MOCP
Unit Size	Drive package Indoor Motor	Power Supply V / Ph / Hz	No.1		No.2		Qty	HP	FLA	HP	FLA	Heater P.N	Application (KW)	FLA		
			RLA	LRA	RLA	LRA										
A07	Standard	400/3/50 - 415/3/50	9.74	64.0	-	-	1	1/3	2.4	1.4	2.6	-	-	-	17.2	25
			9.74	64.0	-	-	1	1/3	2.4	1.4	2.6	CRHEATER106A00	4.2	6.0	17.5	25
			9.74	64.0	-	-	1	1/3	2.4	1.4	2.6	CRHEATER108A00	8.0	11.5	17.6	25
			9.74	64.0	-	-	1	1/3	2.4	1.4	2.6	CRHEATER109A00	9.7	14.0	20.8	25
			9.74	64.0	-	-	1	1/3	2.4	1.4	2.6	CRHEATER108A00,108A00	16.0	23.1	32.1	40
			9.74	64.0	-	-	1	1/3	2.4	1.4	2.6	CRHEATER108A00,109A00	17.7	25.6	35.3	40
	Medium	400/3/50 - 415/3/50	9.74	64.0	-	-	1	1/3	1.6	2.9	4.5	-	0	0.0	18.3	25
			9.74	64.0	-	-	1	1/3	1.6	2.9	4.5	CRHEATER106A00	4.2	6.0	18.3	25
			9.74	64.0	-	-	1	1/3	1.6	2.9	4.5	CRHEATER108A00	8.0	11.5	20.0	25
			9.74	64.0	-	-	1	1/3	1.6	2.9	4.5	CRHEATER109A00	9.7	14.0	23.1	25
			9.74	64.0	-	-	1	1/3	1.6	2.9	4.5	CRHEATER108A00,108A00	16.0	23.1	34.5	35
			9.74	64.0	-	-	1	1/3	1.6	2.9	4.5	CRHEATER108A00,109A00	17.7	25.6	37.6	40
D08	Standard	400/3/50 - 415/3/50	6.1	43.0	6.1	43.0	2	1/3	1.4	2.4	3	-	-	-	19.5	25
			6.1	43.0	6.1	43.0	2	1/3	1.4	2.4	3	CRHEATER116A00	9.7	13.9	21.1	25
			6.1	43.0	6.1	43.0	2	1/3	1.4	2.4	3	CRHEATER113A00	11.5	16.5	24.5	25
			6.1	43.0	6.1	43.0	2	1/3	1.4	2.4	3	CRHEATER114A00	19.3	27.9	38.6	40
			6.1	43.0	6.1	43.0	2	1/3	1.4	2.4	3	CRHEATER115A00	22.9	33.1	45.1	50
			6.1	43.0	6.1	43.0	2	1/3	1.4	2.4	3	CRHEATER114A00,116A00	29.0	41.8	56.0	60
	Medium	400/3/50 - 415/3/50	6.1	43.0	6.1	43.0	2	1/3	1.4	2.9	4.5	-	-	-	21.0	25
			6.1	43.0	6.1	43.0	2	1/3	1.4	2.9	4.5	CRHEATER116A00	9.7	13.9	23.0	25
			6.1	43.0	6.1	43.0	2	1/3	1.4	2.9	4.5	CRHEATER113A00	11.5	16.5	26.3	30
			6.1	43.0	6.1	43.0	2	1/3	1.4	2.9	4.5	CRHEATER114A00	19.3	27.9	40.5	50
			6.1	43.0	6.1	43.0	2	1/3	1.4	2.9	4.5	CRHEATER115A00	22.9	33.1	47.0	50
			6.1	43.0	6.1	43.0	2	1/3	1.4	2.9	4.5	CRHEATER114A00,116A00	29.0	41.8	58.0	60
D09	Standard	400/3/50 - 415/3/50	6.8	51.5	6.2	52.0	1	1	3.4	2.4	3	-	0	0.0	21.1	25
			6.8	51.5	6.2	52.0	1	1	3.4	2.4	3	CRHEATER116A00	9.7	13.9	21.1	25
			6.8	51.5	6.2	52.0	1	1	3.4	2.4	3	CRHEATER113A00	11.5	16.5	24.5	25
			6.8	51.5	6.2	52.0	1	1	3.4	2.4	3	CRHEATER114A00	19.3	27.9	38.6	40
			6.8	51.5	6.2	52.0	1	1	3.4	2.4	3	CRHEATER115A00	22.9	33.1	45.1	50
			6.8	51.5	6.2	52.0	1	1	3.4	2.4	3	CRHEATER114A00,116A00	29.0	41.8	56.0	60
	Medium	400/3/50 - 415/3/50	6.8	51.5	6.2	52.0	1	1	3.4	2.9	4.5	-	-	-	22.6	30
			6.8	51.5	6.2	52.0	1	1	3.4	2.9	4.5	CRHEATER116A00	9.7	13.9	23.0	30
			6.8	51.5	6.2	52.0	1	1	3.4	2.9	4.5	CRHEATER113A00	11.5	16.5	26.3	30
			6.8	51.5	6.2	52.0	1	1	3.4	2.9	4.5	CRHEATER114A00	19.3	27.9	40.5	50
			6.8	51.5	6.2	52.0	1	1	3.4	2.9	4.5	CRHEATER115A00	22.9	33.1	47.0	50
			6.8	51.5	6.2	52.0	1	1	3.4	2.9	4.5	CRHEATER114A00,116A00	29.0	41.8	57.9	60

Legend and Notes for Electrical Data Table

- FLA - Full Load Amps
- IFM - Indoor (Evaporator) Fan Motor
- LRA - Locked Rotor Amps
- MCA - Minimum Circuit Amps
- Minimum Voltage: 360V , Maximum Voltage: 440V on 400/3/50
- OFM - Outdoor (Condenser) Fan Motor
- RLA - Rated Load Amps
- APP - Application power at rated power supply voltage
- MOCP - Maximum Overcurrent Protection

Unbalanced 3-Phase Supply Voltage

Never operate a motor where phase imbalance in supply voltage is greater than 2%.

Use the following formula to determine the percentage of voltage imbalance

$$= 100 \times \frac{\text{Maximum Deviation From Average Voltage}}{\text{Average Voltage}}$$

Determine maximum deviation from average voltage.

- (AB) 397 - 392 =5v
- (BC) 404 - 397 =7v
- (AC) 457 - 397 =2v

Maximum Deviation is 7v.

Determine Percentage Voltage Imbalance.

$$\% \text{ Voltage Imbalance} = 100 \times \frac{7}{397} = 1.76\%$$

AB = 392v	Average Voltage = $\frac{392 + 404 + 395}{3}$
BC = 404v	
AC = 395v	$= \frac{1191}{3} = 397V$

This amount of phase imbalance is satisfactory as it is below the maximum allowable 2%

IMPORTANT: If the supply voltage phase imbalance is more than 2% contact your local electric utility company

Electrical Data (Continued)

50TCM			Compressor				OFM			IFM		Electric Heater			MCA	MOCP
Unit Size	Drive package Indoor Motor	Power Supply V / Ph / Hz	No.1		No.2		Qty	HP	FLA	HP	FLA	Heater P.N	Application (KW)	FLA		
			RLA	LRA	RLA	LRA										
D12	Standard	400/3/50 - 415/3/50	7.8	51.5	7.8	51.5	1	1	3.4	2.4	3	-	-	-	24.0	30
			7.8	51.5	7.8	51.5	1	1	3.4	2.4	3	CRHEATER116A00	9.7	13.9	24.0	30
			7.8	51.5	7.8	51.5	1	1	3.4	2.4	3	CRHEATER113A00	11.5	16.5	24.4	30
			7.8	51.5	7.8	51.5	1	1	3.4	2.4	3	CRHEATER114A00	19.3	27.9	38.6	40
			7.8	51.5	7.8	51.5	1	1	3.4	2.4	3	CRHEATER115A00	22.9	33.1	45.1	50
			7.8	51.5	7.8	51.5	1	1	3.4	2.4	3	CRHEATER114A00,116A00	29	41.8	56.0	60
	Medium	400/3/50 - 415/3/50	7.8	51.5	7.8	51.5	1	1	3.4	3.7	4.4	-	0	0.0	25.4	30
			7.8	51.5	7.8	51.5	1	1	3.4	3.7	4.4	CRHEATER116A00	9.7	13.9	25.4	30
			7.8	51.5	7.8	51.5	1	1	3.4	3.7	4.4	CRHEATER113A00	11.5	16.5	26.1	30
			7.8	51.5	7.8	51.5	1	1	3.4	3.7	4.4	CRHEATER114A00	19.3	27.9	40.4	50
			7.8	51.5	7.8	51.5	1	1	3.4	3.7	4.4	CRHEATER115A00	22.9	33.1	46.9	50
			7.8	51.5	7.8	51.5	1	1	3.4	3.7	4.4	CRHEATER114A00,116A00	29	41.8	57.8	60
D13	Standard	400/3/50 - 415/3/50	10.6	75	11	75	1	1	7	2.9	3.91	-	-	-	24.2	30
			10.6	75	11	75	1	1	7	2.9	3.91	CRHEATER116A00	9.7	13.9	24.2	30
			10.6	75	11	75	1	1	7	2.9	3.91	CRHEATER113A00	11.5	16.5	24.2	30
			10.6	75	11	75	1	1	7	2.9	3.91	CRHEATER114A00	19.3	27.9	24.2	30
			10.6	75	11	75	1	1	7	2.9	3.91	CRHEATER115A00	22.9	33.1	24.2	40
			10.6	75	11	75	1	1	7	2.9	3.91	CRHEATER114A00,116A00	29	41.8	24.2	50
	Medium	400/3/50 - 415/3/50	10.6	75	11	75	1	1	7	3.9	7.5	-	-	-	27.8	30
			10.6	75	11	75	1	1	7	3.9	7.5	CRHEATER116A00	9.7	13.9	27.8	30
			10.6	75	11	75	1	1	7	3.9	7.5	CRHEATER113A00	11.5	16.5	27.8	30
			10.6	75	11	75	1	1	7	3.9	7.5	CRHEATER114A00	19.3	27.9	27.8	40
			10.6	75	11	75	1	1	7	3.9	7.5	CRHEATER115A00	22.9	33.1	27.8	40
			10.6	75	11	75	1	1	7	3.9	7.5	CRHEATER114A00,116A00	29	41.8	27.8	50

Legend and Notes for Electrical Data Table

- FLA - Full Load Amps
- IFM - Indoor (Evaporator) Fan Motor
- LRA - Locked Rotor Amps
- MCA - Minimum Circuit Amps
- Minimum Voltage: 360V , Maximum Voltage: 440V on 400/3/50
- OFM - Outdoor (Condenser) Fan Motor
- RLA - Rated Load Amps
- APP - Application power at rated power supply voltage
- MOCP - Maximum Overcurrent Protection

Unbalanced 3-Phase Supply Voltage

Never operate a motor where phase imbalance in supply voltage is greater than 2%.

Use the following formula to determine the percentage of voltage imbalance

$$= 100 \times \frac{\text{Maximum Deviation From Average Voltage}}{\text{Average Voltage}}$$

Determine maximum deviation from average voltage.

- (AB) 397 - 392 =5v
- (BC) 404 - 397 =7v
- (AC) 457 - 397 =2v

Maximum Deviation is 7v.

AB = 392v	Average Voltage = $\frac{392 + 404 + 395}{3}$
BC = 404v	
AC = 395v	$= \frac{1191}{3} = 397V$

Determine Percentage Voltage Imbalance.

$$\% \text{ Voltage Imbalance} = 100 \times \frac{7}{397} = 1.76\%$$

This amount of phase imbalance is satisfactory as it is below the maximum allowable 2%

IMPORTANT: If the supply voltage phase imbalance is more than 2% contact your local electric utility company

Typical Wiring Schematic - Series A - 50TCMA07

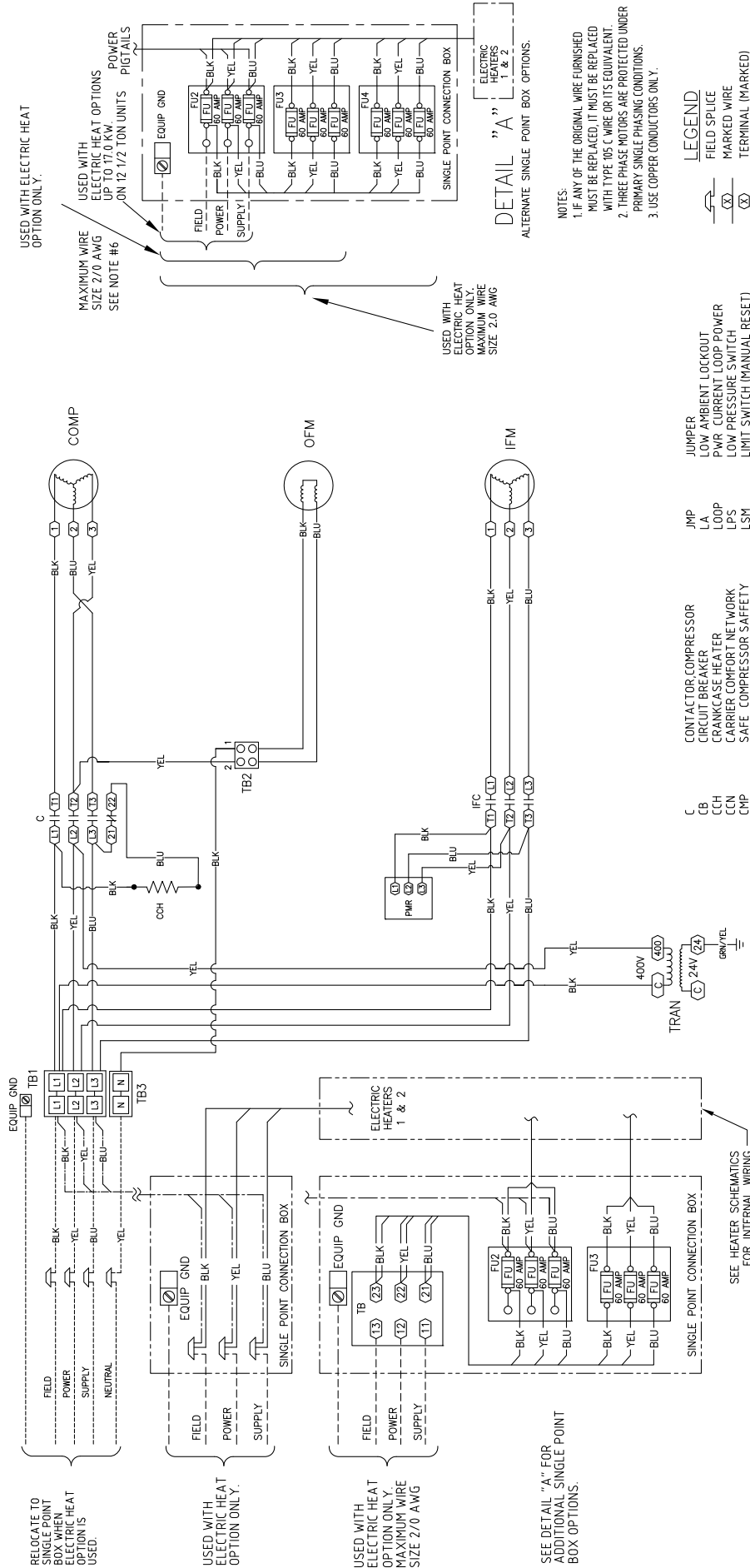

- NOTES:**
1. IF ANY OF THE ORIGINAL WIRE FURNISHED MUST BE REPLACED, IT MUST BE REPLACED WITH TYPE 105 °C WIRE OR ITS EQUIVALENT.
 2. THREE PHASE MOTORS ARE PROTECTED UNDER PRIMARY SINGLE PHASING CONDITIONS.
 3. USE COPPER CONDUCTORS ONLY.

LEGEND

- JUMPER
- LOW AMBIENT LOCKOUT
- PWR CURRENT LOOP POWER
- LOW PRESSURE SWITCH
- LIMIT SWITCH (MANUAL RESET)
- LIMIT SWITCH
- OUTDOOR AIR QUALITY
- OUTDOOR AIR TEMP SEN
- OUTDOOR FAN MOTOR
- OVERLOAD
- PLUG ASSEMBLY
- POTENTIOMETER
- PHASE MONITOR RELAY
- QUADRUPLE TERMINAL RELAY
- RETURN AIR TEMP SEN
- REMOTE OCCUPANCY
- SUPPLY AIR TEMP. SENSOR
- SENSOR
- SET POINT OFFSET
- SUPPLY FAN STATUS
- TIME DELAY RELAY (WINTER START)
- TRANSFORMER
- VARIABLE FREQUENCY DRIVE

- JMP JUMPER
- LA LOW AMBIENT LOCKOUT
- PWR CURRENT LOOP POWER
- LPS LOW PRESSURE SWITCH
- LSM LIMIT SWITCH (MANUAL RESET)
- LS LIMIT SWITCH
- DAQ OUTDOOR AIR QUALITY
- OAT OUTDOOR AIR TEMP SEN
- OFM OUTDOOR FAN MOTOR
- OL OVERLOAD
- PL PLUG ASSEMBLY
- POT POTENTIOMETER
- PMR PHASE MONITOR RELAY
- QTR QUADRUPLE TERMINAL RELAY
- RAT RETURN AIR TEMP SEN
- ROCC REMOTE OCCUPANCY
- SAT SUPPLY AIR TEMP. SENSOR
- SEN SENSOR
- SPO SET POINT OFFSET
- SFS SUPPLY FAN STATUS
- TDR TIME DELAY RELAY (WINTER START)
- TRN TRANSFORMER
- VFD VARIABLE FREQUENCY DRIVE

- IMP IMP
- LA LA
- LOOP LOOP
- LPS LPS
- LSM LSM
- LS LS
- DAQ DAQ
- OAT OAT
- OFM OFM
- OL OL
- PL PL
- POT POT
- PMR PMR
- QTR QTR
- RAT RAT
- ROCC ROCC
- SAT SAT
- SEN SEN
- SPO SPO
- SFS SFS
- TDR TDR
- TRN TRN
- VFD VFD

- C CONTACTOR/COMPRESSOR
- CB CIRCUIT BREAKER
- CCH CRANKCASE HEATER
- CCN CARRIER COMPFORT NETWORK
- CCM SAFE COMPRESSOR SAFETY
- COFS CONDENSATE OVERFLOW SWT
- COMP COMPRESSOR MOTOR
- CR CENTRAL RELAY
- CTB CENTRAL TERMINAL BOARD
- DDC DIRECT DIGITAL CONTROL
- ERV ENERGY RECOVERY VENTILATOR
- FAC FACTORY INSTALLED OPTION
- FSH FIRE SHUT DOWN
- FUSE FUSE
- GND GROUND
- HC HEATER CONTACTOR
- HPS HIGH PRESSURE SWITCH
- IQA INDOOR AIR QUALITY SENSORS
- IAC INDOOR FAN CONTACTOR
- IFCB INDOOR FAN CIRCUIT BREAKER
- IFTB INDOOR FAN TERMINAL BLOCK
- IFM INDOOR FAN MOTOR
- IRH INDOOR RELATIVE HUMIDITY

- C CONTACTOR/COMPRESSOR
- CB CIRCUIT BREAKER
- CCH CRANKCASE HEATER
- CCN CARRIER COMPFORT NETWORK
- CCM SAFE COMPRESSOR SAFETY
- COFS CONDENSATE OVERFLOW SWT
- COMP COMPRESSOR MOTOR
- CR CENTRAL RELAY
- CTB CENTRAL TERMINAL BOARD
- DDC DIRECT DIGITAL CONTROL
- ERV ENERGY RECOVERY VENTILATOR
- FAC FACTORY INSTALLED OPTION
- FSH FIRE SHUT DOWN
- FUSE FUSE
- GND GROUND
- HC HEATER CONTACTOR
- HPS HIGH PRESSURE SWITCH
- IQA INDOOR AIR QUALITY SENSORS
- IAC INDOOR FAN CONTACTOR
- IFCB INDOOR FAN CIRCUIT BREAKER
- IFTB INDOOR FAN TERMINAL BLOCK
- IFM INDOOR FAN MOTOR
- IRH INDOOR RELATIVE HUMIDITY

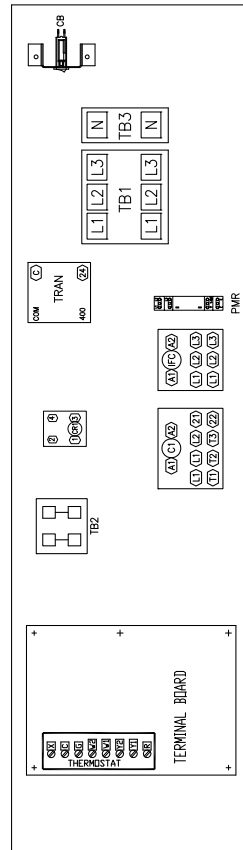

Typical Wiring Schematic - Series A - 50TCMA08

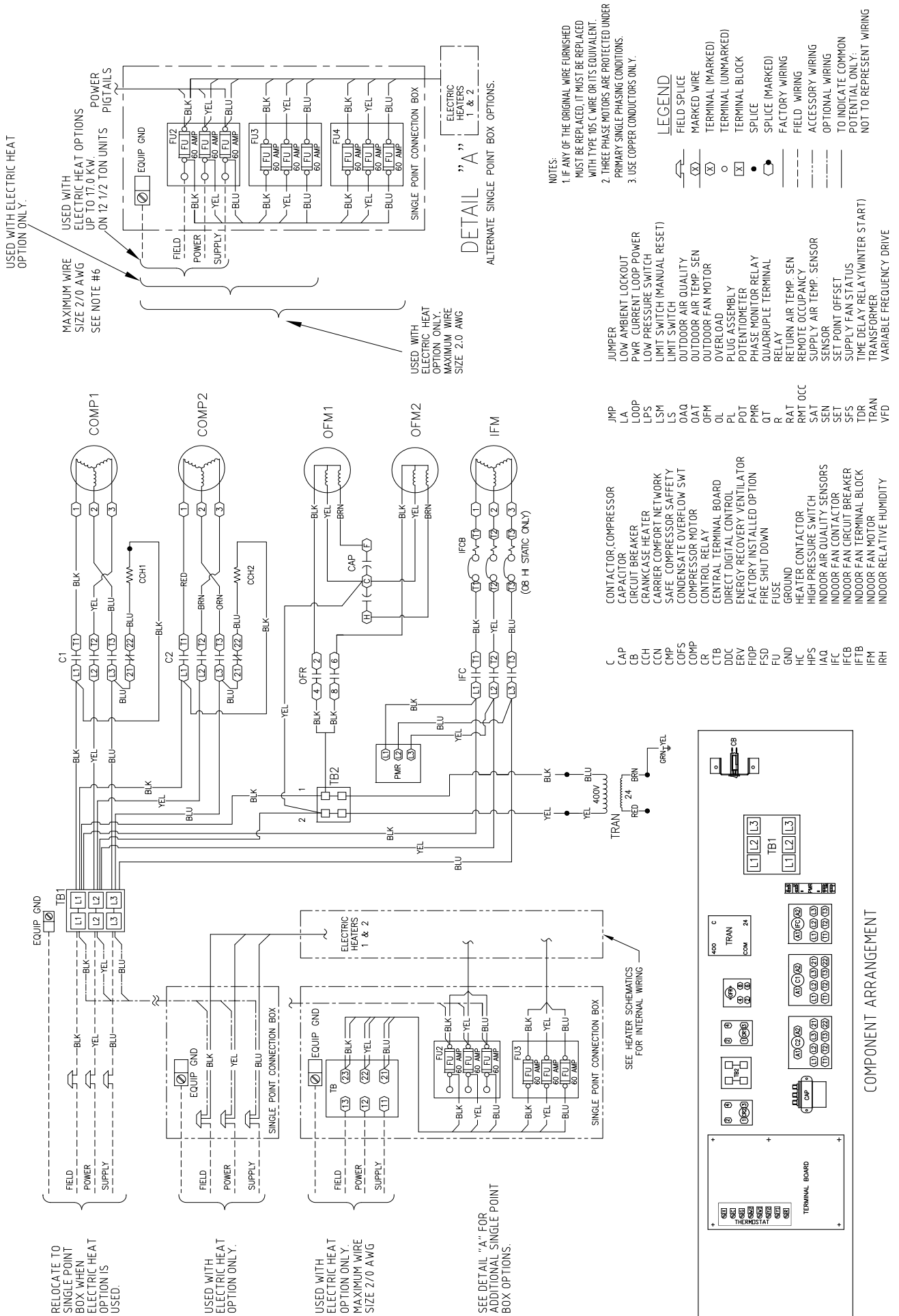

Typical Wiring Schematic - Series A - 50TCMA09/12

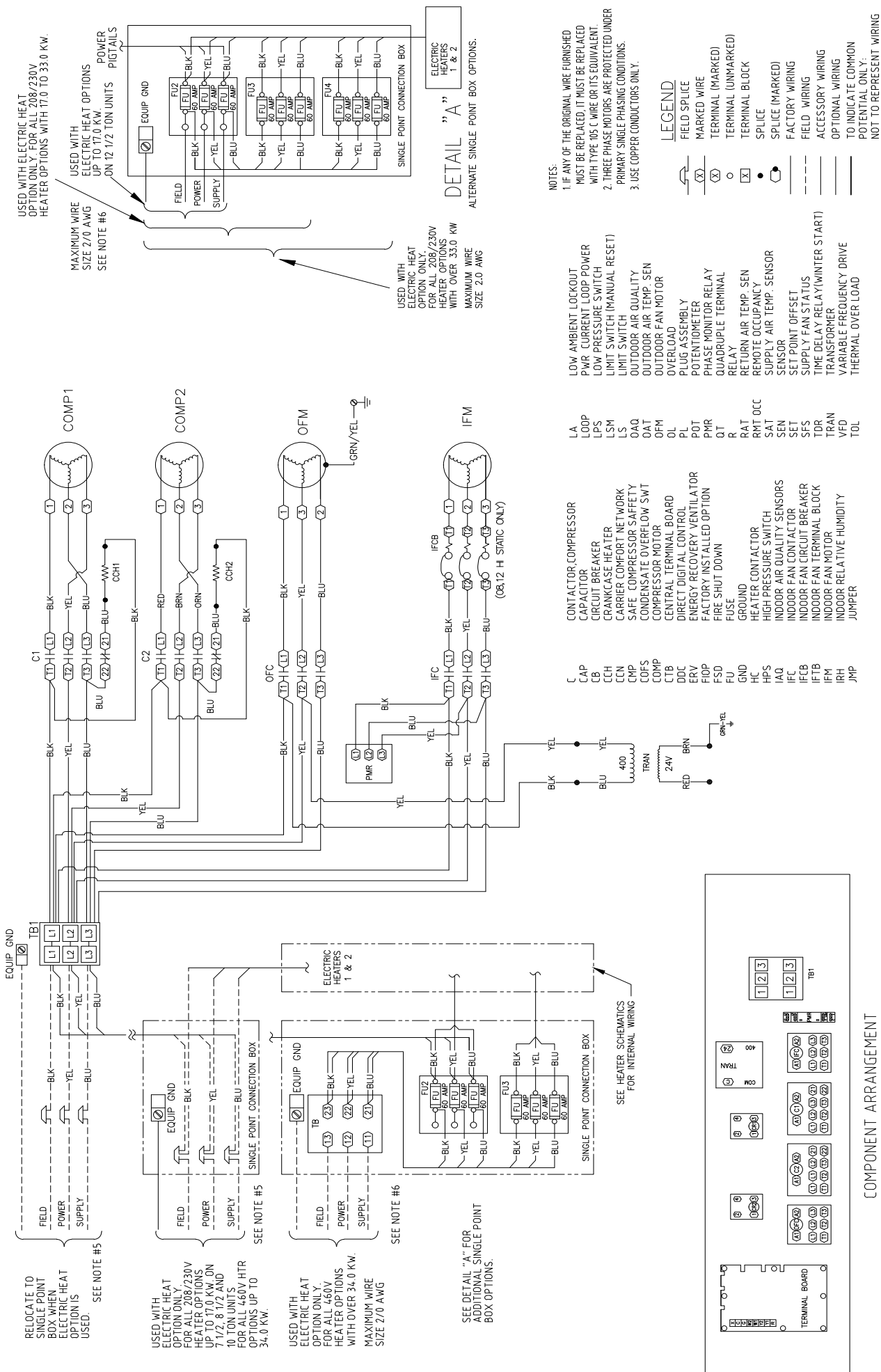

Typical Wiring Schematic - Series A - 50TCMA13

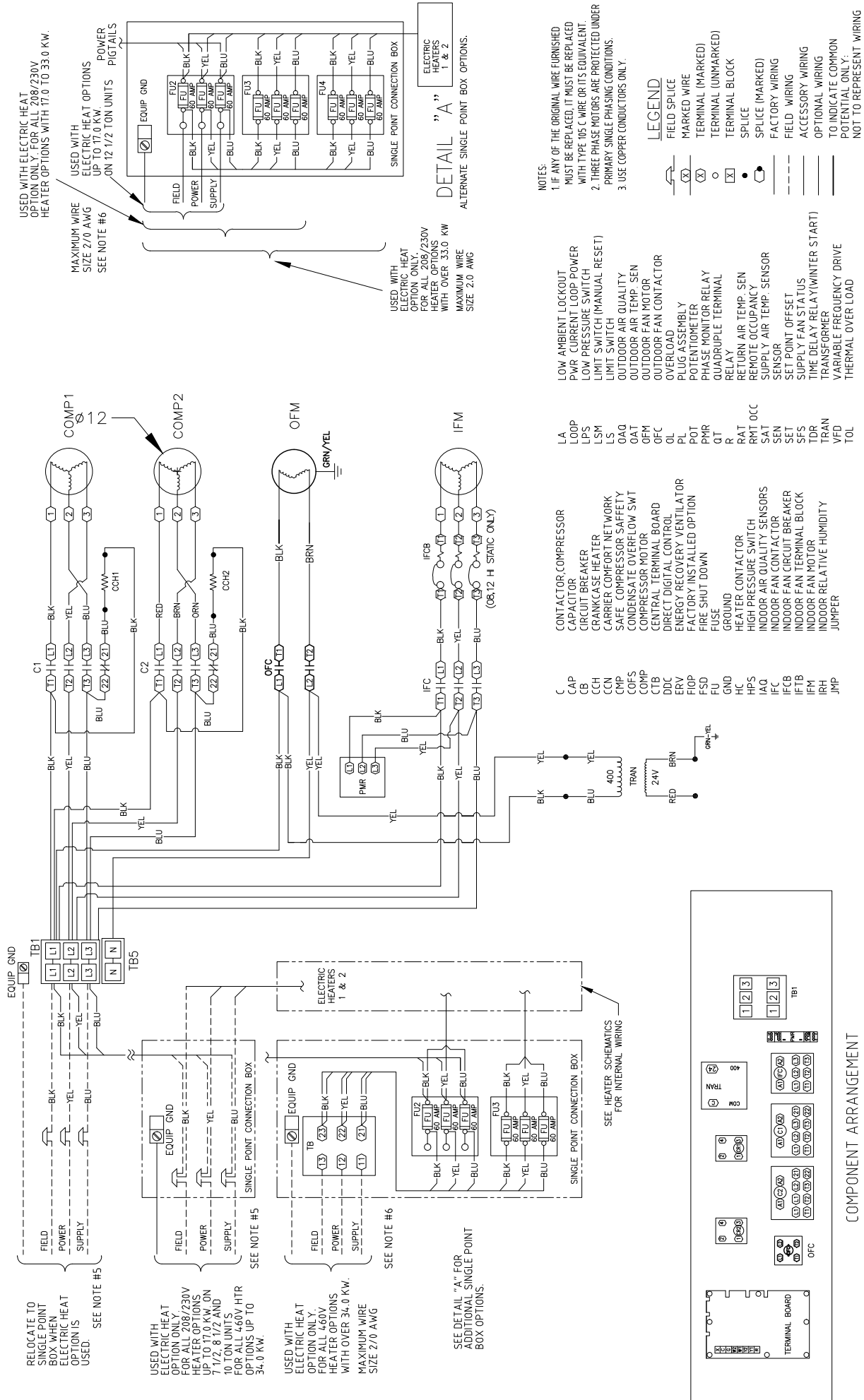

- CONTRACTOR/COMPRESSOR**
- LA LOOP
 - LPS
 - LSM
 - LS
 - OAG
 - OAT
 - OFM
 - OFC
 - OL
 - PL
 - POT
 - PMR
 - QT
 - R
 - RAT
 - RMT OCC
 - SAT
 - SEN
 - SET
 - SFS
 - TIME DELAY RELAY (WINTER START)
 - TDR
 - TRAN
 - VFD
 - TOL
- CONTACTOR, COMPRESSOR**
- CAP
 - CB
 - CCH
 - CCN
 - CMP
 - COFS
 - COMP
 - CTB
 - DDC
 - ERV
 - FISD
 - FU
 - GND
 - HC
 - HPS
 - IAC
 - IFC
 - IFCB
 - IFM
 - IRH
 - JMP
- CONTRACTOR, COMPRESSOR**
- LA LOOP
 - LPS
 - LSM
 - LS
 - OAG
 - OAT
 - OFM
 - OFC
 - OL
 - PL
 - POT
 - PMR
 - QT
 - R
 - RAT
 - RMT OCC
 - SAT
 - SEN
 - SET
 - SFS
 - TIME DELAY RELAY (WINTER START)
 - TDR
 - TRAN
 - VFD
 - TOL
- CONTRACTOR, COMPRESSOR**
- LA LOOP
 - LPS
 - LSM
 - LS
 - OAG
 - OAT
 - OFM
 - OFC
 - OL
 - PL
 - POT
 - PMR
 - QT
 - R
 - RAT
 - RMT OCC
 - SAT
 - SEN
 - SET
 - SFS
 - TIME DELAY RELAY (WINTER START)
 - TDR
 - TRAN
 - VFD
 - TOL

Typical Control Schematic - Series A - 50TCMA07

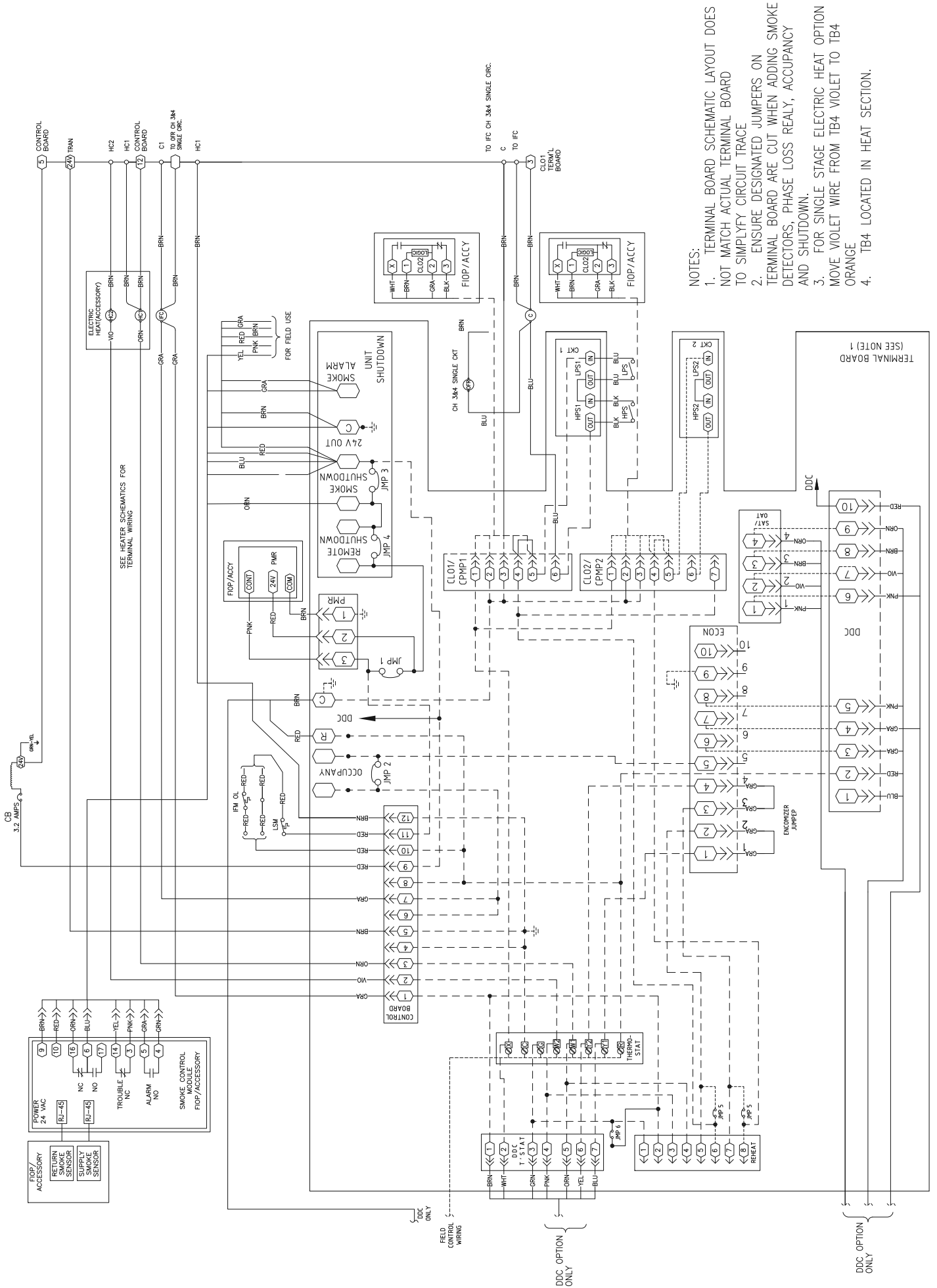

- NOTES:
1. TERMINAL BOARD SCHEMATIC LAYOUT DOES NOT MATCH ACTUAL TERMINAL BOARD TO SIMPLIFY CIRCUIT TRACE
 2. ENSURE DESIGNATED JUMPERS ON TERMINAL BOARD ARE CUT WHEN ADDING SMOKE DETECTORS; PHASE LOSS REALY, OCCUPANCY AND SHUTDOWN.
 3. FOR SINGLE STAGE ELECTRIC HEAT OPTION MOVE VIOLET WIRE FROM TB4 VIOLET TO TB4 ORANGE
 4. TB4 LOCATED IN HEAT SECTION.

Typical Control Schematic - Series A - 50TCMD08/09/12/13

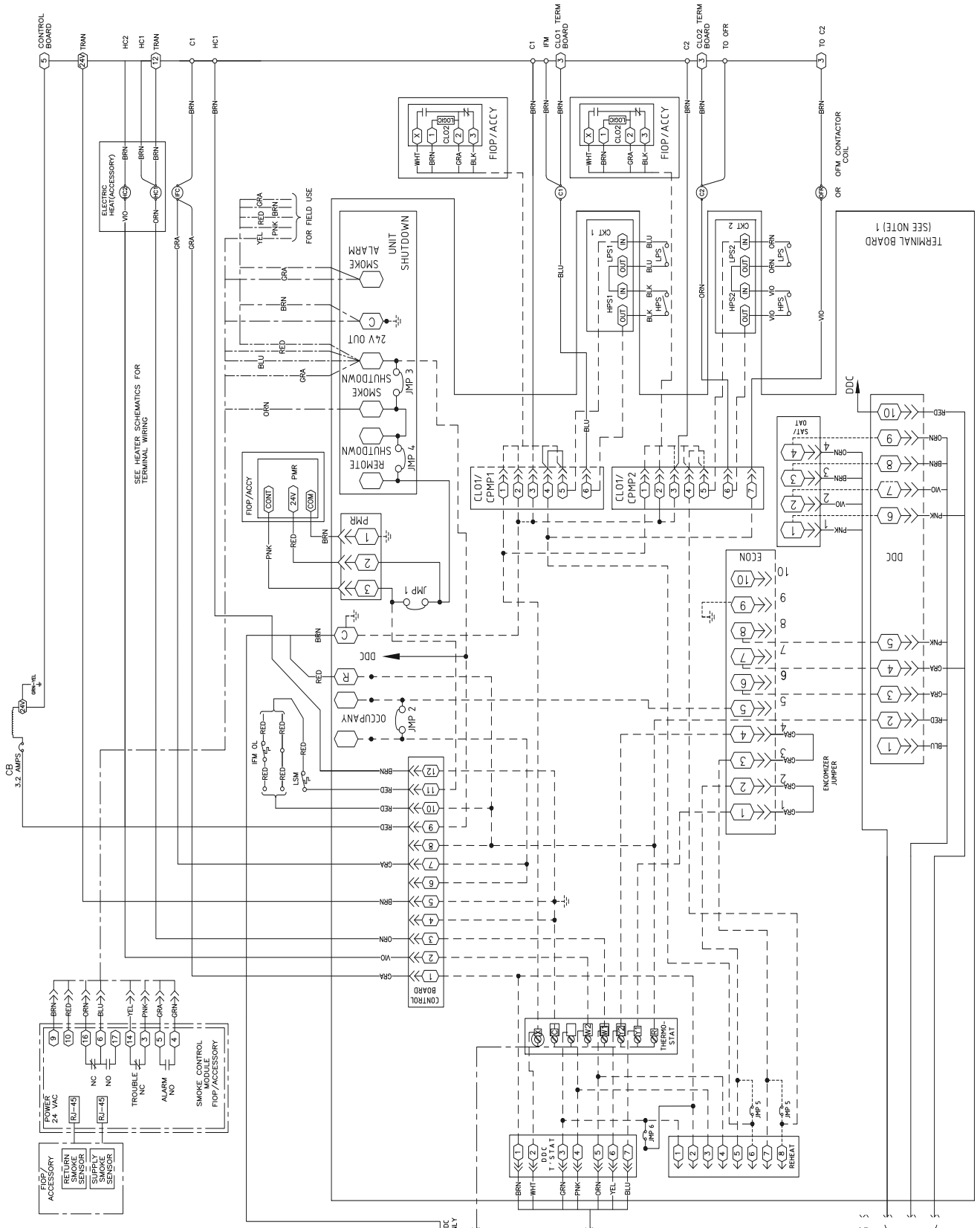

NOTES:

1. TERMINAL BOARD SCHEMATIC LAYOUT DOES NOT MATCH ACTUAL TERMINAL BOARD TO SIMPLIFY CIRCUIT TRACE
2. ENSURE DESIGNATED JUMPERS ON TERMINAL BOARD ARE CUT WHEN ADDING SMOKE DETECTORS, PHASE LOSS REPLY, OCCUPANCY AND SHUTDOWN.
3. FOR SINGLE STAGE ELECTRIC HEAT OPTION MOVE VIOLET WIRE FROM TB4 VIOLET TO TB4 ORANGE
4. TB4 LOCATED IN HEAT SECTION.

Typical Wiring Schematic - Series B - 50TCMA07

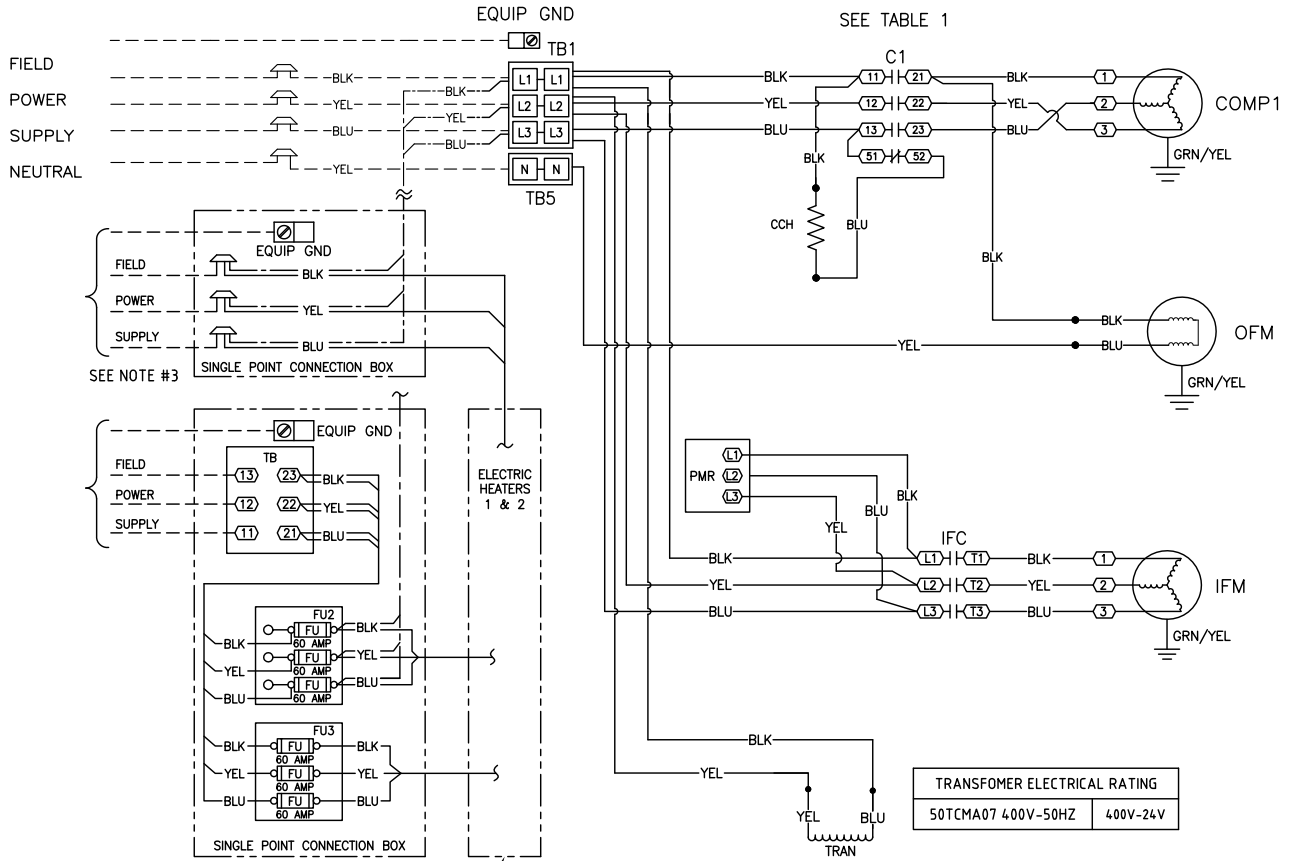

TRANSFORMER ELECTRICAL RATING	
50TCMA07 400V-50HZ	400V-24V

NOTES:

1. IF ANY OF THE ORIGINAL WIRE FURNISHED MUST BE REPLACED, IT MUST BE REPLACED WITH TYPE 105° C WIRE OR ITS EQUIVALENT.
2. THREE PHASE MOTORS ARE PROTECTED UNDERPRIMARY SINGLE PHASING CONDITIONS.
3. USE COPPER CONDUCTORS ONLY.
4. IFM WITHOUT OVERLOAD CONNECT RED WIRE TOGETHER

LEGEND

- FIELD SPLICE
- MARKED WIRE
- TERMINAL (MARKED)
- TERMINAL (UNMARKED)
- TERMINAL BLOCK
- SPLICE
- SPLICE (MARKED)
- FACTORY WIRING
- FIELD WIRING
- ACCESSORY WIRING
- OPTIONAL WIRING
- TO INDICATE COMMON POTENTIAL ONLY:
- NOT TO REPRESENT WIRING

- C CONTACTOR, COMPRESSOR
- CB CIRCUIT BREAKER
- COMP COMPRESSOR MOTOR
- EQUIP EQUIPMENT
- GND GROUND
- HC HEATER CONTACTOR
- HPS HIGH PRESSURE SWITCH
- IFC INDOOR FAN CONTACTOR
- IFM INDOOR FAN MOTOR
- IFM/OL INDOOR FAN MOTOR OVER LOAD
- LPS LOW PRESSURE SWITCH
- LSM LIMIT SWITCH (MANUAL RESET)
- OFM OUTDOOR FAN MOTOR
- OFR OUTDOOR FAN RELAY
- PMR PHASE MONITOR RELAY
- TB TERMINAL BOARD
- TRAN TRANSFORMER

TABLE 1 TERMINAL CONFIGURATION OF C1	
400V-50HZ	400V-60HZ/ 230V-60HZ
C1 L1-T1	C1 T1-T1
L2-T2	T2-T2
L3-T3	T3-T3
T1-T2	T1-T2

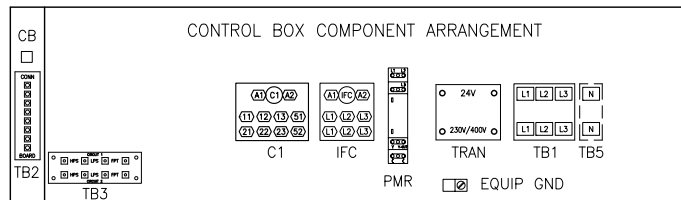

Typical Wiring Schematic - Series B - 50TCMD08

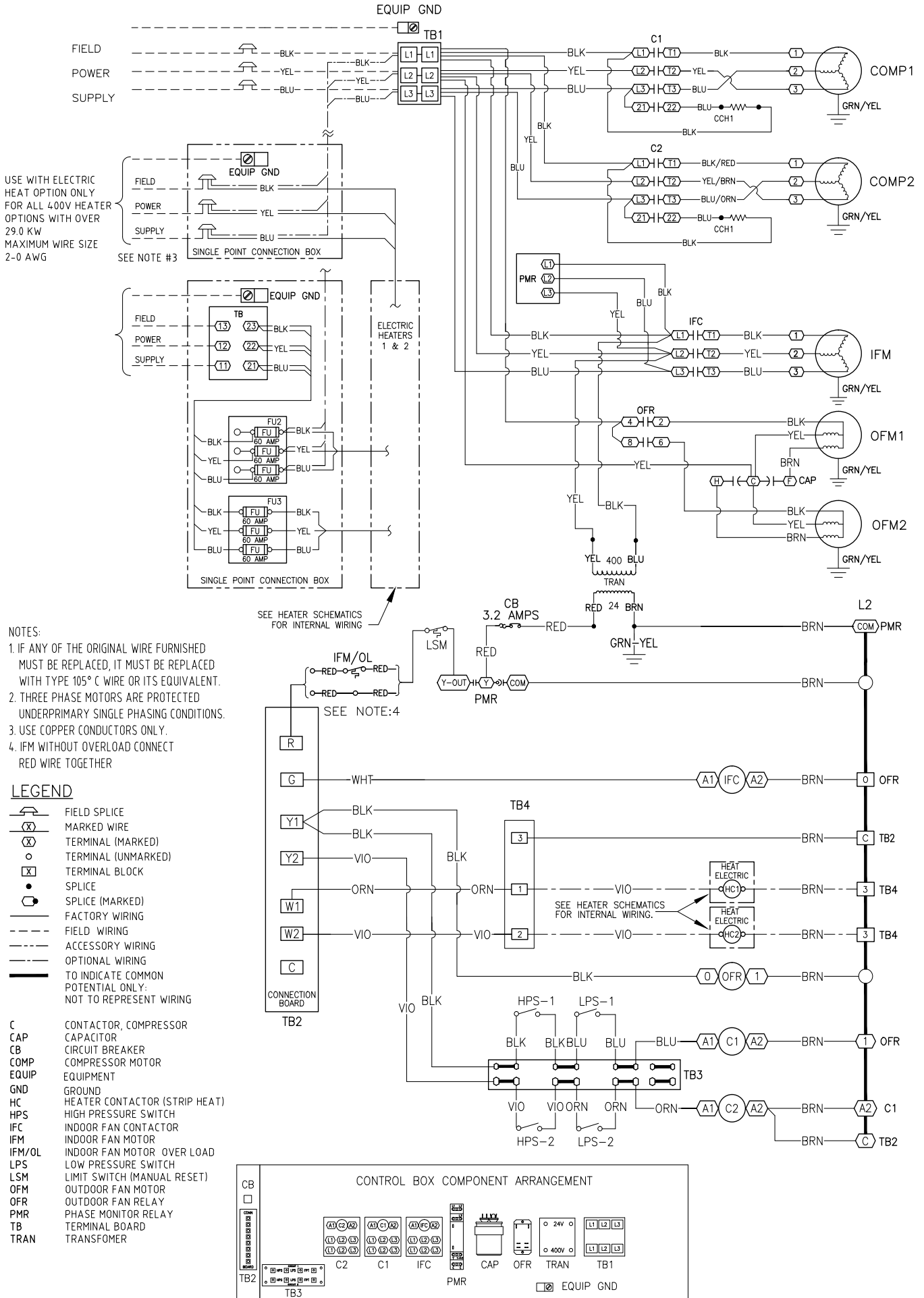

Typical Wiring Schematic - Series B - 50TCMD09/12

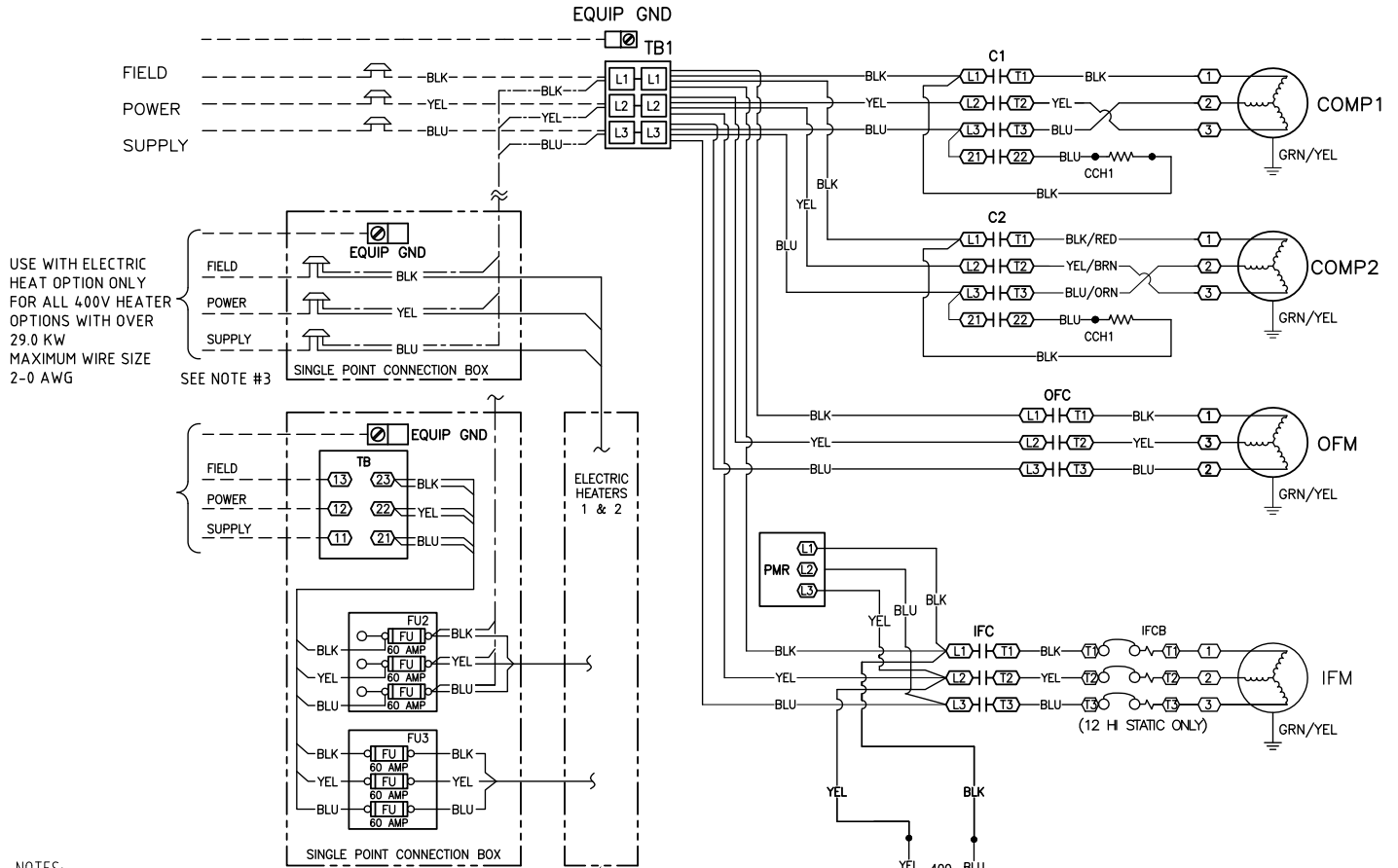

NOTES:

1. IF ANY OF THE ORIGINAL WIRE FURNISHED MUST BE REPLACED, IT MUST BE REPLACED WITH TYPE 105° C WIRE OR ITS EQUIVALENT.
2. THREE PHASE MOTORS ARE PROTECTED UNDERPRIMARY SINGLE PHASING CONDITIONS.
3. USE COPPER CONDUCTORS ONLY.
4. IFM WITHOUT OVERLOAD CONNECT RED WIRE TOGETHER
5. TOL CONNECTION ONLY FOR MOTOR HAVING EXTERNAL THERMAL OVER LOAD CONNECTION

LEGEND

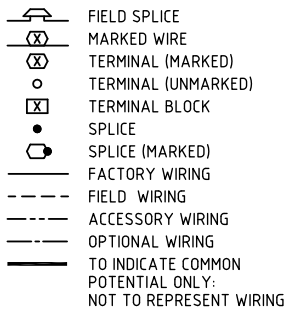

C	CONTACTOR, COMPRESSOR
CAP	CAPACITOR
CB	CIRCUIT BREAKER
COMP	COMPRESSOR MOTOR
EQUIP	EQUIPMENT
GND	GROUND
HC	HEATER CONTACTOR (STRIP HEAT)
HPS	HIGH PRESSURE SWITCH
IFC	INDOOR FAN CONTACTOR
IFM	INDOOR FAN MOTOR
IFCB	INDOOR FAN CIRCUIT BREAKER
IFM/OL	INDOOR FAN MOTOR OVER LOAD
IFR	INDOOR FAN RELAY
LPS	LOW PRESSURE SWITCH
LSM	LIMIT SWITCH (MANUAL RESET)
OFM	OUTDOOR FAN MOTOR
OFC	OUTDOOR FAN RELAY
PMR	PHASE MONITOR RELAY
TB	TERMINAL BOARD
TOL	THERMAL OVER LOAD
TRAN	TRANSFORMER

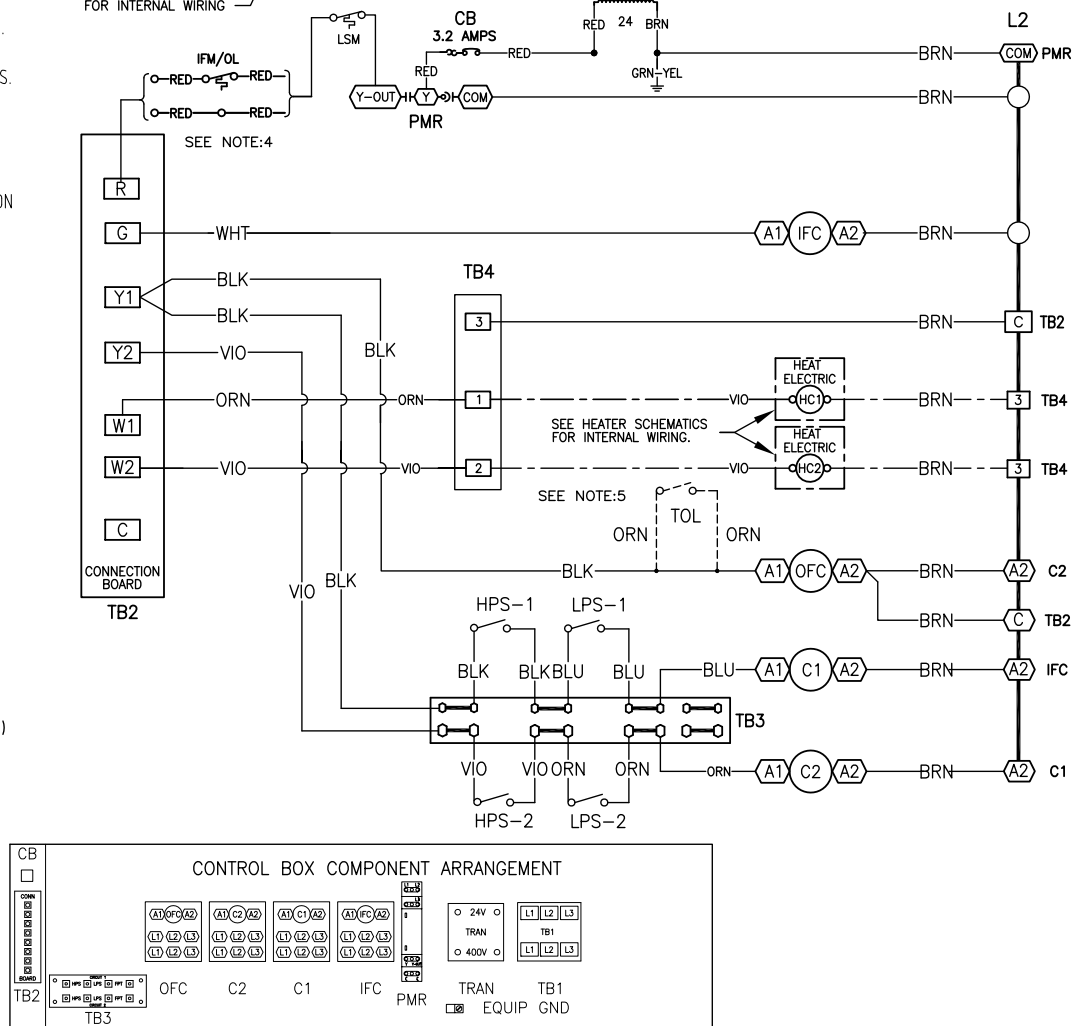

Typical Wiring Schematic - Series B - 50TCMD13

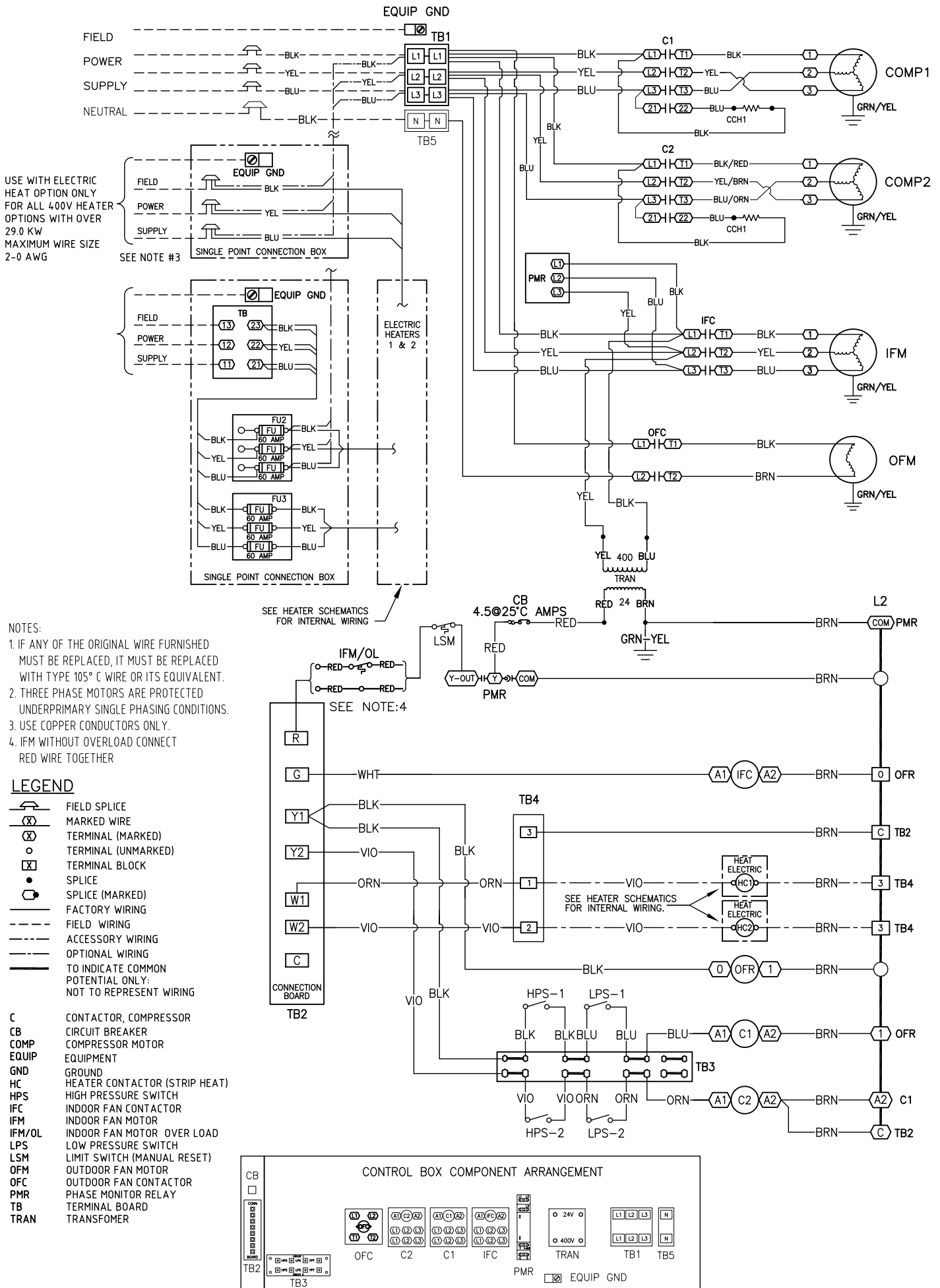

APPLICATION DATA

Min operating ambient temp (cooling)

In mechanical cooling mode, your Carrier rooftop can safely operate down to an outdoor ambient temperature of 40°F (4°C) and 25°F (- 4°C), with an accessory winter start kit.

Max operating ambient temp (cooling)

The maximum operating ambient temperature for cooling mode is 125°F (52°C).

Airflow

All units are draw-through in cooling mode.

Motor limits; Brake horsepower (BHP)

Due to Carrier's internal unit design, air path, and specially designed motors, the full horsepower (maximum continuous BHP) band, can be used with the utmost confidence. There is no need for extra safety factors, as Carrier's motors are designed and rigorously tested to use the entire, listed BHP range without either nuisance tripping or premature motor failure.

Sizing a rooftop

Bigger isn't necessarily better. While an air conditioner needs to have enough capacity to meet the load, it doesn't need excess capacity. In fact, having excess capacity typically results in very poor part load performance and humidity control.

Using higher design temperatures than ASHRAE recommends for your location, adding "safety factors" to the calculated load, and rounding up to the next largest unit, are all signs of oversizing air conditioners. Oversizing can cause short-cycling, and short cycling leads to poor humidity control, reduced efficiency, higher utility bills, drastic indoor temperature swings, excessive noise, and increased wear and tear on the air conditioner.

Rather than oversizing an air conditioner, wise contractors and engineers "right-size" or even slightly undersize air conditioners. Correctly sizing an air conditioner controls humidity better; promotes efficiency; reduces utility bills; extends equipment life, and maintains even, comfortable temperatures.

Winter start

Carrier's winter start kit extends the low ambient limit of your rooftop to 25°F (- 4°C). The kit bypasses the low pressure switch, preventing nuisance tripping of the low pressure switch. Other low ambient precautions may still be prudent.

GUIDE SPECIFICATIONS - 50TCM

Cooling Only/Electric Heat Packaged Rooftop HVAC Guide Specifications Size Range: 6.0 to 11.0 Nominal Tons



System Description

Small-Capacity Self-Contained Air Conditioners (50TCM)

Outdoor, rooftop mounted, electrically controlled, heating and cooling unit utilizing hermetic scroll compressor(s) for cooling duty and electric for heating duty.

Quality Assurance

1. Unit shall be designed to conform to ASHRAE 15, 2001.
2. Unit shall be rated in accordance with AHRI Standards 340/360.
3. Insulation and adhesive shall meet NFPA 90A requirements for flame spread and smoke generation.
4. Unit casing shall be capable of withstanding 500-hour salt spray exposure per ASTM B117 (scribed specimen).
5. Unit shall be designed in accordance with ISO 9001:2015 and shall be manufactured in a registered ISO 9001:2015 facility.
6. Unit shall be subjected to a completely automated run test on the assembly line. The data for each unit will be stored at the factory and must be available upon request.
7. Unit shall be designed in accordance with UL Standard 1995, including tested to withstand rain.

Delivery, Storage, and Handling

1. Unit shall be stored and handled per manufacturer's recommendations.
2. Lifted by crane requires either shipping top panel or spreader bars.
3. Unit shall only be stored or positioned in the upright position.

Product General

1. Factory assembled, single-piece heating and cooling rooftop unit. Contained within the unit enclosure shall be all factory wiring, piping, controls, and special features required prior to field start-up.
2. Unit shall use environmentally safe, Puron refrigerant.
3. Unit shall be installed in accordance with the manufacturer's instructions.
4. Unit must be selected and installed in compliance with local, state, and federal codes.
5. Interior cabinet surfaces shall be insulated with closed cell foam minimum ½ -in. thick, minimum density 3.1lb/ft³.

Unit Cabinet

1. Unit cabinet shall be constructed of galvanized steel, and shall be bonderized and coated with a pre-painted baked enamel finish on all externally exposed surfaces.
2. Unit cabinet exterior paint shall be: film thickness, (dry) 76mm minimum, gloss (per ASTM D523, 60°F): 60, Hardness: H-2H Pencil hardness.
3. Evaporator fan compartment interior cabinet insulation shall conform to AHRI Standards 210/240 or 340/360 minimum exterior sweat criteria.
4. Base of unit shall have a minimum of four locations for thru-the-base gas and electrical connections (factory installed or field installed), standard.
5. Base Rail
 - a) Unit shall have base rails on a minimum of 2 sides.
 - b) Holes shall be provided in the base rails for rigging shackles to ease maneuvering and overhead rigging.
 - c) Holes shall be provided in the base rail for moving the rooftop by fork truck.
 - d) Base rail shall be a minimum of 16 gauge thickness.
6. Condensate pan and connections:
 - a) Shall be a sloped condensate drain pan made of a non-corrosive material.
 - b) Shall comply with ASHRAE Standard 62.
 - c) Shall use a 3/4" - 14 NPT drain connection, possible either through the bottom or end of the drain pan. Connection shall be made per manufacturer's recommendations.
7. Top panel:

Shall be a single piece top panel on 07 size, two piece on 08 thru 13 size.
8. Electrical Connections:

All unit power wiring shall enter unit cabinet at a single, factory-prepared, knock out location.

9. Component access panels (standard):
 - a) Cabinet panels shall be easily removable for servicing.
 - b) Unit shall have one factory installed; tool-less, removable, filter access panel.
 - c) Panels covering control box, indoor fan, indoor fan motor, and compressors shall have molded composite handles.
 - d) Handles shall be UV modified, composite, permanently attached, and recessed into the panel.
 - e) Screws on the vertical portion of all removable access panels shall engage into heat resistant, molded composite collars.
 - f) Collars shall be removable and easily replaceable using manufacturer recommended parts.

Coils

Standard Aluminum fin-Copper Tube Coils:

1. Standard evaporator and condenser coils shall have aluminum lanced plate fins mechanically bonded to seam- less internally grooved copper tubes with all joints brazed.
2. Evaporator coils shall be leak tested to 150 psig, pressure tested to 450 psig, and qualified to UL 1995 burst test at 1775 psig.
3. Condenser coils shall be leak tested to 150 psig, pressure tested to 450 psig, and qualified to UL 1995 burst test at 1980 psig.

Optional Pre-coated aluminum-fin condenser coils:

1. Shall have a durable epoxy-phenolic coating to provide protection in mildly corrosive coastal environments.
2. Coating shall be applied to the aluminum fin stock prior to the fin stamping process to create an inert barrier between the aluminum fin and copper tube.
3. Epoxy-phenolic barrier shall minimize galvanic action between dissimilar metals.

Optional Copper-fin evaporator and condenser coils:

Shall be constructed of copper fins mechanically bonded to copper tubes

Refrigerant Components

1. Refrigerant circuit shall include the following control, safety, and maintenance features:
 - a) Refrigerant system shall include fixed orifice (size 09 to 13) or TXV metering system (size 07 and 08).
 - b) Fixed orifice metering system shall prevent mal-distribution of two-phase refrigerant by including multiple fixed orifice devices in each refrigeration circuit. Each orifice is to be optimized to the coil circuit it serves.
 - c) Refrigerant filter drier.
 - d) Service gauge connections on suction and discharge lines.
2. There shall be gauge line access, covered cap:
 - a) The plug shall be easy to remove and replace.
 - b) When the plug is removed, the gauge access port shall enable maintenance personnel to route their pressure gauge lines.
 - c) This gauge access port shall facilitate correct and accurate condenser pressure readings by enabling the reading with the compressor access panel on.
 - d) The plug shall be made of a leak proof, UV-resistant, composite material.
3. Compressors:
 - a) Unit shall use one fully hermetic, scroll compressor for each independent refrigeration circuit.
 - b) Compressor motors shall be cooled by refrigerant gas passing through motor windings.
 - c) Compressors shall be internally protected from high discharge temperature conditions.
 - d) Compressors shall be protected from an over-temperature and over-ampereage conditions by an internal, motor overload device.
 - e) Compressor shall be factory mounted on rubber grommets.
 - f) Compressor motors shall have internal line break thermal, current overload and high pressure differential protection.
 - g) Crankcase heaters shall not be required for normal operating range, unless provided by compressor manufacturer due to refrigerant charge limits.

Evaporator Fan and Motor

Evaporator Fan Motor:

1. Shall have permanently lubricated bearings.
2. Shall have inherent automatic-reset thermal overload protection.
3. Shall have a maximum continuous bhp rating for continuous duty operation; no safety factors above that rating shall be required.

Belt-driven Evaporator Fan:

1. Belt drive shall include an adjustable pitch motor pulley.
2. Shall use sealed, permanently lubricated ball-bearing type.
3. Blower fan shall be double-inlet type with forward-curved blades.
4. Shall be constructed from steel with a corrosion resistant finish and dynamically balanced.

Condenser Fans and Motors

Condenser Fan Motors:

1. Shall be a totally enclosed motor.
2. Shall use permanently lubricated bearings.
3. Shall have inherent thermal overload protection with an automatic reset feature.
4. Shall use a shaft-down design on 07 to 09 models and shaft-up design on 12/13 size with rain shield.

Condenser Fans:

1. Shall be a direct-driven propeller type fan.
2. Shall have aluminum blades riveted to corrosion-resistant steel spiders and shall be dynamically balanced.

Electric and Electronic Control System for HVAC

General:

1. Shall be complete with self-contained low-voltage control circuit protected by a resettable circuit breaker on the 24V transformer side. Transformer shall have 75VA capability.
2. Shall utilize color-coded wiring.
3. Unit shall include a minimum of one 8-pin screw terminal connection board for connection of control wiring.

Safeties:

1. Compressor over-temperature, over current.
2. Low pressure switch:
 - a. Units with 2 compressors shall have different sized connectors for the circuit 1 and circuit 2 low and high pressure switches. They shall physically prevent the cross wiring of the safety switches between circuits 1 and 2.
 - b. Low pressure switch shall use different color wire than the high pressure switch. The purpose is to assist the installer and service technician to correctly wire and or troubleshoot the rooftop unit.
3. High pressure switch:
 - a. Units with 2 compressors shall have different sized connectors for the circuit 1 and circuit 2 low and high pressure switches. They shall physically prevent the cross wiring of the safety switches between circuits 1 and 2.
 - b. High pressure switch shall use different color wire than the low pressure switch. The purpose is to assist the installer and service technician to correctly wire and or troubleshoot the rooftop unit.
4. Automatic reset, motor thermal overload protector.

Filter Section

1. Filters access is specified in the unit cabinet section of this specification.
2. Filters shall be held in place by a pivoting filter tray, facilitating easy removal and installation.
3. Shall consist of factory-installed, low velocity, throw-away 2 -in. thick fiberglass filters.
4. Filters shall be standard, commercially available sizes.
5. Only one size filter per unit is allowed.

Operating Characteristics

1. Unit shall be capable of starting and running at 125°F (52°C) ambient outdoor temperature, meeting maximum load criteria of AHRI Standard 210/240 or 340/360 at ± 10% voltage.
2. Compressor with standard controls shall be capable of operation down to 40°F (4°C), ambient outdoor temperatures. Accessory winter start kit is necessary if mechanically cooling at ambient temperatures down to 25°F (- 4°C).
3. Unit shall discharge supply air horizontally as shown on contract drawings.
4. Unit shall be factory configured for horizontal supply and return configurations.

Thermostats

Thermostat must:

1. Energize both "W" and "G" when calling for heat.
2. Have capability to energize 2 different stages of cooling, and 2 different stages of heating.
3. Include capability for occupancy scheduling.

Electrical Requirements

Main power supply voltage, phase, and frequency must match those required by the manufacturer.

Special Features: Options and Accessories

Open protocol, direct digital controller:

1. Shall be ASHRAE 62-2001 compliant.
2. Shall accept 18-30VAC, 50-60Hz, and consumer 15VA or less power.
3. Shall have an operating temperature range from - 40°F (- 40°C) to 130°F (54°C), 10% - 90% RH (non-condensing).
4. Shall include built-in protocol for BACNET (MS/TP and PTP modes), Modbus (RTU and ASCII), Johnson N2 and LonWorks. LonWorks Echelon processor required for all Lon applications shall be contained in separate communication board.
5. Shall allow access of up to 62 network variables (SNVT). Shall be compatible with all open controllers
6. Baud rate Controller shall be selectable using a dipswitch.
7. Shall have an LED display independently showing the status of serial communication, running, errors, power, all digital outputs, and all analog inputs.
8. Shall accept the following inputs: space temperature, set point adjustment, outdoor air temperature, indoor air quality, outdoor air quality, compressor lock-out, fire shutdown, enthalpy switch, and fan status/filter status/ humidity/ remote occupancy.
9. Shall provide the following outputs: Fan, cooling stage 1, cooling stage 2, heat stage 1, heat stage 2, heat stage 3/ exhaust.
10. Shall have built-in surge protection circuitry through solid state polyswitches. Polyswitches shall be used on in-coming power and network connections. Polyswitches will return to normal when the "trip" condition clears.
11. Shall have a battery backup capable of a minimum of 10,000 hours of data and time clock retention during power outages.
12. Shall have built- in support for Carrier technician tool.
13. Shall include an EIA-485 protocol communication port, an access port for connection of either a computer or a Carrier technician tool, an EIA-485 port for network communication to intelligent space sensors and displays, and a port to connect an optional LonWorks communications card.
14. Software upgrades will be accomplished by either local or remote download. No software upgrades through chip replacements are allowed.

Manual damper:

Manual damper package shall consist of damper, air inlet screen, and rain hood which can be preset to admit up to 50% outdoor air for year round ventilation.

Head Pressure Control Package:

1. Controller shall control coil head pressure by condenser-fan speed modulation or condenser-fan cycling and wind baffles.
2. Shall consist of solid-state control and condenser-coil temperature sensor to maintain condensing temperature between 90°F (32°C) and 110°F (43°C) at outdoor ambient temperatures down to -20°F (-29°C).

High/Medium-Static Indoor Fan Motor(s) and Drive(s):

Shall be factory-installed to provide additional performance range.

Smoke detectors:

1. Shall be a Four-Wire Controller and Detector.
2. Shall be environmental compensated with differential sensing for reliable, stable, and drift-free sensitivity.
3. Shall use magnet-activated test/reset sensor switches.
4. Shall have tool-less connection terminal access.
5. Shall have a recessed momentary switch for testing and resetting the detector.
6. Controller shall include:
 - a) One set of normally open alarm initiation contacts for connection to an initiating device circuit on a fire alarm control panel.
 - b) Two Form-C auxiliary alarm relays for interface with rooftop unit or other equipment.
 - c) One Form-C supervision (trouble) relay to control the operation of the Trouble LED on a remote test/reset station.
 - d) Capable of direct connection to two individual detector modules.
 - e) Can be wired to up to 12 other duct smoke detectors for multiple fan shutdown applications.

Winter start kit:

1. Shall contain a bypass device around the low pressure switch.
2. Shall be required when mechanical cooling is required down to 25°F (-4°C).

Time Guard:

1. Shall prevent compressor short-cycling by providing a 5-minute delay (± 2 minutes) before restarting a compressor after shutdown for any reason.
2. One device shall be required per compressor.

Electric Heat:

1. Heater element open coil resistance wire, nickel-chrome alloy, 0.29 inches inside diameter, strung through ceramic insulators mounted on metal frame. Coil ends are staked and welded to terminal screw slots.
2. Heater assemblies are provided with integral fusing for protection of internal heater circuits. Auto reset thermo limit controls, magnetic heater contactors (24V coil) and terminal block all mounted in electric heater control box (minimum 18 ga galvanized steel) attached to end of heater assembly.

NOTES

