



Quality Assurance
Certificate Reg. No:
04 100 950420



Subject to change without notice
Manufacturing point: Jeddah, Saudi Arabia
Nearest port of embarkation: Jeddah Islamic port
Product classification: Commercial

Installation, Operation and Maintenance

50TCM – 50Hz

**Nominal Cooling Capacity 6.0 – 11.0 Tons
HFC R-410A Refrigerant**

The 50TCM units are single side discharge rooftop cooling unit utilizing electric heat as an option. Units are pre-wired, pre-charged with R-410A refrigerant, and tested at the factory. These units can be placed on the side of a building or can be placed on a roof without roof curbs. Each unit is designed to occupy a minimal space. Piping and drain connections are readily accessible.

Contact your local Carrier representative for additional reference materials and information. www.carrier.com

Table of Contents

1.0 – SAFETY CONSIDERATIONS	3
1.1 – General	3
1.2 – Installation Safety Considerations	3
1.3 – Warranty	3
Unit Physical Data	5
Unit Dimensional Drawing	6
2.0 – INSTALLATION	12
2.1 – Jobsite Survey	12
2.2 – Plan for Unit Location	12
2.3 – Inspect Unit	12
2.4 – Rig and Place Unit	12
2.5 – Positioning and Clearance	13
2.6 – Field Fabricate Ductwork	14
2.7 – Make Unit Duct Connections	14
2.8 – Trap Condensate Drain	14
2.9 – Make Electrical Connections	14
3.0 – START-UP INSTRUCTIONS	16
3.1 – Unit Preparation	16
3.2 – Internal Wiring	16
3.3 – Compressor Mounting	16
3.4 – Refrigerant Service Ports	17
3.5 – Compressor Rotation	17
3.6 – Evaporator Fan	17
3.7 – Condenser Fans and Motors	17
3.8 – Return – Air Filters	17
3.9 – Base Unit Operation	17
4.0 – SERVICE	18
4.1 – Cleaning	18
4.2 – Lubrication	18
4.3 – Evaporator Fan Performance Adjustment	19
4.4 – Evaporator Fan Service and Replacement	19
4.5 – Belt Tension Adjustment	20
4.6 – Refrigerant Charge	20
4.7 – Protective Devices	20
4.8 – Control Circuit, 24 – V	20
5.0 – REPLACEMENT PARTS	20
Electrical Data	21
Typical Wiring Schematic	23
Fan Performance	33
Cooling Chart	36
R-410A Refrigerant Quick Reference Guide	40
Troubleshooting	41
Start-up Check List	42

SAFETY CONSIDERATIONS

General

Improper installation, adjustment, alteration, service, maintenance or use can cause explosion, fire, electrical shock or other conditions which may cause personal injury or property damage. Consult a qualified installer; service agency must use factory-authorized kits or accessories when modifying this product. Refer to the individual instructions packaged with the kits or accessories when installing.

The appliance is not to be used by persons (including children) with reduced physical, sensory or mental capabilities, or lack of experience and knowledge, unless they have been given supervision or instruction. Children should be supervised not to play with the appliance.

Follow all the safety codes. Wear safety glasses and work gloves. Use quenching cloths for brazing operations and have a fire extinguisher available. Read these instructions thoroughly and follow all warnings or cautions attached to the unit. Consult local building codes for special requirements. In absence of local codes, it is recommended that the USA standard ANSI/NFPA 70, National Electrical Code (NEC), be followed.

It is important to recognize safety information. This is the safety-alert symbol . When you see this symbol on the unit and in instructions or manuals, be alert to the potential for personal injury.

Understand the signal words DANGER, WARNING, CAUTION, and NOTE. These words are used with the safety-alert symbol. DANGER identifies the most serious hazards which **will** result in severe personal injury or death. WARNING signifies hazards which **could** result in personal injury or death. CAUTION is used to identify unsafe practices, which **may** result in minor personal injury or product and property damage. NOTE is used to highlight suggestions which **will** result in enhanced installation, reliability, or operation.

Installation Safety Considerations

After the unit has been received and when it is ready to be installed or reinstalled, it must be inspected for damage. If damage is detected upon receipt, immediately file a claim with the shipping company or repair. This machine must be installed in a location that is not accessible to the public and protected against access by non-authorized people. This machine must not be installed in an explosive atmosphere.

Do not remove the skid or the packaging until the unit is in its final position. The units can also be lifted with slings, using only the designated lifting points marked on the unit (labels on the chassis and a label with all unit handling instructions are attached to the unit). Use slings with the correct capacity, and always follow the lifting instructions on the certified drawings supplied for the unit.

Safety is only guaranteed, if these instructions are carefully followed. If this is not the case, there is a risk of material deterioration and injuries to personnel. These units are not designed to be lifted from above.

Warranty

Warranty is based on the general terms and conditions of the manufacturer. Any modifications to the design and/or installation made without discussion with Carrier and without advance written agreement will result in the loss of the right to any warranty claims and any claim for injury to personnel as a result of these modifications.



WARNING

ELECTRICALSHOCK HAZARD

Failure to follow this warning could cause personal injury, death and/or equipment damage.

Before performing service or maintenance operations on unit, always turn off main power switch to unit and install lockout tag.

Unit may have more than one power switch.



WARNING

UNIT OPERATION AND SAFETY HAZARD

Failure to follow this warning could cause personal injury, death and/or equipment damage.

Puron® (R-410A) refrigerant systems operate at higher pressures than standard R-22 systems. Do not use R-22 service equipment or components on Puron refrigerant equipment.



WARNING

PERSONAL INJURY AND ENVIRONMENTAL HAZARD

Failure to follow this warning could cause personal injury, death and/or equipment damage.

Relieve pressure and recover all refrigerant before system repair or final unit disposal.

Wear safety glasses and gloves when handling refrigerants. Keep torches and other ignition sources away from refrigerants and oils.



CAUTION

CUT HAZARD

Failure to follow this warning could cause personal injury.

Sheet metal parts may have sharp edges or burrs. Use care and wear appropriate protective clothing, safety glasses and gloves when handling parts and servicing furnaces.

Table - 1 Unit Physical Data (English)

Unit 50TCM	A07	D08	D09	D12	D13
Unit Dimensions - (in)	41.3x74.3x46.7	41.2x88.1x59.4	49.3x88.1x59.4		
Unit Operating Weight - (LBS)	606	761	865	904	1076
Refrigeration System					
Compressor No.# / Type	1 / Scroll		2 / Scroll		
Refrigerant type	Puron ® R410A				
Circuits No.#	1		2		
Charge per Circuit (1-Down/2-Up) - (LBS)	15.33	8.71/ 7.05	8.77/9.8	11.6/11.51	13.01/12.79
Metering Device	TXV		Acutrol		
Filter Drier Qty	1		2		
High Pressure Switch (Trip/ Reset) - (PSIG)	630 / 505				
Low Pressure Switch (Trip/ Reset) - (PSIG)	54 / 117				
Condenser Coil					
Coil Type	Helical Grooved Copper Tube, Aluminum DW fins.				
Standard Coil Material	Cu/Al				
Rows / FPI	2 / 17			3 / 17	
Face Area (ft ²)	21.3	20.5	25.1		
Coil test Pressure (PSIG)	450				
Condenser Fan & Motor					
Approx. Air Flow Rate (CFM)	5000	6400	7800	9200	
Quantity	1	2	1		
Diameter (in) / No. of Blades	26/3	22/3	30/4	30/3	
Motor Type	Totally Enclosed				
Motor HP - RPM	1/3 - 1430	1/3 - 1200	1-950	1 - 835	
Evaporator Coil					
Coil Type	3/8" Helical Grooved Copper Tube, 0.75" Aluminum LSW Fins.				
Standard Coil Material	Cu/Al				
Rows / FPI	4/15	4/15			
Face Area (ft ²)	7.3	8.9	11.1		
Coil test Pressure (PSIG)	350				
Drain Pan connection Size (in)	3/4				
Return Air Filter Qty/ Size (in)	4 / 16x16x2	4 / 16x20x2	4 / 20x20x2		
Evaporator Fan & Motor section					
Fan Quantity / Fan Size (in)	1 / 10 x 10		1 / 15 x 15		
Fan Type	Centrifugal - Forward Blade				
Drive Type	Belt				
Motor Type	Open Drip Proof				
Standard Static Drive					
Motor Qty	1				
Maximum BHP	1.4	2		2.4	
FLA	2.6			3.4	
Efficiency @ Full Load	80%			81%	
RPM Range	855 - 1211	570 - 808		665 - 903	
Shaft Diameter (in)	5/8			7/8	
Motor Frame Size	56Y				
Medium Static Drive					
Motor Qty	1				
Maximum BHP	2.4		3.1	3.9	
FLA	3.4		4.4	7.4	
Efficiency @ Full Load	81%				
RPM Range	1077 - 1449	692 - 932	808 - 1082	837 - 1056	
Shaft Diameter (in)	7/8				
Motor Frame Size	56Y		56HZ	145TY	

CURBS & WEIGHTS DIMENSIONS - 50TCM07

NOTES:

1. DIMENSIONS ARE IN INCHES, DIMENSIONS IN () ARE IN MILLIMETERS.
2. CENTER OF GRAVITY
3. DIRECTION OF AIR FLOW

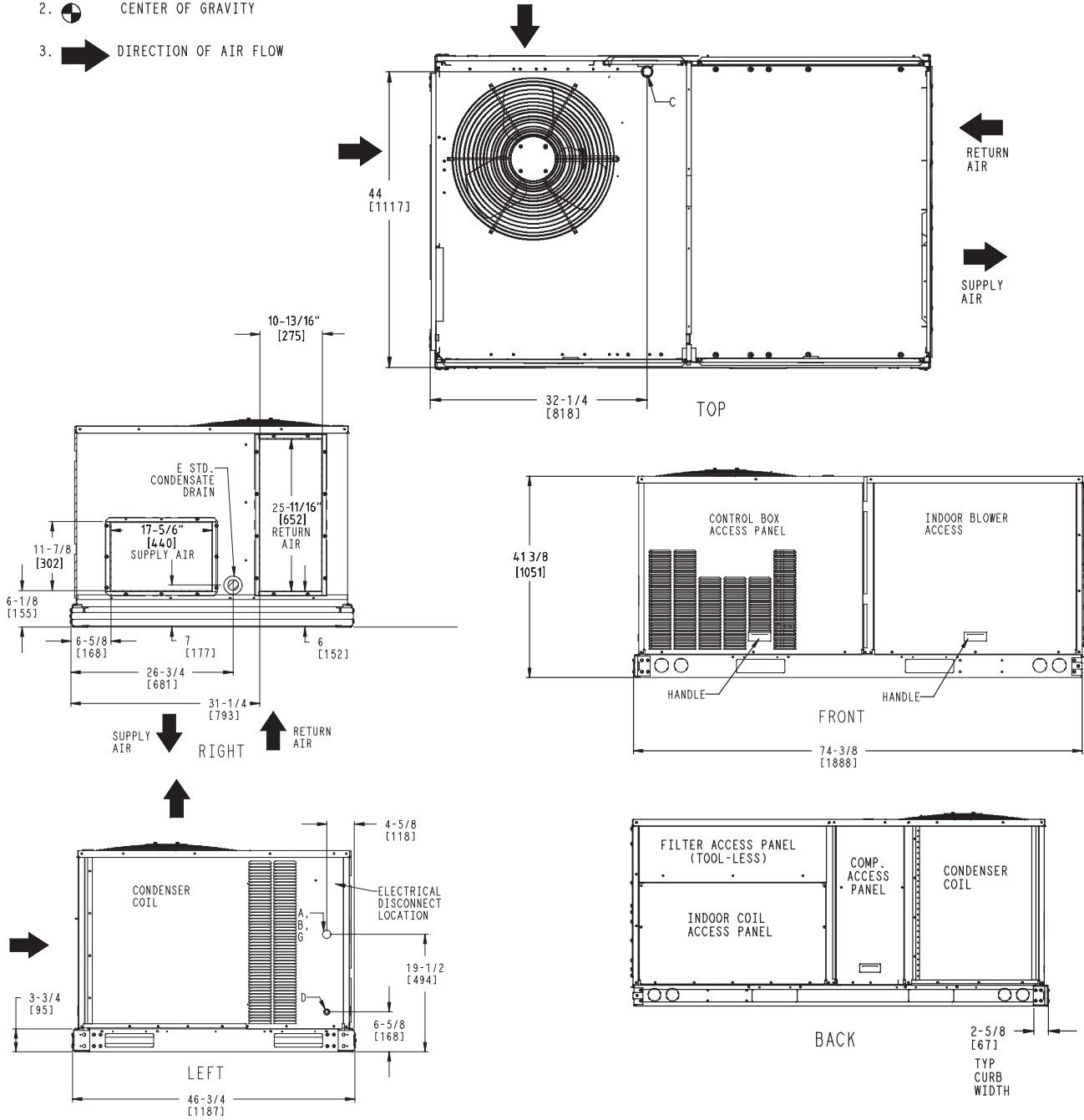

CONNECTION SIZES	
A	1 3/8" DIA [35] FIELD POWER SUPPLY HOLE
B	2" DIA [51] POWER SUPPLY KNOCKOUT
C	1 3/4" DIA [44] GAUGE ACCESS PLUG
D	7/8" DIA [22] FIELD CONTROL WIRING HOLE
E	3/4"-14 NPT CONDENSATE DRAIN
G	2 1/2" DIA [64] POWER SUPPLY KNOCK-OUT

Dimensions 50TCMA07

CURBS & WEIGHTS DIMENSIONS - 50TCM07 (cont.)

UNIT	STD. UNIT WEIGHT		CORNER WEIGHT (A)		CORNER WEIGHT (B)		CORNER WEIGHT (C)		CORNER WEIGHT (D)		C.G.		HEIGHT
	LBS.	KG.	LBS.	KG.	LBS.	KG.	LBS.	KG.	LBS.	KG.	X	Y	Z
50TCMA07	607	275	150	68	160	73	153	69	144	65	38 [965]	22 [559]	20 3/4 [527]

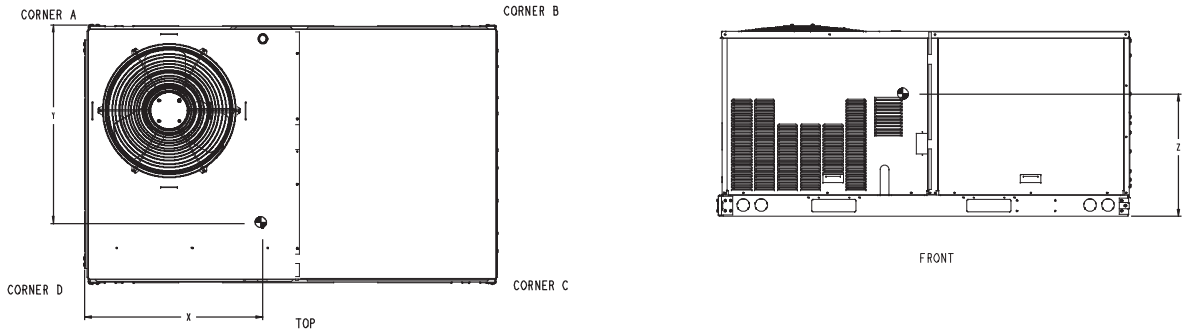

Dimensions 50TCMA07

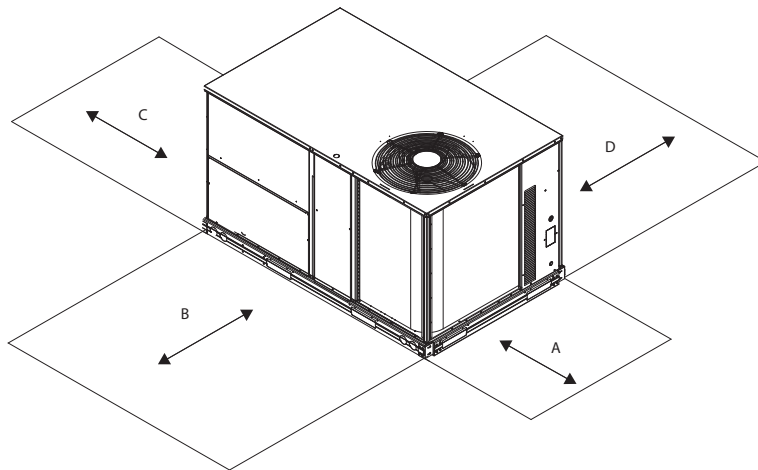

Service Clearance

LOC	DIMENSION	CONDITION
A	48-in (1219 mm) 18-in (457 mm) 18-in (457 mm) 12-in (305 mm)	Unit disconnect is mounted on panel No disconnect, convenience outlet option Recommended service clearance Minimum clearance
B	42-in (1067 mm) 36-in (914 mm)	Surface behind servicer is grounded (e.g., metal, masonry wall) Surface behind servicer is electrically non-conductive (e.g., wood, fiberglass)
C	36-in (914 mm) 18-in (457 mm)	Side condensate drain is used Minimum clearance
D	42-in (1067 mm) 36-in (914 mm)	Surface behind servicer is grounded (e.g., metal, masonry wall, another unit) Surface behind servicer is electrically non-conductive (e.g., wood, fiberglass)

CURBS & WEIGHTS DIMENSIONS - 50TCMD08

NOTES:

1. DIMENSIONS ARE IN INCHES, DIMENSIONS IN () ARE IN MILLIMETERS.
2. CENTER OF GRAVITY
3. DIRECTION OF AIR FLOW

CONNECTION SIZES	
A	1 3/8" DIA [35] FIELD POWER SUPPLY HOLE
B	2 1/2" [64] DIA POWER SUPPLY KNOCKOUT
C	1 3/4" DIA [51] GAUGE ACCESS PLUG
D	7/8" DIA [22] FIELD CONTROL WIRING HOLE
E	3/4"-14 NPT CONDENSATE DRAIN
G	2 " DIA [51] POWER SUPPLY KNOCK-OUT

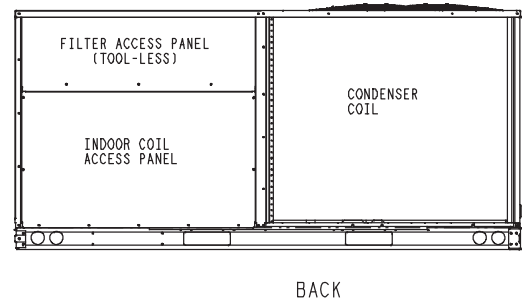
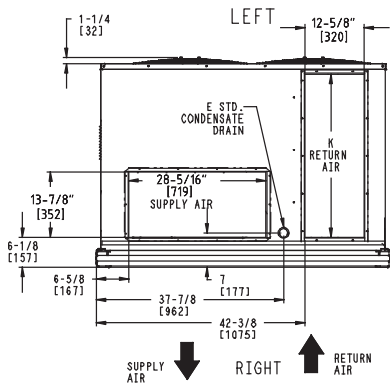
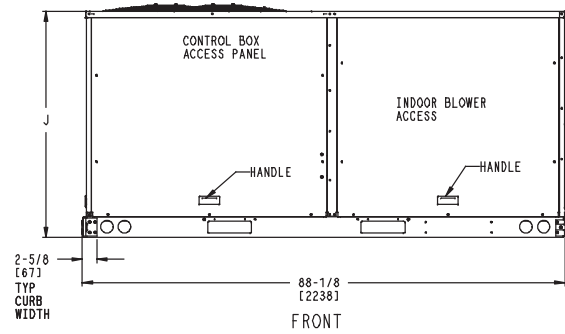
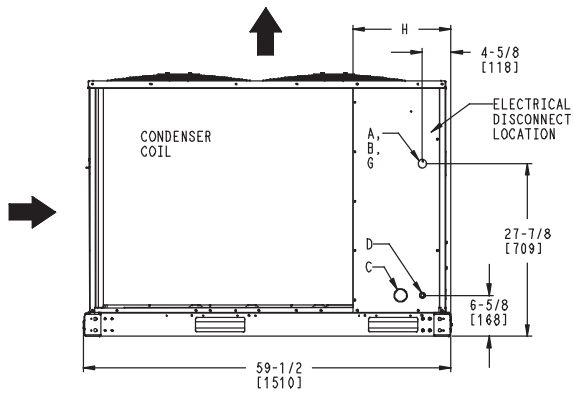
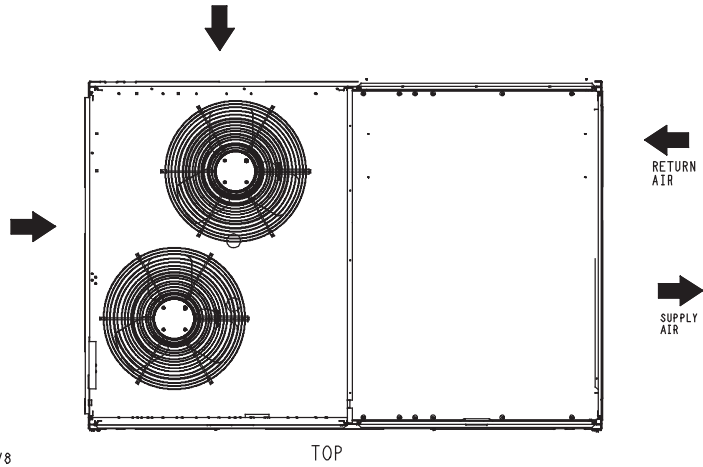

UNIT	OUTDOOR COIL TYPE	J	K	H
50TCMD08	RTPF	41 1/4 [1048]	33 11/16" [856]	15 7/8 [403]
RTPF - ROUND TUBE, PLATE FIN (COPPER/ALUM)				

Dimensions 50TCMD08

CURBS & WEIGHTS DIMENSIONS - 50TCMD08 (cont.)

UNIT	OUTDOOR COIL TYPE	STD. UNIT WEIGHT ***		CORNER WEIGHT (A)		CORNER WEIGHT (B)		CORNER WEIGHT (C)		CORNER WEIGHT (D)		C.G.		
		LBS.	KG.	LBS.	KG.	LBS.	KG.	LBS.	KG.	LBS.	KG.	X	Y	Z
50TCMD08	RTPF	760	345	158	71.7	155	70.4	222	100.8	225	102.2	43 3/4 [1111.3]	35 [889]	20 [508]
RTPF - ROUND TUBE, PLATE FIN (COPPER/ALUM)				*** STANDARD UNIT WEIGHT IS WITHOUT ELECTRIC HEAD AND PACKAGING FOR OTHER OPTIONS AND ACCESSORIES, REFER TO PRODUCT DATA CATALOG										

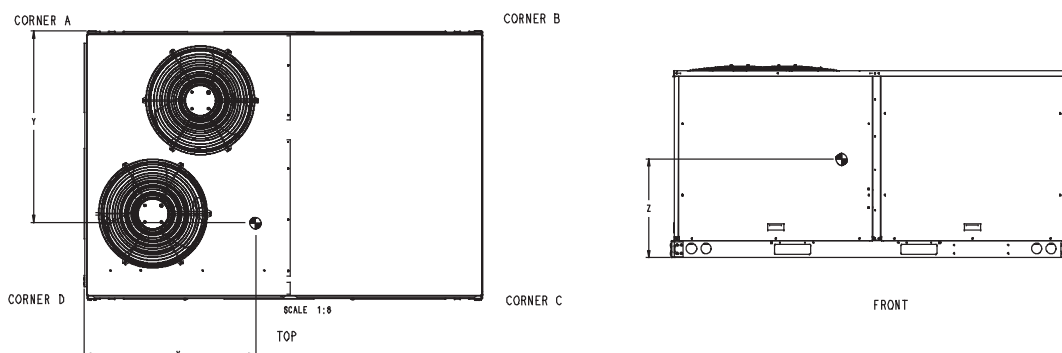

Dimensions 50TCMD08

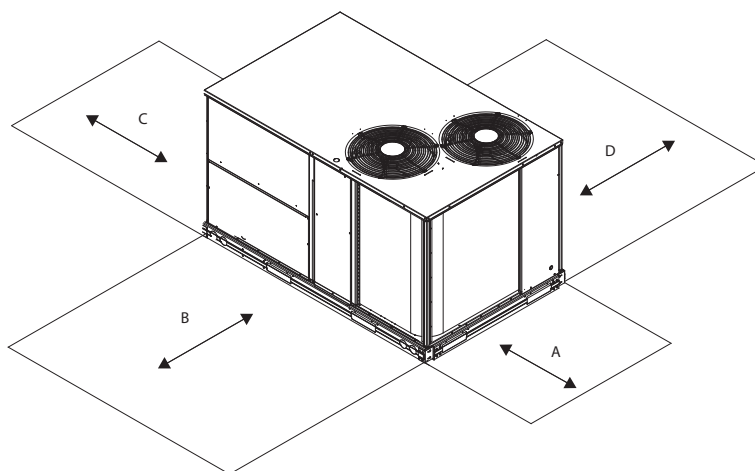

Service Clearance

LOC	DIMENSION	CONDITION
A	48-in (1219 mm)	Unit disconnect is mounted on panel
	36-in (914 mm)	If dimension-B is 12-in (305 mm)
	18-in (457 mm)	No disconnect, convenience outlet option
	18-in (457 mm)	Recommended service clearance (use electric screwdriver)
	12-in (305 mm)	Minimum clearance (use manual ratchet screwdriver)
B	12-in (305 mm)	If dimension-A is 36-in (914 mm)
	36-in (914 mm)	Side condensate drain is used
C	18-in (457 mm)	Minimum clearance
	42-in (1067 mm)	Surface behind servicer is grounded (e.g., metal, masonry wall, another unit)
D	36-in (914 mm)	Surface behind servicer is electrically non-conductive (e.g., wood, fiberglass)

CURBS & WEIGHTS DIMENSIONS - 50TCMD 09/12/13

NOTES:

1. DIMENSIONS ARE IN INCHES. DIMENSIONS IN () ARE IN MILLIMETERS.
2. CENTER OF GRAVITY
3. DIRECTION OF AIR FLOW

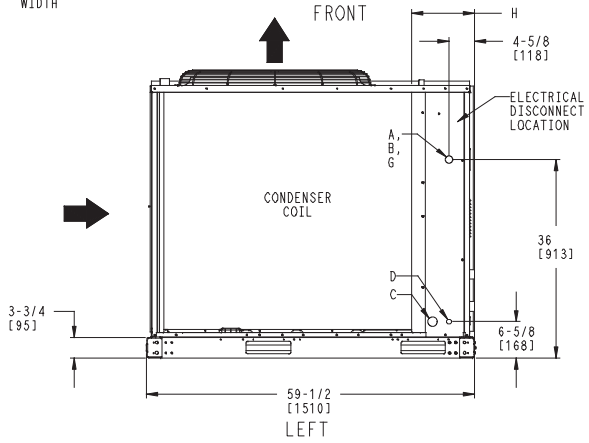
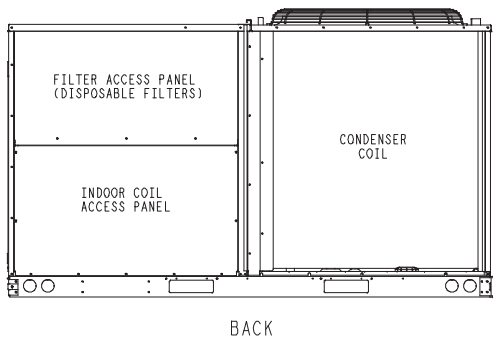
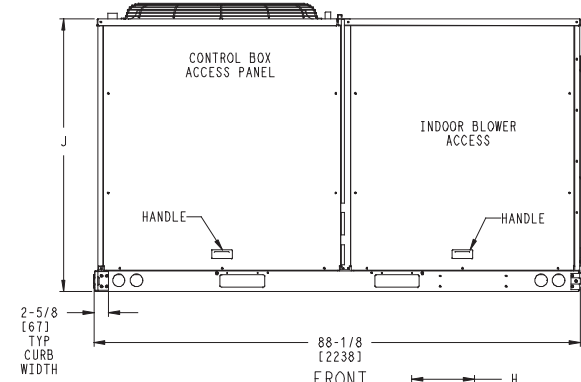
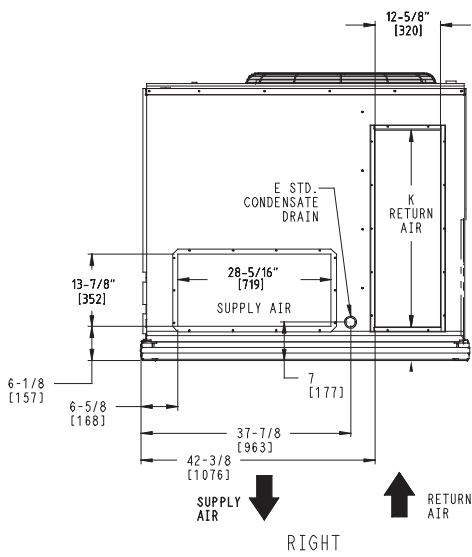
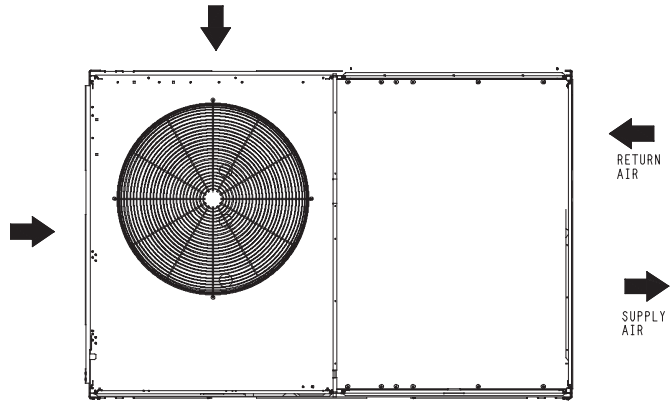

CONNECTION SIZES	
A	1 3/8" [35] DIA FIELD POWER SUPPLY HOLE
B	2 1/2" [64] DIA POWER SUPPLY KNOCKOUT
C	1 3/4" [51] DIA GAUGE ACCESS PLUG
D	7/8" [22] DIA FIELD CONTROL WIRING HOLE
E	3/4"-14 NPT CONDENSATE DRAIN
G	2" [51] DIA POWER SUPPLY KNOCK-OUT

UNIT	H	J	K
50TCMD09	11 3/8 [289]	49 3/8 [1253]	36 3/8" [924]
50TCMD12	11 3/8 [289]	49 3/8 [1253]	36 3/8" [924]
50TCMD13	11 3/8 [289]	49 3/8 [1253]	36 3/8" [924]

Dimensions 50TCMD 09/ 12 / 13

CURBS & WEIGHTS DIMENSIONS - 50TCMD 09/12/13 (cont.)

UNIT	OUTDOOR COIL TYPE	STD. UNIT WEIGHT ***		CORNER WEIGHT (A)		CORNER WEIGHT (B)		CORNER WEIGHT (C)		CORNER WEIGHT (D)		C.G.		
		LBS.	KG.	LBS.	KG.	LBS.	KG.	LBS.	KG.	LBS.	KG.	X	Y	Z
50TCMD09	RTPF	865	393	275	125	125	57	145	66	321	146	28 3/8 [721]	33 1/8 [841]	21 3/8 [543]
50TCMD12	RTPF	904	410	287	130	131	59	152	69	335	152	28 3/8 [721]	33 1/8 [841]	21 3/8 [543]
50TCMD13	RTPF	1076	489	341	155	156	71	180	82	398	181	28 3/8 [721]	33 1/8 [841]	21 3/8 [543]

*** STANDARD UNIT WEIGHT IS WITHOUT ELECTRIC HEAD AND PACKAGING
FOR OTHER OPTIONS AND ACCESSORIES, REFER TO PRODUCT DATA CATALOG

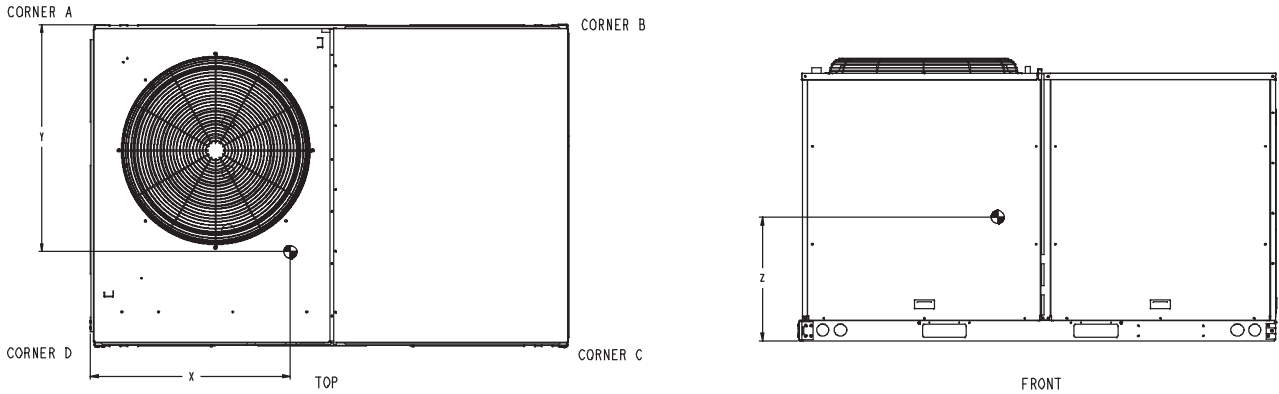

Dimensions 50TCMD 09/12/13

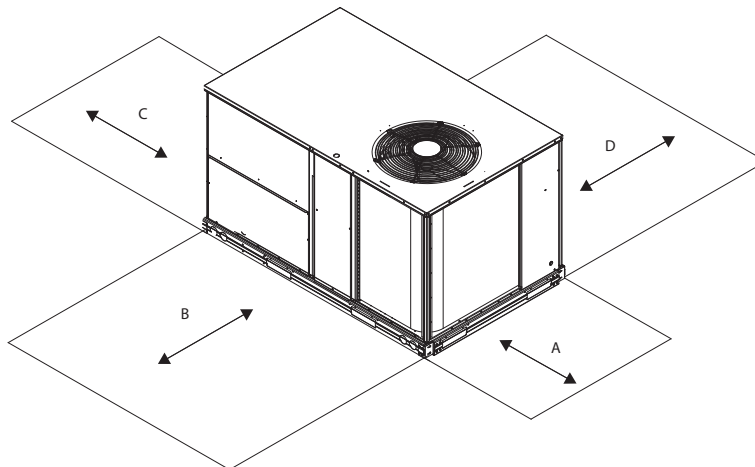

Service Clearance

LOC	DIMENSION	CONDITION
A	48-in (1219 mm)	Unit disconnect is mounted on panel
	18-in (457 mm)	No disconnect, convenience outlet option
	18-in (457 mm)	Recommended service clearance
	12-in (305 mm)	Minimum clearance
B	42-in (1067 mm)	Surface behind servicer is grounded (e.g., metal, masonry wall)
	36-in (914 mm)	Surface behind servicer is electrically non-conductive (e.g., wood, fiberglass)
C	36-in (914 mm)	Side condensate drain is used
	18-in (457 mm)	Minimum clearance
D	42-in (1067 mm)	Surface behind servicer is grounded (e.g., metal, masonry wall, another unit)
	36-in (914 mm)	Surface behind servicer is electrically non-conductive (e.g., wood, fiberglass)

2.0 – INSTALLATION

2.1 – Jobsite Survey

Complete the following checks before installation.

1. Consult local building codes or the U.S.A. National Electrical Code (Ref: ANSI/NFPA 70, [American National Standards Institute/National Fire Protection Association], latest revision) for special installation requirements.
2. Determine unit location (from project plans) or select unit location.
3. Check for possible overhead obstructions which may interfere with unit lifting or rigging.

2.2 – Plan for Unit Location

Select a location for the unit and its support system (curb or other) that provides for the minimum clearances required for safety. This includes the clearance to combustible surfaces, unit performance and service access below, around and above unit as specified in Fig - 1. For the centre of gravity coordinates, the position of the unit mounting holes, and the weight distribution points, refer to the Unit Dimensional Drawing.

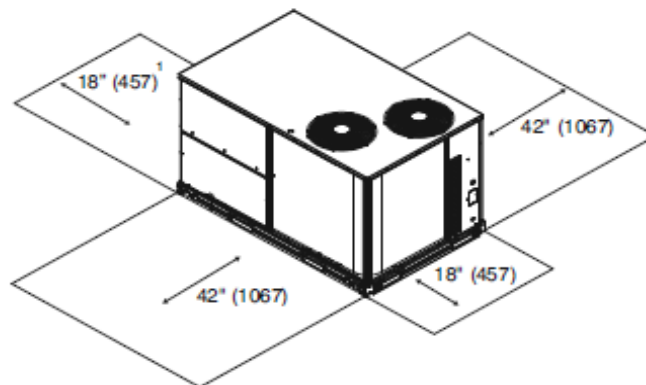

¹ Required bottom condensate drain connection.
Otherwise, 36" (914mm) for condensate connection.

Fig. 1 Unit Clearance Diagram

NOTES:

1. Consider also the effect of adjacent units.
2. Do not install unit in an indoor location.

2.3 – Inspect Unit

Inspect unit for transportation damage. File any claim with transportation agency. Confirm before installation of unit that voltage, amperage and circuit protection requirements listed on unit data plate agree with power supply provided.

2.4 – Rig and Place Unit

Keep unit upright and do not drop. Spreader bars are not required if top crating is left on unit.

Rollers may be used to move unit across a roof level by using unit frame as a reference; leveling tolerance is $\pm 1/16$ in. per linear ft in any direction.

Four lifting holes are provided in ends of unit base rails as shown in Fig – 2 Refer to rigging instructions on unit.

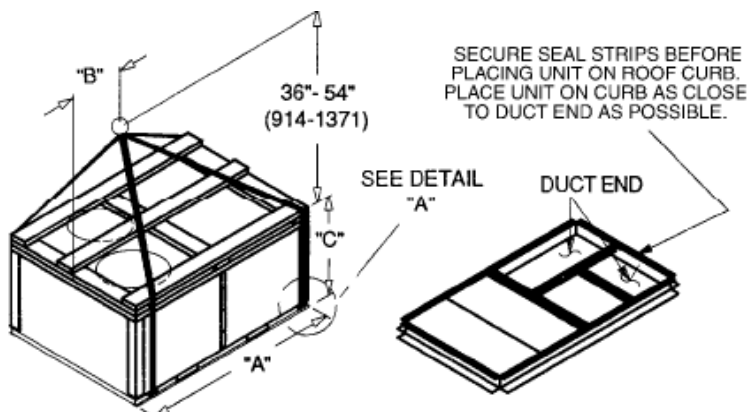

NOTES:

1. Dimension in () is in millimeters.
2. Hook rigging shackles through holes in base rail, as shown in detail "A." Holes in base rails are centered around the unit center of gravity. Use wooden top skid when rigging to prevent rigging straps from damaging unit.
3. Unit weights do not include economizer.

Fig. 2 Rigging Diagram

Roof mount - Check building codes for weight distribution requirements. Unit weight and dimensions is shown in unit dimensional drawing and Table 2.

UNIT	Max Weight		DIMENSIONS					
			A		B		C	
	LB	KG	IN	MM	IN	MM	IN	MM
50TCMA07	752	341	74.4	1888	38.0	965	41.4	1051
50TCMD08	911	413	88.0	2235	41.0	1040	41.5	1055
50TCMD09	1050	476	88.0	2235	40.5	1030	49.5	1255
50TCMD12	1058	480	88.0	2235	40.0	1015	49.5	1255
50TCMD13	1270	576	88.0	2235	28.5	725	53.0	1345

Table – 2 Unit Weights and Dimensions

NOTES:

1. Remove boards at ends of unit and runners prior to rigging.
2. Rig by inserting hooks into unit base rails as shown. Use bumper boards for spreader bars.

Crub should be level. This is necessary for unit drain to function properly. Unit leveling tolerances are shown in Fig.3

Fig. 3 Unit Leveling Tolerance



2.5 – Positioning and Clearance

Before positioning the unit, check the following:

- The permitted loading at the site is adequate or that appropriate strengthening measures have been taken.
- The unit is installed level on an even surface.
- Ensure access to the components (see “Unit Dimensional Drawings” & “Clearance Diagram” Fig 1).
- The number of support points is adequate and that they are in the right places.
- Although the unit is weatherproof guard against water from higher level runoff and overhangs.

Unit may be installed directly on wood flooring or on approved roof - covering material when roof curb is used. Do not install unit in an indoor location. Do not locate air inlets near exhaust vents or sources of contaminated air.

Curb should be level. This is necessary for unit drain to function properly. Unit leveling tolerances are shown in Fig.3

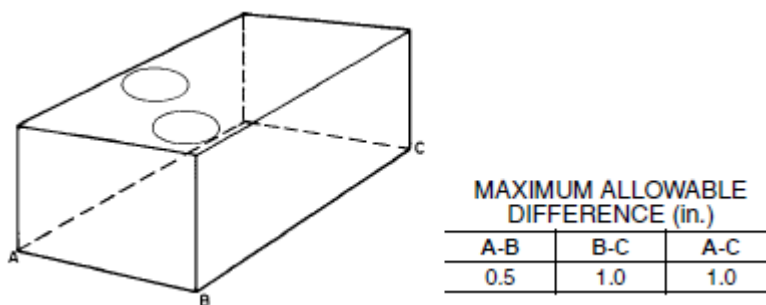

Fig. 3 Unit Leveling Tolerance

2.6 – Field Fabricate Ductwork

Secure all ducts to building structure. Use flexible duct connectors between unit and ducts as required (*a space for 2.5 to 3ft is required in case of repairing or replacing the blower wheel*). Insulate and weatherproof all external ductwork, joints, and roof openings with counter flashing and mastic in accordance with applicable codes. Ducts passing through an unconditioned space must be insulated and covered with a vapor barrier.

The 50TCM units with electric heat require a 2-in. clearance for the first 24-in. of ductwork. Outlet grilles must not lie directly below unit discharge.



NOTE

IMPORTANT

A 90-degree elbow must be provided in drain hole and must be removed in ductwork to comply with UL (Underwriters' Laboratories) codes for use with electric heat.

2.7 – Make Unit Duct Connections

Unit is shipped for side duct connections. Ductwork openings are shown in unit dimensional drawings.

2.8 – Trap Condensate Drain

The unit has one 3/4-in. condensate drain connection on the end of the condensate pan and an alternate connection on the bottom. See Fig. 4. Unit airflow configuration does not determine which drain connection to use. Either drain connection can be used with vertical or horizontal applications.

When using the standard side drain connection, ensure the red plug in the alternate bottom connection is tight. Do this before setting the unit in place.

The red drain pan can be tightened with a 1/2-in. square socket drive extension. To use the alternate bottom drain connection, remove the red drain plug from the bottom connection (use a 1/2-in. square socket drive extension) and install it in the side drain connection.

The piping for the condensate drain and external trap can be completed after the unit is in place. See Fig. 6

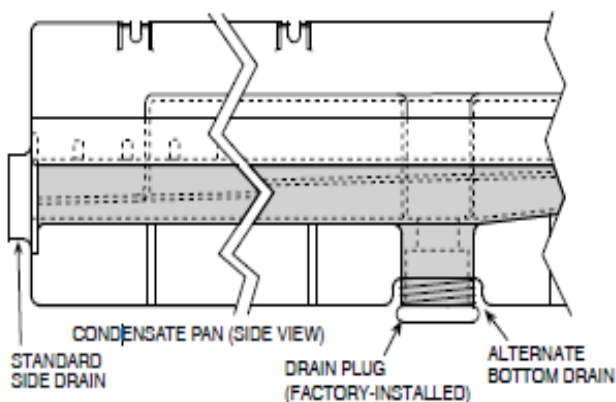
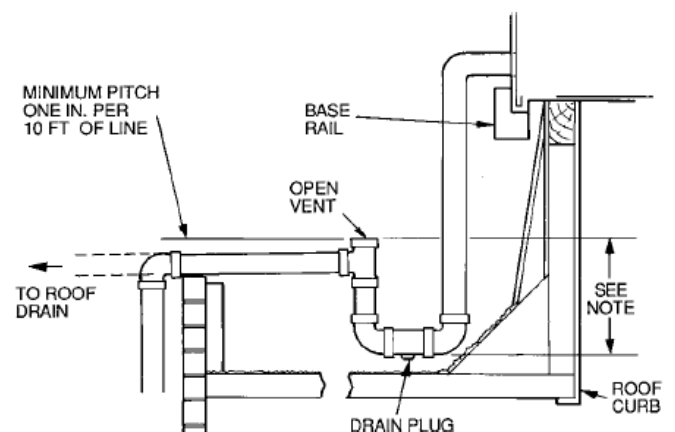

Fig. 5 Condensate Drain Details



NOTE: Trap should be deep enough to offset maximum unit static difference. A 4-in. trap is recommended.

Fig. 6 External Trap Condensate Drain

All units must have an external trap for condensate drainage. Install a trap at least 4-in. (102 mm) deep and protect against freeze-up. If drain line is installed downstream from the external trap, pitch the line away from the unit at 1-in. per 10 ft (25 mm in 3 m) of run. Do not use a pipe size smaller than the unit connection (3/4-in.).

2.9 – Make Electrical Connections

Field Power Supply – Unit is factory wired for voltage shown on nameplate. When installing units, provide disconnect as per NEC (National Electrical Code) requirements, of adequate size. All field wiring must comply with NEC and local

requirements. Route power lines through the corner post openings as shown in unit dimensional drawings. If a de-energize via a unit disconnect switch is desired, connect the source leads to the unit power terminal block. Refer to unit label diagram for additional information. Field power wires are connected to the unit power terminal block (see wiring diagram label for control box arrangement) max wire size is #4 AWG (copper only).

NOTE: Check all factory and field electrical connections for tightness. Field--supplied wiring shall conform to the limitations of 63°F (33°C) rise.

ELECTRIC SHOCK HAZARD

Failure to follow this warning could result in personal injury or death.

Do not use gas piping as an electrical ground. Unit cabinet must have an uninterrupted, unbroken electrical ground to minimize the possibility of personal injury if an electrical fault should occur. This ground may consist of electrical wire connected to unit ground lug in control compartment, or conduit approved for electrical ground when installed in accordance with local electrical codes or in absence of local codes, it is recommended that U.S.A standard ANSI/NFPA 70, National Electrical Code be followed.



WARNING

FIRE HAZARD

Failure to follow this warning could result in intermittent operation or performance satisfaction. Do not connect aluminum wire between disconnect and air conditioning unit. Use copper wire only (See Fig. 7)

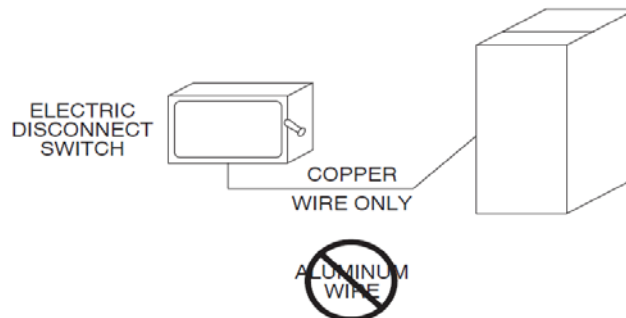

Fig. 7 Disconnect Switch and Unit

When installing units, provide a disconnect switch per NEC (National Electric Code) of adequate size. Disconnect sizing data is provided on the unit informative plate. Locate on unit cabinet or within sight of the unit per national or local codes. Do not cover unit informative plate if mounting the disconnect on the unit cabinet.

All field wiring must comply with the NEC and all local codes. Size wire based on MCA (Minimum Circuit Amps) on the unit informative plate, connections to the unit power terminal block and equipment ground. Maximum wire size is #4 ga AWG per pole.

Provide a ground-fault and short-circuit over-current protection device (fuse or breaker) per NEC Article 440 (or local codes). Refer to unit informative data plate for MOCP (Maximum Over-current Protection) device size. All field wiring must comply with NEC and local requirements.

1. Install power wiring conduit through side panel openings. Install conduit between disconnect and control box.
2. Install power lines to terminal block connections.

Voltage to compressor terminals during operation must be within voltage range indicated on unit nameplate. On 3-phase units, voltages between phases must be balanced within 2% and the current within 10%. Use the formula shown in the legend of the Electrical Data Table to determine the percent of voltage imbalance. Operation on improper lines voltage or excessive phase imbalance constitutes abuse and may cause damage to electrical components. Such operation would invalidate any applicable Carrier warranty.

Field Control Wiring – The 50TCM unit requires an external temperature control device. This device can be a thermostat (field-supplied) or a RTU Open controller (field-installed accessory, for use on a Carrier Comfort Network or as a standalone control)

Thermostat – Install a Carrier approved accessory thermostat according to installation instructions included with the accessory. Select a two-stage cooling thermostat. Locate the thermostat accessory on a solid wall in the conditioned space to sense average temperature in accordance with the thermostat installation instructions.

If the thermostat contains a logic circuit requiring 24v power, use a thermostat cable or equivalent single leads of different colors with minimum of seven leads. If the thermostat does not require a 24v source (no “C” connection required), use a thermostat cable or equivalent with minimum of six leads. Check the thermostat installation instructions for additional features which might require additional conductors in the cable.

For wire runs up to 15 m (50 ft.), use no. 18 AWG (American Wire Gage) insulated wire (35°C minimum). For 15 to 23 m (50 to 75 ft.), use no. 16 AWG insulated wire (35°C minimum). For over 23 m (75 ft.), use no. 14 AWG insulated wire (35°C minimum). All wire sizes larger than no. 18 AWG cannot be directly connected to the thermostat and will require a junction box and splice at the thermostat.

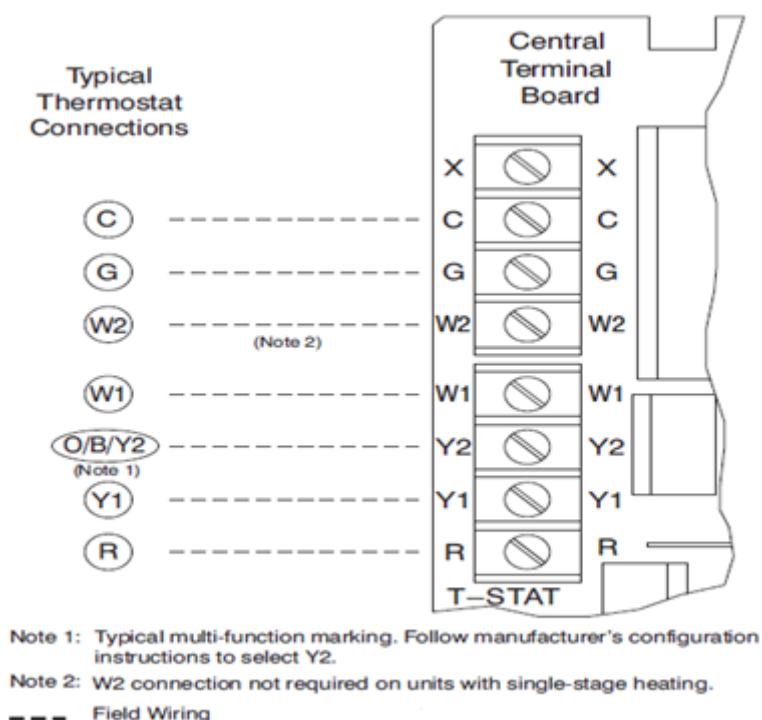

Fig. 8 Typical Low-Voltage Control Connections

3.0 – START-UP INSTRUCTIONS

PRIOR to unit start-up use the following instructions and start-up checklist provided on the last page.

3.1– Unit Preparation

Check that unit has been installed in accordance with these installation instructions and all applicable codes.

3.2 – Internal Wiring

Check all electrical connections in unit control boxes; tighten as required.

3.3 – Compressor Mounting

Compressors are internally spring mounted. Do not loosen or remove compressor hold down bolts.

3.4 – Refrigerant Service Ports

Each refrigerant system has a total of 2 Schrader type Service gage ports. One port is located on the suction line, one on the compressor discharge line, and one on the liquid line. In addition Schrader-type valves are located underneath the pressure switches. Be sure that caps on the ports are tight.

3.5 – Compressor Rotation

It is important to be certain the compressors are rotating in the proper direction. To determine whether or not compressors are rotating in the proper direction:

1. Connect service gages to suction and discharge pressure fittings.
2. Energize the compressor.
3. The suction pressure should drop and the discharge pressure should rise, as is normal on any start-up.

If the suction pressure does not drop and the discharge pressure does not rise to normal levels:

1. Note that the evaporator fan is probably also rotating in the wrong direction.
2. Turn off power to the unit.
3. Reverse any two of the compressor lead wires.
4. Turn on power to the compressor.
5. Check also phase monitor all ok green led before proceeding.

The suction and discharge pressure levels should now move to their normal start-up levels.



NOTE

IMPORTANT

For wire runs up to 50 ft, use no. 18 AWG insulated wire. For 50 to 75 ft, use no. 16 AWG insulated wire. For over 75 ft, use no. 14 AWG insulated wire. All wire larger than no. 18 AWG cannot be directly connected to the thermostat and will require a junction box and splice at the thermostat.

3.6 - Evaporator Fan

Fan belt and variable pulleys are factory installed. Remove tape from the fan pulley. See Table 4 Fan Performance data. Be sure that fans rotate in the proper direction. See Table 3 Fan RPM at various fan motor pulley settings. To alter fan performance, see Evaporator Fan Performance Adjustment section.

3.7– Condenser Fans and Motors

Fans and motors are factory set. Refer to Condenser-Fan Adjustment Section as required.

3.8– Return – Air Filters

Check that correct filters are installed in filter tracks. See Table 1 Physical data. Do not operate unit without return air filters.

3.9 – Base Unit Operation

COOLING, UNITS — when thermostat calls for cooling, terminals G and Y1 are energized. The indoor (evaporator) fan contactor (IFC), and compressor contactor no. 1 (C1) are energized and evaporator-fan motor, compressor no. 1 and condenser fans start. The condenser-fan motors run continuously while unit is cooling. If the thermostat calls for a second stage of cooling by energizing Y2, compressor contactor no. 2 (C2) is energized and compressor no. 2 starts.

HEATING, UNITS — (If Accessory or Optional Heater is installed) — upon a call for heating through terminal W1, IFC and heater contactor no. 1 (HC1) are energized.

Table – 3 Fan RPM at Motor Pulley Settings

Freq.	Unit 50TCM	Drive Package	MOTOR PULLEY TURNS OPEN - ENGLISH										
			0	1/3	1	1 1/3	2	2 1/3	3	3 1/3	4	4 1/3	5
50Hz	A07	Standard Static	1211	1176	1140	1104	1069	1033	998	962	926	891	855
		Medium Static	1449	1362	1330	1298	1267	1235	1203	1172	1140	1108	1077
	D08	Standard Static	808	784	760	736	713	689	665	641	618	594	570
		Medium Static	932	875	855	835	814	794	774	753	733	713	692
	D09	Standard Static	808	784	760	736	713	689	665	641	618	594	570
		Medium Static	932	875	855	835	814	794	774	753	733	713	692
	D12	Standard Static	808	784	760	736	713	689	665	641	618	594	570
		Medium Static	1087	1021	998	974	950	926	903	879	855	831	808
	D13	Standard Static	903	875	848	821	794	766	739	712	685	657	630
		Medium Static	1056	998	980	962	944	926	908	891	873	855	837

Bold RPM is factory setting

4.0 – SERVICE

4.1 – Cleaning

Inspect unit interior at beginning of each heating and cooling season and as operating conditions require. Remove unit top panel and/or side panels for access to unit interior.

EVAPORATOR COIL — Clean as required with a commercial coil cleaner.

CONDENSER COIL — Clean condenser coil annually and as required by location and outdoor-air conditions. Inspect coil monthly and clean as required.

CONDENSATE DRAIN — Check and clean each year at start of cooling season.

FILTERS — Clean or replace at start of each heating and cooling season, or more often if operating conditions require. Refer to Table 1 “Physical Data” type and size.

4.2 – Lubrication

Compressors are charged with the correct amount of oil at the factory.

Replacing Compressor - In the case of a motor burnout, the majority of contaminated will be removed with the compressor. The rest of the oil is cleaned through the use of suction and liquid line filter driers. A 100% activated alumna suction line filter drier is recommended but must be removed after 72 hours.

The compressor contains POE oil. POE oil has a high affinity for moisture. Do not remove the compressor’s tube plugs until ready to insert the unit suction and discharge tube ends. The discharge connection plug should be removed first before pulling the suction connection plug to allow the dry air pressure inside the compressor to escape.

Note: This is only valid for the R410A systems.



CAUTION

UNIT DAMAGE HAZARD

Failure to follow this caution may result in damage to components.

1. The compressor is in a Puron® refrigerant system and uses a (POE) lubricant Emkarate RL 32 3MAF. In the field the oil level could be topped up with Mobil EAL Arctic 22 CC if 3MAF is not available. POE oil is extremely hygroscopic, meaning it absorbs water readily. POE oils can absorb 15 times as much as other oils designed for HCFC and CFC refrigerants. Avoid exposure of the oil to the atmosphere.

2. Ensure that system is not subjected to liquid abuse. Turn the crankcase heater on 12 hours before starting the compressor.

CONDENSER AND EVAPORATOR-FAN MOTOR BEARINGS – The condenser and evaporator-fan motors have permanently-sealed bearings, so no field lubrication is necessary.

4.3 – Evaporator Fan Performance Adjustment

NOTE: To remove belts only, follow Steps 1, 2 & 6. Fan motor pulleys are factory set speed shown in Table 6.

To change fan speeds:

1. Shut off unit power supply.
2. Loosen belt by loosening fan motor mounting plate nuts. Slide the Motor and remove belt.
3. Loosen movable-pulley flange setscrew (See Fig.9).
4. Screw movable flange toward fixed flange to increase speed and away from fixed flange to decrease speed. Increasing fan speed increases load on motor. Do not exceed maximum speed specified in Table 3. See Table 4 for air flow.
5. Set movable flange at nearest keyway of pulley hub and tighten setscrew. (See Table 1 & 6 for speed change for each full turn of pulley flange.)
6. Replace and tighten belts. See Belt Tension Adjustment section on Table 1.

To align fan and motor pulleys:

1. Loosen fan pulley setscrews.
2. Slide fan pulley along fan shaft.
3. Make angular alignment by loosening motor from mounting plate.

4.4 – Evaporator Fan Service and Replacement

1. Remove supply-air section panel (The bolts holding the flexible connection to the panel should be removed).
2. Remove the Control Side panel.
3. Remove the Belt (refer to the previous section for Belt removal).
4. Remove the locking device of the hub & shaft from the both sides; it can be accessed through the fan side panel.
5. Pull the shaft gently from the control side, the blower will fall inside the blower housing.
6. Loosen the (lower) first two bolts from each side of the scroll fan housing mid-plate. This can be done from the supply panel side, now the fan can be removed easily from the supply panel side.
7. To assemble the fan, reverse the above procedure.

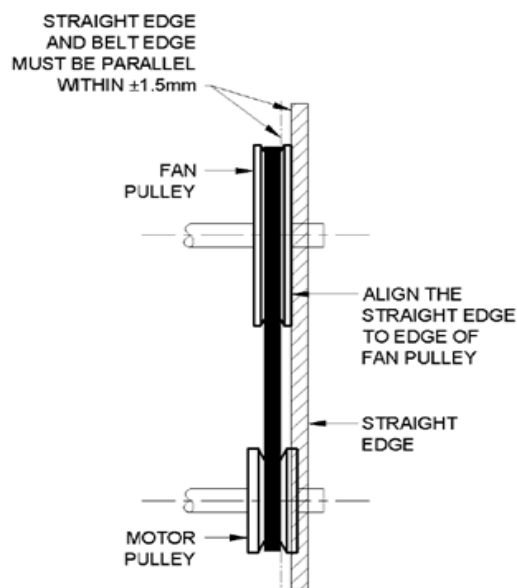

Fig. 9 Evaporator – Fan Pulley Alignment and Adjustment

4.5 – Belt Tension Adjustment.

To adjust belt tension:

1. Loosen fan motor bolts.
2. Adjust belt tension by sliding the motor on the mounting base.
3. Tighten nuts.
4. Adjust bolts and nut on mounting plate to secure motor in fixed position.

4.6 – Refrigerant Charge

Amount of refrigerant charge is listed on unit nameplate and in Table 1. Refer to Carrier GTAC II; Module 5; Charging, Recovery, Recycling, and Reclamation section for charging methods and procedures. Unit panels must be in place when unit is operating during charging procedure.

NOTE: Do not use recycled refrigerant as it may contain contaminants.

NO CHARGE — Use standard evacuating techniques. After evacuating system, weight in the specified amount of refrigerant (refer to Table 1).

LOW CHARGE COOLING — Using cooling charging chart according to the size of the unit Add or remove refrigerant until conditions of the chart are met. Note that charging chart is different from those normally used. An accurate pressure gage and temperature-sensing device is required. Charging is accomplished by ensuring the proper amount of liquid sub-cooling. Measure liquid line pressure at the liquid line service valve using pressure gage.

Connect temperature sensing device to the liquid line near the liquid line service valve and insulate it so that outdoor ambient temperature does not affect reading.

TO USE THE COOLING CHARGING CHART — Use the above temperature and pressure readings, and find the intersection point on the cooling charging chart. If intersection point on chart is above line, add refrigerant. If intersection point on chart is below line, carefully recover some of the charge. Recheck suction pressure as charge is adjusted.

NOTE: Indoor-air CFM must be within normal operating range of unit. All outdoor fans must be operating.

4.7 – Protective Devices

Compressor Protection – Each compressor is internally protected against over temperature.

To reset, manually move the thermostat setting.

Evaporator and Condenser-fan Motor Protection — Each Evaporator and Condenser-fan motor is internally protected against over temperature.

High and Low-Pressure switches — If either switch trips, it will be automatically reset when fault is cleared.



NOTE

IMPORTANT

After prolonged shutdown or servicing in cold weather, energize the crankcase heaters for 12 hours before starting the compressors.

4.8 – Control Circuit, 24-V

This control circuit is protected against over-current by a circuit breaker. Breaker can be reset manually if it trips, determine cause of trouble before resetting.

5.0 – REPLACEMENT PARTS

A complete list of replacement parts may be obtained from any Carrier distributor.

Table - 4 Electrical Data

50TCM			Compressor				OFM			IFM		Electric Heater			MCA	MOCP
Unit Size	Drive package Indoor Motor	Power Supply V / Ph / Hz	No.1		No.2		Qty	HP	FLA	HP	FLA	Heater P.N	Application (KW)	FLA		
			RLA	LRA	RLA	LRA										
A07	Standard	400/3/50 - 415/3/50	9.74	64.0	-	-	1	1/3	2.4	1.4	2.6	-	-	-	17.2	25
			9.74	64.0	-	-	1	1/3	2.4	1.4	2.6	CRHEATER106A00	4.2	6.0	17.5	25
			9.74	64.0	-	-	1	1/3	2.4	1.4	2.6	CRHEATER108A00	8.0	11.5	17.6	25
			9.74	64.0	-	-	1	1/3	2.4	1.4	2.6	CRHEATER109A00	9.7	14.0	20.8	25
			9.74	64.0	-	-	1	1/3	2.4	1.4	2.6	CRHEATER108A00,108A00	16.0	23.1	32.1	40
			9.74	64.0	-	-	1	1/3	2.4	1.4	2.6	CRHEATER108A00,109A00	17.7	25.6	35.3	40
	Medium	400/3/50 - 415/3/50	9.74	64.0	-	-	1	1/3	1.6	2.9	4.5	-	0	0.0	18.3	25
			9.74	64.0	-	-	1	1/3	1.6	2.9	4.5	CRHEATER106A00	4.2	6.0	18.3	25
			9.74	64.0	-	-	1	1/3	1.6	2.9	4.5	CRHEATER108A00	8.0	11.5	20.0	25
			9.74	64.0	-	-	1	1/3	1.6	2.9	4.5	CRHEATER109A00	9.7	14.0	23.1	25
			9.74	64.0	-	-	1	1/3	1.6	2.9	4.5	CRHEATER108A00,108A00	16.0	23.1	34.5	35
			9.74	64.0	-	-	1	1/3	1.6	2.9	4.5	CRHEATER108A00,109A00	17.7	25.6	37.6	40
D08	Standard	400/3/50 - 415/3/50	6.1	43.0	6.1	43.0	2	1/3	1.4	2.4	3	-	-	-	19.5	25
			6.1	43.0	6.1	43.0	2	1/3	1.4	2.4	3	CRHEATER116A00	9.7	13.9	21.1	25
			6.1	43.0	6.1	43.0	2	1/3	1.4	2.4	3	CRHEATER113A00	11.5	16.5	24.5	25
			6.1	43.0	6.1	43.0	2	1/3	1.4	2.4	3	CRHEATER114A00	19.3	27.9	38.6	40
			6.1	43.0	6.1	43.0	2	1/3	1.4	2.4	3	CRHEATER115A00	22.9	33.1	45.1	50
			6.1	43.0	6.1	43.0	2	1/3	1.4	2.4	3	CRHEATER114A00,116A00	29.0	41.8	56.0	60
	Medium	400/3/50 - 415/3/50	6.1	43.0	6.1	43.0	2	1/3	1.4	2.9	4.5	-	-	-	21.0	25
			6.1	43.0	6.1	43.0	2	1/3	1.4	2.9	4.5	CRHEATER116A00	9.7	13.9	23.0	25
			6.1	43.0	6.1	43.0	2	1/3	1.4	2.9	4.5	CRHEATER113A00	11.5	16.5	26.3	30
			6.1	43.0	6.1	43.0	2	1/3	1.4	2.9	4.5	CRHEATER114A00	19.3	27.9	40.5	50
			6.1	43.0	6.1	43.0	2	1/3	1.4	2.9	4.5	CRHEATER115A00	22.9	33.1	47.0	50
			6.1	43.0	6.1	43.0	2	1/3	1.4	2.9	4.5	CRHEATER114A00,116A00	29.0	41.8	58.0	60
D09	Standard	400/3/50 - 415/3/50	6.8	51.5	6.2	52.0	1	1	3.4	2.4	3	-	0	0.0	21.1	25
			6.8	51.5	6.2	52.0	1	1	3.4	2.4	3	CRHEATER116A00	9.7	13.9	21.1	25
			6.8	51.5	6.2	52.0	1	1	3.4	2.4	3	CRHEATER113A00	11.5	16.5	24.5	25
			6.8	51.5	6.2	52.0	1	1	3.4	2.4	3	CRHEATER114A00	19.3	27.9	38.6	40
			6.8	51.5	6.2	52.0	1	1	3.4	2.4	3	CRHEATER115A00	22.9	33.1	45.1	50
			6.8	51.5	6.2	52.0	1	1	3.4	2.4	3	CRHEATER114A00,116A00	29.0	41.8	56.0	60
	Medium	400/3/50 - 415/3/50	6.8	51.5	6.2	52.0	1	1	3.4	2.9	4.5	-	-	-	22.6	30
			6.8	51.5	6.2	52.0	1	1	3.4	2.9	4.5	CRHEATER116A00	9.7	13.9	23.0	30
			6.8	51.5	6.2	52.0	1	1	3.4	2.9	4.5	CRHEATER113A00	11.5	16.5	26.3	30
			6.8	51.5	6.2	52.0	1	1	3.4	2.9	4.5	CRHEATER114A00	19.3	27.9	40.5	50
			6.8	51.5	6.2	52.0	1	1	3.4	2.9	4.5	CRHEATER115A00	22.9	33.1	47.0	50
			6.8	51.5	6.2	52.0	1	1	3.4	2.9	4.5	CRHEATER114A00,116A00	29.0	41.8	57.9	60

Legend and Notes for Electrical Data Table

- FLA - Full Load Amps
- IFM - Indoor (Evaporator) Fan Motor
- LRA - Locked Rotor Amps
- MCA - Minimum Circuit Amps
- Minimum Voltage: 360V , Maximum Voltage: 440V on 400/3/50
- OFM - Outdoor (Condenser) Fan Motor
- RLA - Rated Load Amps
- APP - Application power at rated power supply voltage
- MOCP - Maximum Overcurrent Protection

Unbalanced 3-Phase Supply Voltage

Never operate a motor where phase imbalance in supply voltage is greater than 2%.

Use the following formula to determine the percentage of voltage imbalance

$$= 100 \times \frac{\text{Maximum Deviation From Average Voltage}}{\text{Average Voltage}}$$

Determine maximum deviation from average voltage.

- (AB) 397 - 392 =5v
- (BC) 404 - 397 =7v
- (AC) 457 - 397 =2v

AB = 392v	Average Voltage = $\frac{392 + 404 + 395}{3}$
BC = 404v	
AC = 395v	$= \frac{1191}{3} = 397V$

Maximum Deviation is 7v.
Determine Percentage Voltage Imbalance.

$$\% \text{ Voltage Imbalance} = 100 \times \frac{7}{397} = 1.76\%$$

This amount of phase imbalance is satisfactory as it is below the maximum allowable 2%

IMPORTANT: If the supply voltage phase imbalance is more than 2% contact your local electric utility company

Table - 4 Electrical Data (Continued)

50TCM			Compressor				OFM			IFM		Electric Heater			MCA	MOCP
Unit Size	Drive package Indoor Motor	Power Supply V / Ph / Hz	No.1		No.2		Qty	HP	FLA	HP	FLA	Heater P.N	Application (KW)	FLA		
			RLA	LRA	RLA	LRA										
D12	Standard	400/3/50 - 415/3/50	7.8	51.5	7.8	51.5	1	1	3.4	2.4	3	-	-	-	24.0	30
			7.8	51.5	7.8	51.5	1	1	3.4	2.4	3	CRHEATER116A00	9.7	13.9	24.0	30
			7.8	51.5	7.8	51.5	1	1	3.4	2.4	3	CRHEATER113A00	11.5	16.5	24.4	30
			7.8	51.5	7.8	51.5	1	1	3.4	2.4	3	CRHEATER114A00	19.3	27.9	38.6	40
			7.8	51.5	7.8	51.5	1	1	3.4	2.4	3	CRHEATER115A00	22.9	33.1	45.1	50
			7.8	51.5	7.8	51.5	1	1	3.4	2.4	3	CRHEATER114A00,116A00	29	41.8	56.0	60
	Medium	400/3/50 - 415/3/50	7.8	51.5	7.8	51.5	1	1	3.4	3.7	4.4	-	0	0.0	25.4	30
			7.8	51.5	7.8	51.5	1	1	3.4	3.7	4.4	CRHEATER116A00	9.7	13.9	25.4	30
			7.8	51.5	7.8	51.5	1	1	3.4	3.7	4.4	CRHEATER113A00	11.5	16.5	26.1	30
			7.8	51.5	7.8	51.5	1	1	3.4	3.7	4.4	CRHEATER114A00	19.3	27.9	40.4	50
			7.8	51.5	7.8	51.5	1	1	3.4	3.7	4.4	CRHEATER115A00	22.9	33.1	46.9	50
			7.8	51.5	7.8	51.5	1	1	3.4	3.7	4.4	CRHEATER114A00,116A00	29	41.8	57.8	60
D13	Standard	400/3/50 - 415/3/50	10.6	75	11	75	1	1	7	2.9	3.91	-	-	-	24.2	30
			10.6	75	11	75	1	1	7	2.9	3.91	CRHEATER116A00	9.7	13.9	24.2	30
			10.6	75	11	75	1	1	7	2.9	3.91	CRHEATER113A00	11.5	16.5	24.2	30
			10.6	75	11	75	1	1	7	2.9	3.91	CRHEATER114A00	19.3	27.9	24.2	30
			10.6	75	11	75	1	1	7	2.9	3.91	CRHEATER115A00	22.9	33.1	24.2	40
			10.6	75	11	75	1	1	7	2.9	3.91	CRHEATER114A00,116A00	29	41.8	24.2	50
	Medium	400/3/50 - 415/3/50	10.6	75	11	75	1	1	7	3.9	7.5	-	-	-	27.8	30
			10.6	75	11	75	1	1	7	3.9	7.5	CRHEATER116A00	9.7	13.9	27.8	30
			10.6	75	11	75	1	1	7	3.9	7.5	CRHEATER113A00	11.5	16.5	27.8	30
			10.6	75	11	75	1	1	7	3.9	7.5	CRHEATER114A00	19.3	27.9	27.8	40
			10.6	75	11	75	1	1	7	3.9	7.5	CRHEATER115A00	22.9	33.1	27.8	40
			10.6	75	11	75	1	1	7	3.9	7.5	CRHEATER114A00,116A00	29	41.8	27.8	50

Legend and Notes for Electrical Data Table

- FLA - Full Load Amps
- IFM - Indoor (Evaporator) Fan Motor
- LRA - Locked Rotor Amps
- MCA - Minimum Circuit Amps
- Minimum Voltage: 360V , Maximum Voltage: 440V on 400/3/50
- OFM - Outdoor (Condenser) Fan Motor
- RLA - Rated Load Amps
- APP - Application power at rated power supply voltage
- MOCP - Maximum Overcurrent Protection

Unbalanced 3-Phase Supply Voltage

Never operate a motor where phase imbalance in supply voltage is greater than 2%.

Use the following formula to determine the percentage of voltage imbalance

$$= 100 \times \frac{\text{Maximum Deviation From Average Voltage}}{\text{Average Voltage}}$$

Determine maximum deviation from average voltage.

- (AB) 397 - 392 =5v
- (BC) 404 - 397 =7v
- (AC) 457 - 397 =2v

Maximum Deviation is 7v.

AB = 392v	Average Voltage = $\frac{392 + 404 + 395}{3}$
BC = 404v	
AC = 395v	$= \frac{1191}{3} = 397V$

Determine Percentage Voltage Imbalance.

$$\% \text{ Voltage Imbalance} = 100 \times \frac{7}{397} = 1.76\%$$

This amount of phase imbalance is satisfactory as it is below the maximum allowable 2%

IMPORTANT: If the supply voltage phase imbalance is more than 2% contact your local electric utility company

Typical Wiring Schematic - Series A - 50TCMA07

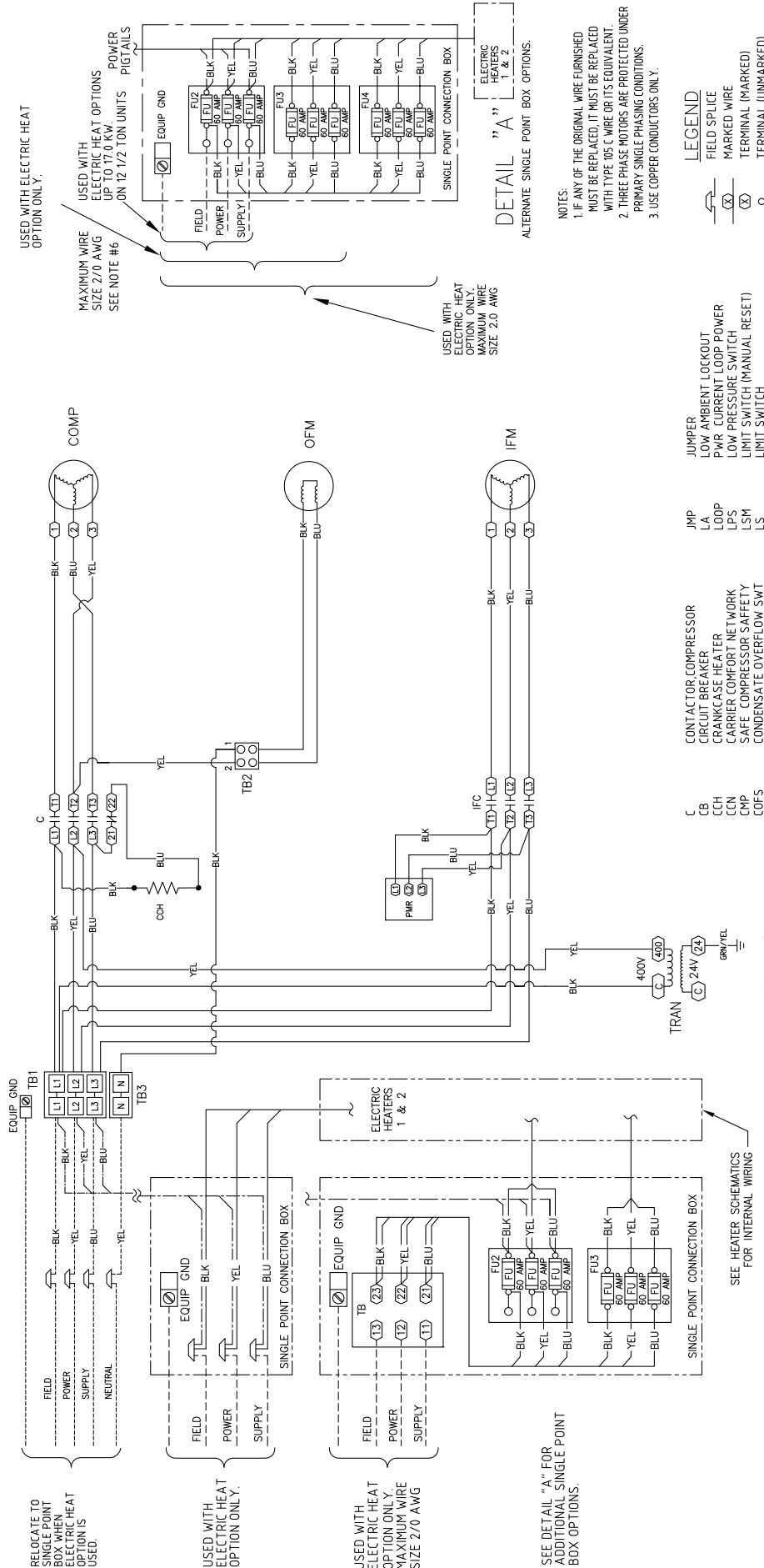

- NOTES:**
1. IF ANY OF THE ORIGINAL WIRE FURNISHED MUST BE REPLACED, IT MUST BE REPLACED WITH TYPE 105 °C WIRE OR ITS EQUIVALENT.
 2. THREE PHASE MOTORS ARE PROTECTED UNDER PRIMARY SINGLE PHASING CONDITIONS.
 3. USE COPPER CONDUCTORS ONLY.

LEGEND

- JUMPER
- LOW AMBIENT LOCKOUT
- PWR CURRENT LOOP POWER
- LOW PRESSURE SWITCH
- LIMIT SWITCH (MANUAL RESET)
- LIMIT SWITCH
- OUTDOOR AIR QUALITY
- OUTDOOR AIR TEMP SEN
- OUTDOOR FAN MOTOR
- OVERLOAD
- PLUG ASSEMBLY
- POTENTIOMETER
- PHASE MONITOR RELAY
- QUADRUPLE TERMINAL RELAY
- RETURN AIR TEMP SEN
- REMOTE OCCUPANCY
- SUPPLY AIR TEMP. SENSOR
- SENSOR
- SET POINT OFFSET
- SUPPLY FAN STATUS
- TIME DELAY RELAY (WINTER START)
- TRANSFORMER
- VARIABLE FREQUENCY DRIVE

- JMP JUMPER
- LA LOW AMBIENT LOCKOUT
- PWR CURRENT LOOP POWER
- LPS LOW PRESSURE SWITCH
- LSM LIMIT SWITCH (MANUAL RESET)
- LS LIMIT SWITCH
- DAQ OUTDOOR AIR QUALITY
- OAT OUTDOOR AIR TEMP SEN
- OFM OUTDOOR FAN MOTOR
- OL OVERLOAD
- PL PLUG ASSEMBLY
- POT POTENTIOMETER
- PMR PHASE MONITOR RELAY
- QTR QUADRUPLE TERMINAL RELAY
- RAT RETURN AIR TEMP SEN
- ROCC REMOTE OCCUPANCY
- SAT SUPPLY AIR TEMP. SENSOR
- SEN SENSOR
- SPO SET POINT OFFSET
- SFS SUPPLY FAN STATUS
- TDR TIME DELAY RELAY (WINTER START)
- TRN TRANSFORMER
- VFD VARIABLE FREQUENCY DRIVE

- CB CONTACTOR/COMPRESSOR
- CB CIRCUIT BREAKER
- CCH CRANKCASE HEATER
- CCN CARRIER COMPRESSOR NETWORK
- CCM SAFE COMPRESSOR SAFETY
- COFS CONDENSATE OVERFLOW SWT
- COMP COMPRESSOR MOTOR
- CR CONTROL RELAY
- CTB CENTRAL TERMINAL BOARD
- DDC DIRECT DIGITAL CONTROL
- ERV ENERGY RECOVERY VENTILATOR
- FAC FACTORY INSTALLED OPTION
- FSH FIRE SHUT DOWN
- FUSE FUSE
- GND GROUND
- HC HEATER CONTACTOR
- HPS HIGH PRESSURE SWITCH
- IQA INDOOR AIR QUALITY SENSORS
- IAC INDOOR FAN CONTACTOR
- IFCB INDOOR FAN CIRCUIT BREAKER
- IFTB INDOOR FAN TERMINAL BLOCK
- IFM INDOOR FAN MOTOR
- IRH INDOOR RELATIVE HUMIDITY

- C
- CB
- CCH
- CCN
- CCM
- COFS
- COMP
- CR
- CTB
- DDC
- ERV
- FAC
- FSD
- FU
- GND
- HC
- HPS
- IQA
- IAC
- IFCB
- IFTB
- IFM
- IRH

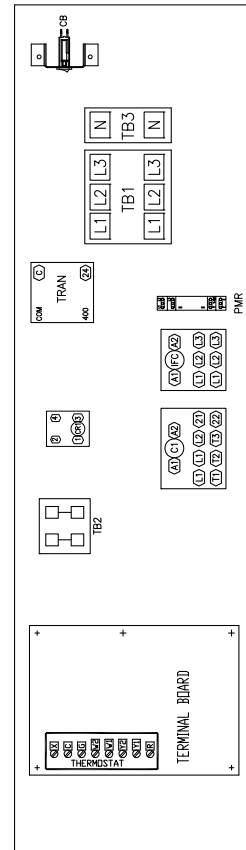

Typical Wiring Schematic - Series A - 50TCMA09/12

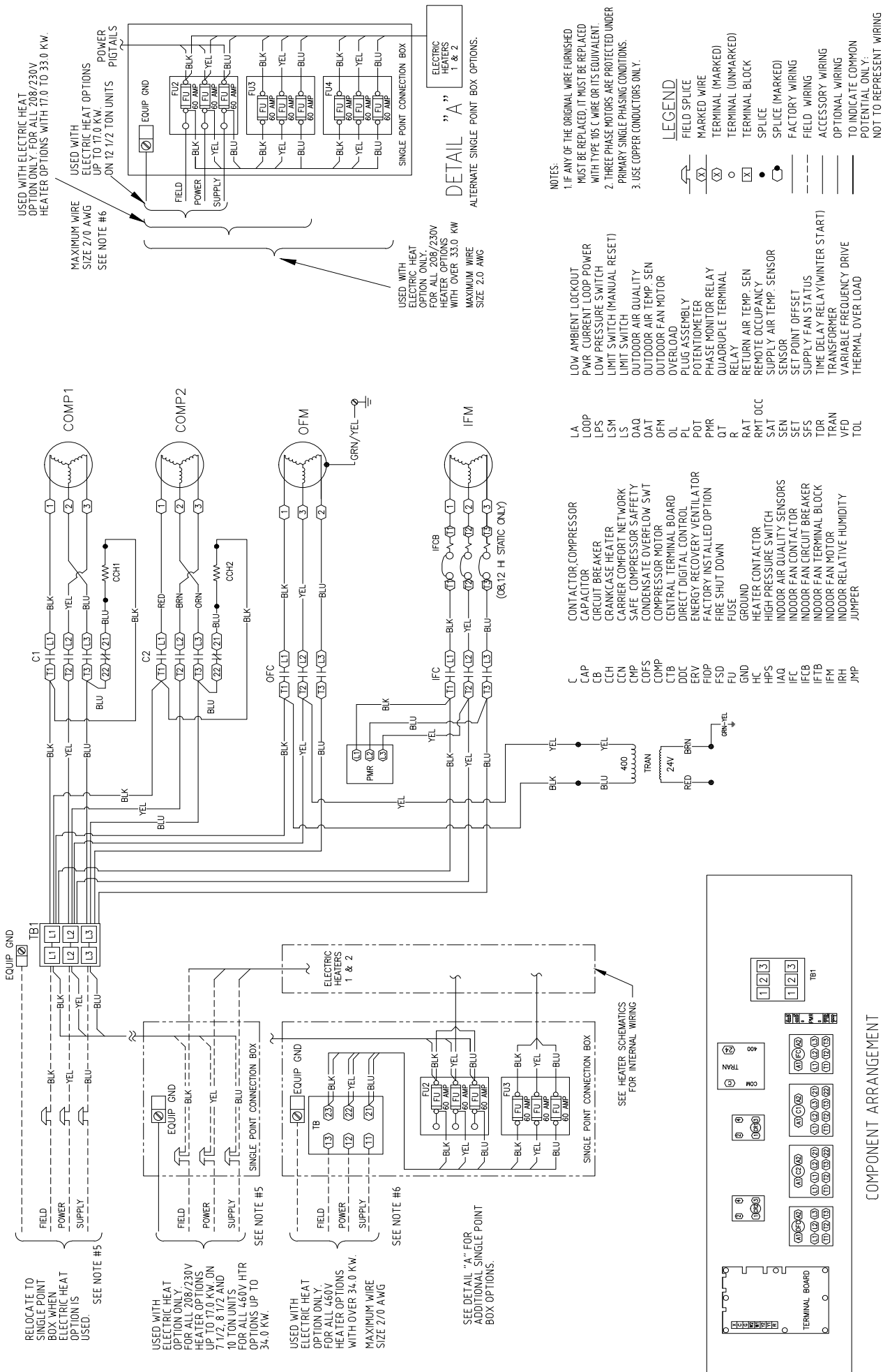

Typical Control Schematic - Series A - 50TCMD08/09/12/13

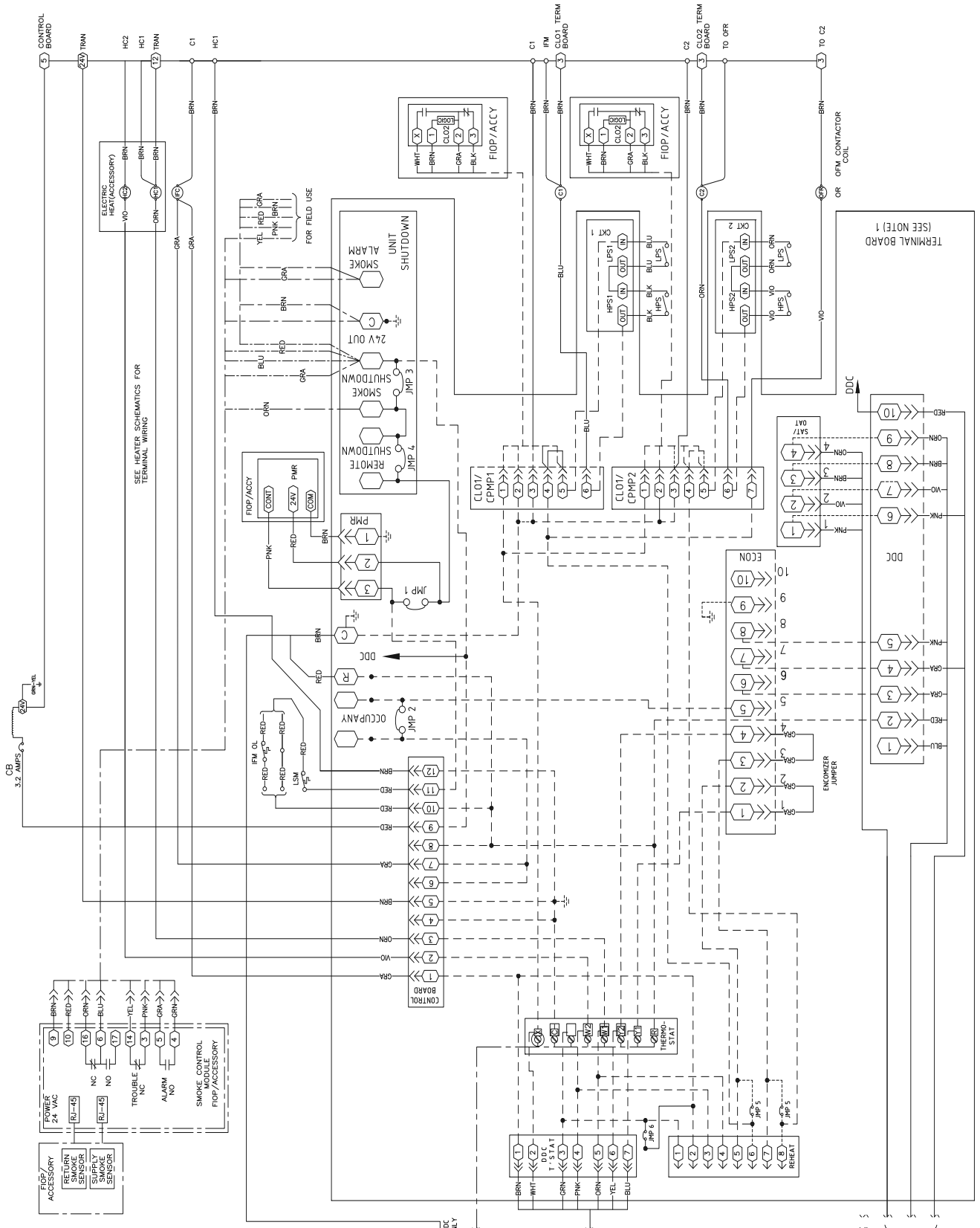

NOTES:

1. TERMINAL BOARD SCHEMATIC LAYOUT DOES NOT MATCH ACTUAL TERMINAL BOARD TO SIMPLIFY CIRCUIT TRACE
2. ENSURE DESIGNATED JUMPERS ON TERMINAL BOARD ARE CUT WHEN ADDING SMOKE DETECTORS, PHASE LOSS REPLY, OCCUPANCY AND SHUTDOWN.
3. FOR SINGLE STAGE ELECTRIC HEAT OPTION MOVE VIOLET WIRE FROM TB4 VIOLET TO TB4 ORANGE
4. TB4 LOCATED IN HEAT SECTION.

Typical Wiring Schematic - Series B - 50TCMA07

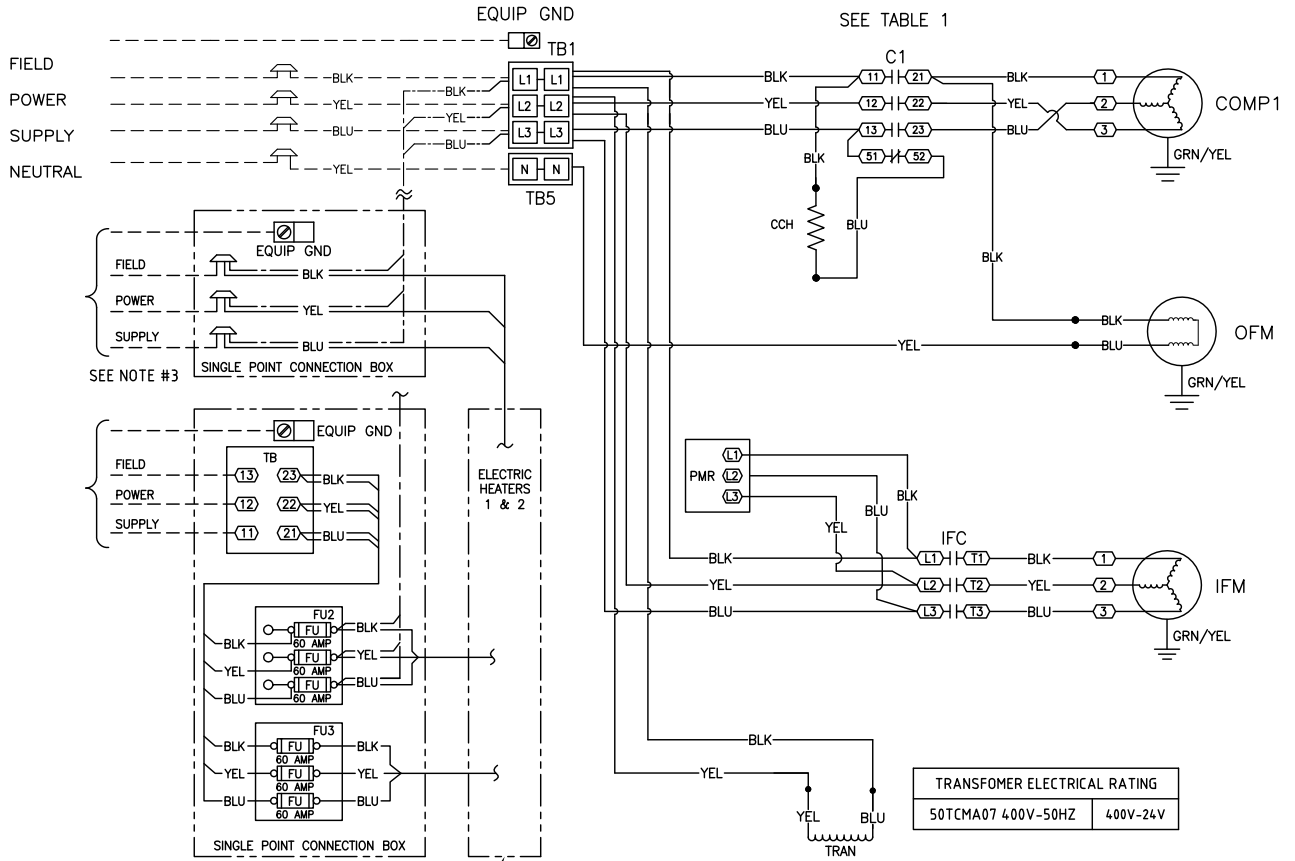

TRANSFORMER ELECTRICAL RATING	
50TCMA07 400V-50HZ	400V-24V

NOTES:

1. IF ANY OF THE ORIGINAL WIRE FURNISHED MUST BE REPLACED, IT MUST BE REPLACED WITH TYPE 105° C WIRE OR ITS EQUIVALENT.
2. THREE PHASE MOTORS ARE PROTECTED UNDERPRIMARY SINGLE PHASING CONDITIONS.
3. USE COPPER CONDUCTORS ONLY.
4. IFM WITHOUT OVERLOAD CONNECT RED WIRE TOGETHER

LEGEND

- FIELD SPLICE
- MARKED WIRE
- TERMINAL (MARKED)
- TERMINAL (UNMARKED)
- TERMINAL BLOCK
- SPLICE
- SPLICE (MARKED)
- FACTORY WIRING
- FIELD WIRING
- ACCESSORY WIRING
- OPTIONAL WIRING
- TO INDICATE COMMON POTENTIAL ONLY: NOT TO REPRESENT WIRING

- C CONTACTOR, COMPRESSOR
- CB CIRCUIT BREAKER
- COMP COMPRESSOR MOTOR
- EQUIP EQUIPMENT
- GND GROUND
- HC HEATER CONTACTOR
- HPS HIGH PRESSURE SWITCH
- IFC INDOOR FAN CONTACTOR
- IFM INDOOR FAN MOTOR
- IFM/OL INDOOR FAN MOTOR OVER LOAD
- LPS LOW PRESSURE SWITCH
- LSM LIMIT SWITCH (MANUAL RESET)
- OFM OUTDOOR FAN MOTOR
- OFR OUTDOOR FAN RELAY
- PMR PHASE MONITOR RELAY
- TB TERMINAL BOARD
- TRAN TRANSFORMER

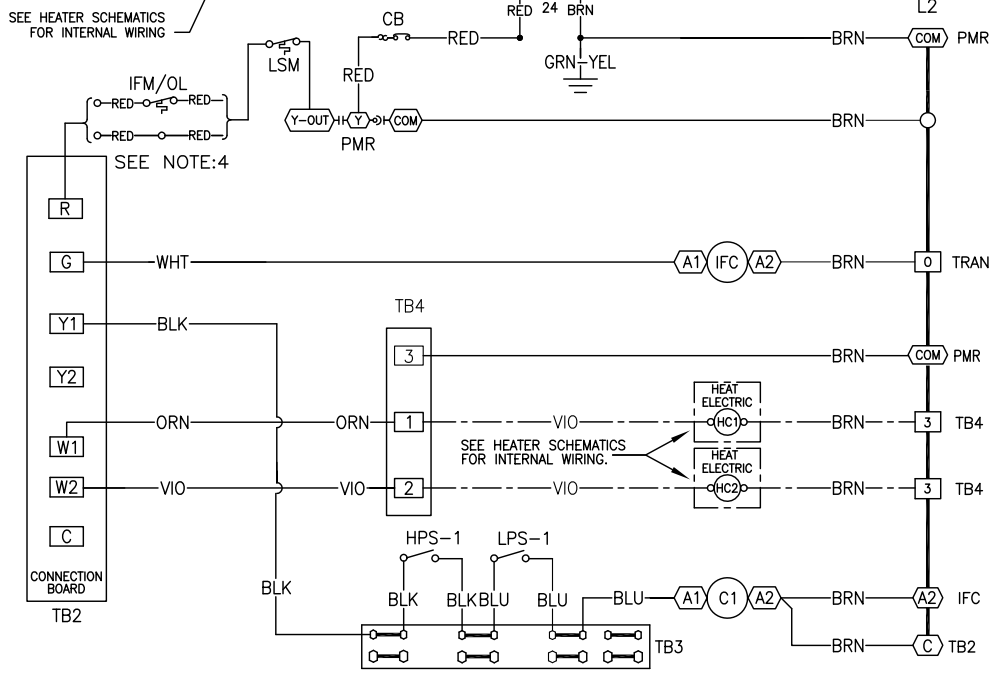
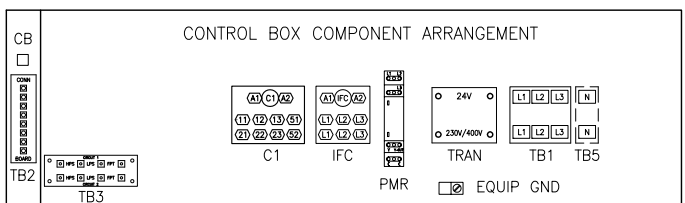
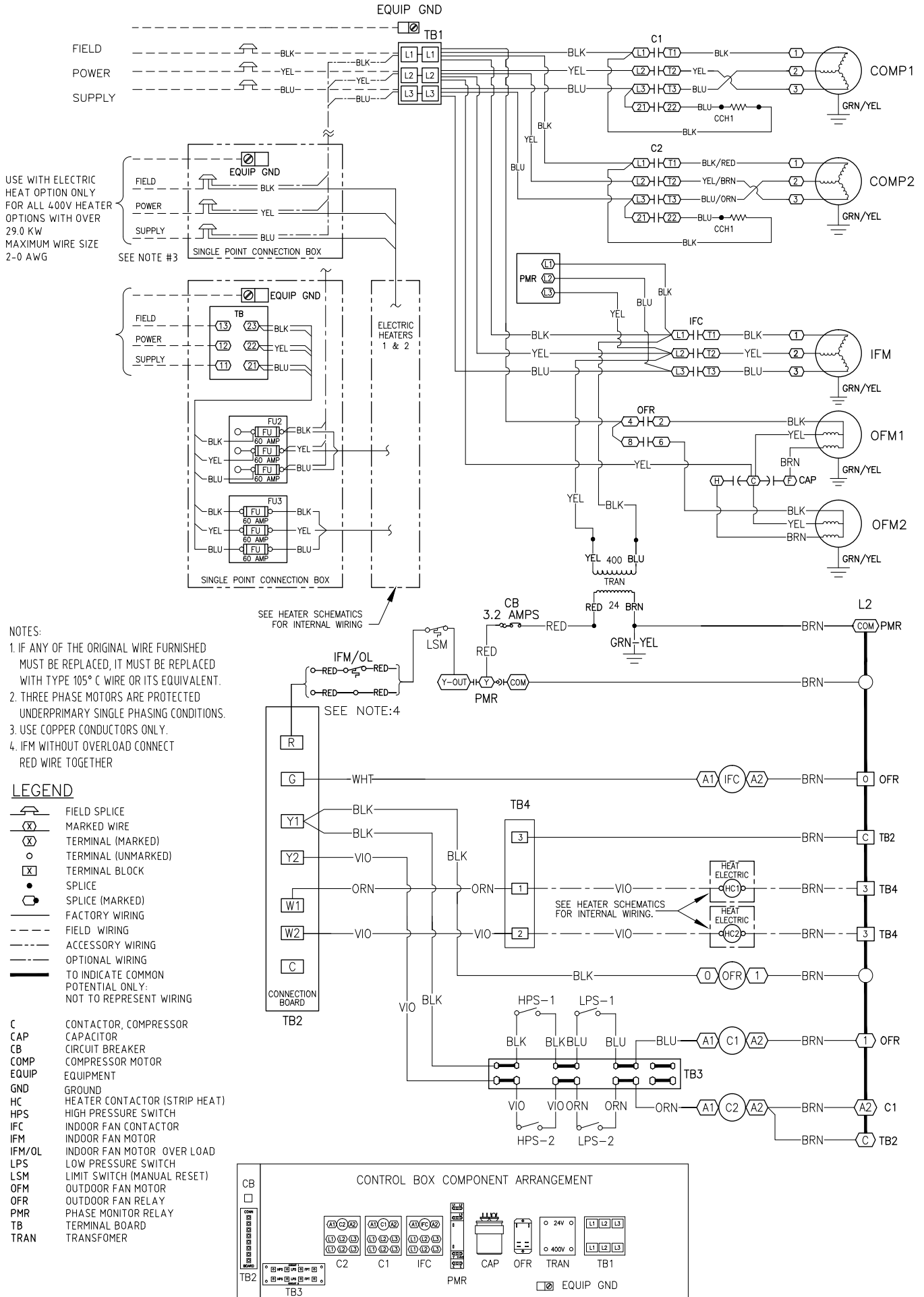

TABLE 1 TERMINAL CONFIGURATION OF C1	
400V-50HZ	400V-60HZ/ 230V-60HZ
C1 L1-T1	C1 11-T1
L2-T2	12-T2
L3-T3	13-T3
21-T2	51-T2



Typical Wiring Schematic - Series B - 50TCMD08



Typical Wiring Schematic - Series B - 50TCMD09/12

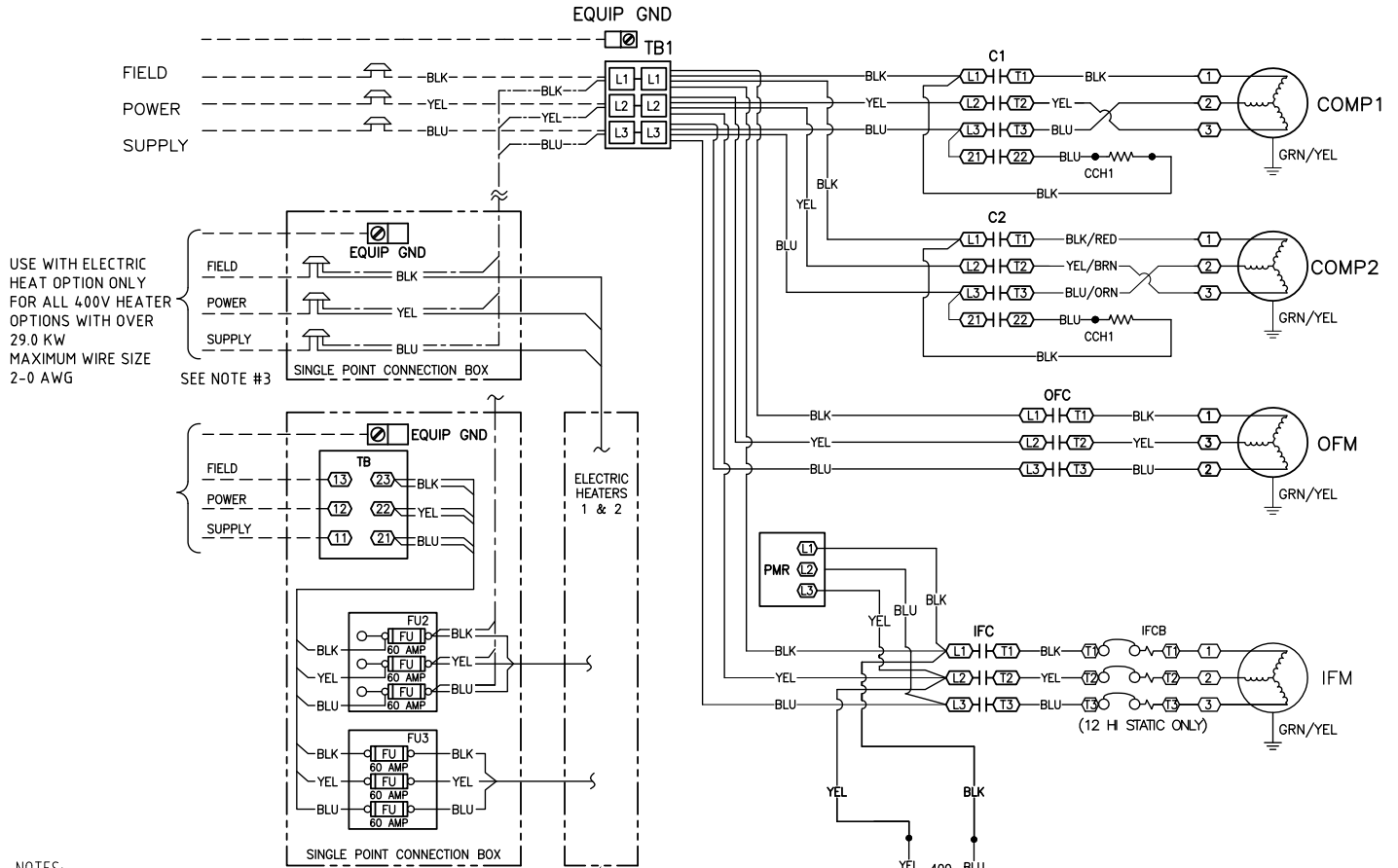

NOTES:

1. IF ANY OF THE ORIGINAL WIRE FURNISHED MUST BE REPLACED, IT MUST BE REPLACED WITH TYPE 105° C WIRE OR ITS EQUIVALENT.
2. THREE PHASE MOTORS ARE PROTECTED UNDERPRIMARY SINGLE PHASING CONDITIONS.
3. USE COPPER CONDUCTORS ONLY.
4. IFM WITHOUT OVERLOAD CONNECT RED WIRE TOGETHER
5. TOL CONNECTION ONLY FOR MOTOR HAVING EXTERNAL THERMAL OVER LOAD CONNECTION

LEGEND

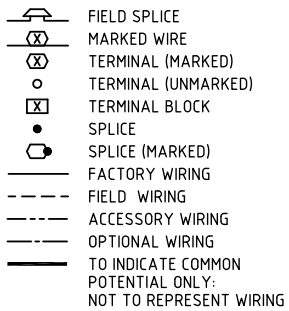

C	CONTACTOR, COMPRESSOR
CAP	CAPACITOR
CB	CIRCUIT BREAKER
COMP	COMPRESSOR MOTOR
EQUIP	EQUIPMENT
GND	GROUND
HC	HEATER CONTACTOR (STRIP HEAT)
HPS	HIGH PRESSURE SWITCH
IFC	INDOOR FAN CONTACTOR
IFM	INDOOR FAN MOTOR
IFCB	INDOOR FAN CIRCUIT BREAKER
IFM/OL	INDOOR FAN MOTOR OVER LOAD
IFR	INDOOR FAN RELAY
LPS	LOW PRESSURE SWITCH
LSM	LIMIT SWITCH (MANUAL RESET)
OFM	OUTDOOR FAN MOTOR
OFC	OUTDOOR FAN RELAY
PMR	PHASE MONITOR RELAY
TB	TERMINAL BOARD
TOL	THERMAL OVER LOAD
TRAN	TRANSFORMER

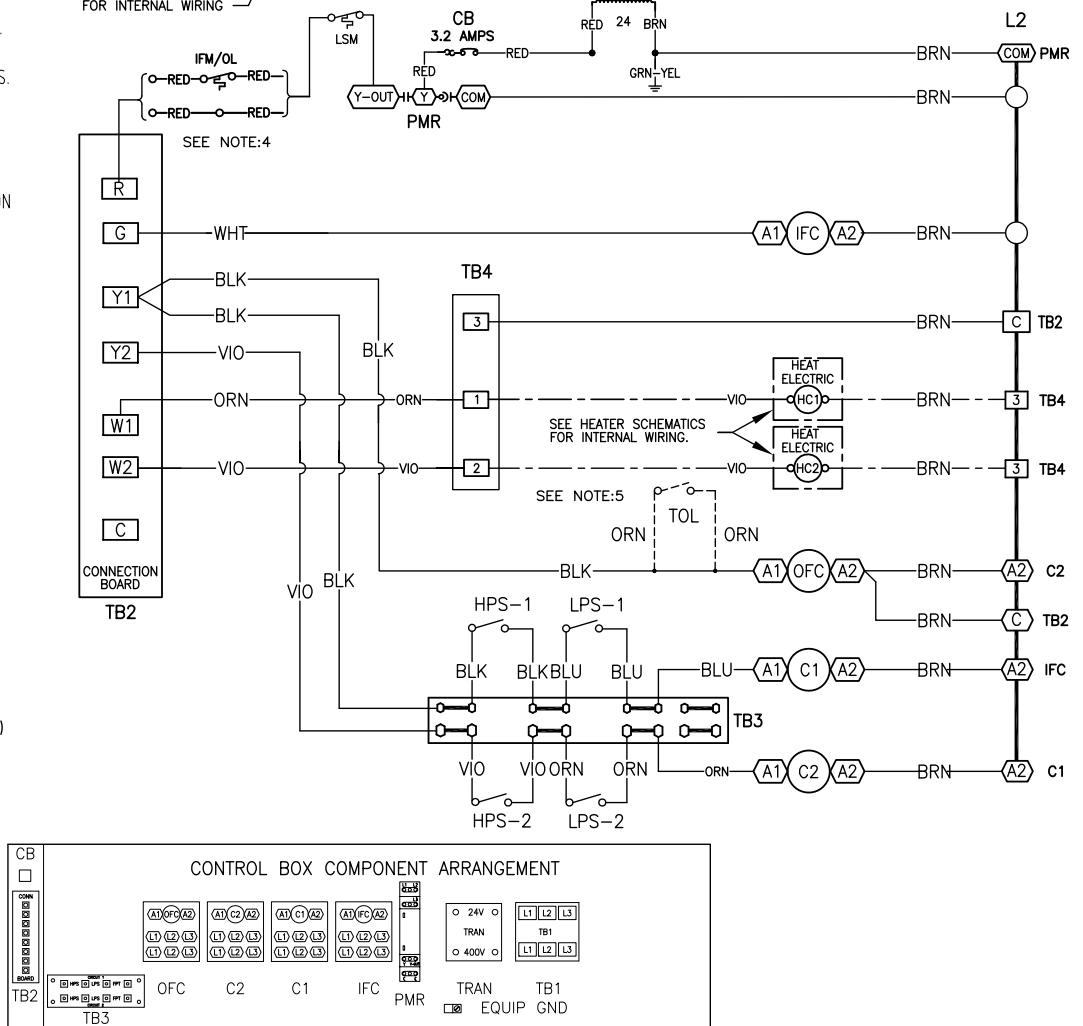

Typical Wiring Schematic - Series B - 50TCMD13

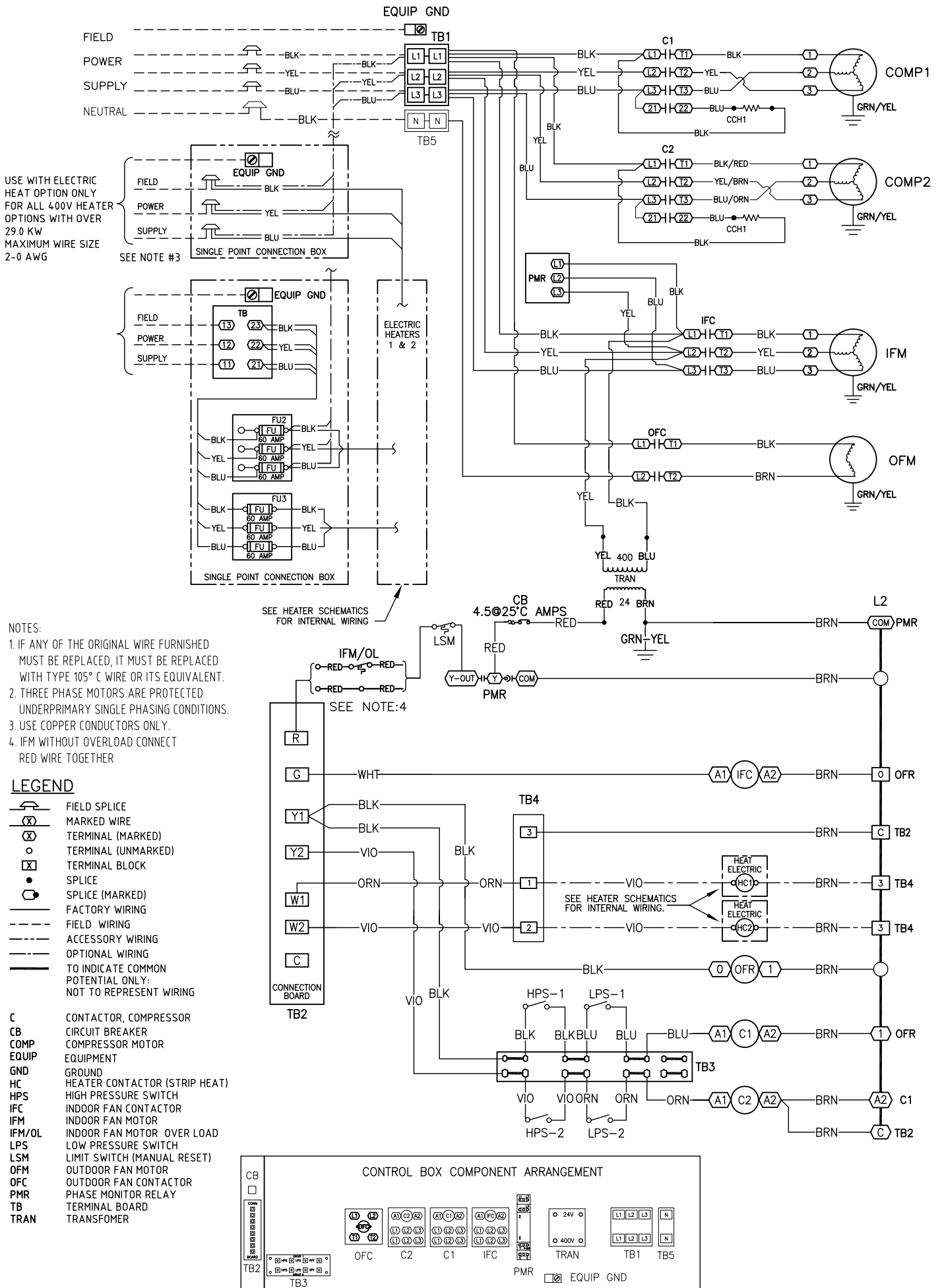

Table 5 - Fan Performance

Unit 50TCM - A07 - 6 Tons - 400V - 50Hz

Air Flow Rate (CFM)	Available External Static Pressure (in. wg)														
	0.2			0.4			0.6			0.8			1.0		
	RPM	KWI	BHP	RPM	KWI	BHP	RPM	KWI	BHP	RPM	KWI	BHP	RPM	KWI	BHP
1800	785	0.48	0.51	885	0.62	0.66	972	0.76	0.82	1051	0.91	0.98	1121	1.07	1.15
1950	833	0.58	0.62	929	0.74	0.79	1013	0.89	0.95	1089	1.05	1.13	1158	1.21	1.31
2100	881	0.70	0.75	973	0.86	0.92	1054	1.03	1.10	1129	1.20	1.29	1197	1.36	1.48
2250	930	0.84	0.90	1019	1.01	1.08	1097	1.18	1.27	1169	1.34	1.46	1236	1.53	1.66
2400	980	0.99	1.06	1065	1.17	1.26	1141	1.36	1.46	1211	1.53	1.66	1276	1.72	1.87
2550	1030	1.17	1.25	1112	1.36	1.46	1185	1.54	1.67	1253	1.73	1.88	1317	1.93	2.10
2700	1081	1.34	1.46	1159	1.54	1.67	1231	1.75	1.90	1297	1.95	2.12	1358	2.16	2.35
2850	1133	1.56	1.69	1207	1.77	1.92	1276	1.98	2.15						

Unit 50TCM - A07 - 6 Tons - 400V - 50Hz (Continued)

Air Flow Rate (CFM)	Available External Static Pressure (in. wg)														
	1.2			1.4			1.6			1.8			2.0		
	RPM	KWI	BHP	RPM	KWI	BHP	RPM	KWI	BHP	RPM	KWI	BHP	RPM	KWI	BHP
1800	1188	1.22	1.33	1249	1.39	1.51	1307	1.57	1.70	1363	1.75	1.90	1373	1.93	2.10
1950	1223	1.37	1.49	1284	1.55	1.68	1342	1.73	1.88	1396	1.92	2.09			
2100	1261	1.54	1.67	1320	1.72	1.87	1376	1.92	2.08	1431	2.11	2.29			
2250	1298	1.72	1.87	1356	1.92	2.08	1412	2.11	2.29						
2400	1337	1.92	2.09	1394	2.13	2.31									
2550	1376	2.15	2.33												
2700															
2850															

Unit 50TCM - D08 - 7.5 Tons - 400V - 50Hz

Air Flow Rate (CFM)	Available External Static Pressure (in. wg)														
	0.2			0.4			0.6			0.8			1.0		
	RPM	KWI	BHP	RPM	KWI	BHP	RPM	KWI	BHP	RPM	KWI	BHP	RPM	KWI	BHP
2250	511	0.44	0.48	591	0.61	0.66	660	0.80	0.86	722	1.00	1.07	779	0.82	0.89
2438	540	0.54	0.58	616	0.71	0.77	683	0.91	0.97	743	1.12	1.20	799	0.94	1.02
2625	569	0.64	0.68	642	0.83	0.89	706	1.03	1.11	765	1.24	1.34	819	1.06	1.15
2813	599	0.76	0.81	669	0.96	1.03	731	1.17	1.25	788	1.38	1.49	841	1.19	1.30
3000	630	0.89	0.95	696	1.10	1.18	756	1.31	1.42	811	1.54	1.67	863	1.34	1.46
3188	661	1.03	1.11	724	1.26	1.35	782	1.48	1.60	836	1.72	1.86	886	1.50	1.63
3375	692	1.20	1.29	753	1.42	1.54	808	1.66	1.80	861	1.91	2.08	910	1.67	1.82
3563	723	1.38	1.49	782	1.61	1.75	836	1.87	2.03	887	2.12	2.30			
3750	755	1.57	1.70	811	1.82	1.98	864	2.09	2.27						

Unit 50TCM - D08 - 7.5 Tons - 400V - 50Hz (Continued)

Air Flow Rate (CFM)	Available External Static Pressure (in. wg)														
	1.2			1.4			1.6			1.8			2.0		
	RPM	KWI	BHP	RPM	KWI	BHP	RPM	KWI	BHP	RPM	KWI	BHP	RPM	KWI	BHP
2250	832	1.42	1.54	882	1.65	1.79	928	1.90	2.06						
2438	851	1.55	1.68	899	1.79	1.94									
2625	870	1.69	1.84	918	1.94	2.11									
2813	890	1.86	2.02												
3000	912	2.04	2.21												
3188															
3375															
3563															
3750															

Legend:

Normal Font - Field Installed Drive Package

Bold Font - Standard Drive Package + Standard Motor.

Italics Font - Medium Drive Package + Medium Static Motor.

RPM - Revolutions Per Minute

KWI - Kilo Watts Input to Motor

BHP - Brake Horsepower Input to Fan

CFM - Cubic Feet per Minute

in.wg - Inch Water Gage

Notes:

- Do not adjust motor rpm such that motor maximum bhp and/or watts is exceeded at the maximum operatin cfm.
- Static Pressure (i.e Filters) must be added to external static pressure before entering fan performance table.
- Interpolation is permissible. Do not extrapolate.
- Fan performance is based on wet coils, clean filters and casing loses.
- Extensive motor and drive testing on these units ensures that the full brake horsepower and watts range of the motor can be utilized with confidence. Using your fan motors up to the watts or bhp rating shown will not result in nuisance tripping or premature motor failure. Unit warranty will not be affected.
- Bold data shows the range of air flow rate for unit management system, other rpms require field-supplied drive.
- Use of field-supplied motor may affect wiring size. Contact your Carrier representative for details.
- Conversion - Bhp to KWI

$$KWI = \frac{Bhp \times 0.746}{\text{Motor efficiency}}$$

Table - 5 Fan Performance (Continued)

Unit 50TCM - D09 - 8.5 Tons - 400V - 50Hz

Air Flow Rate (CFM)	Available External Static Pressure (in. wg)														
	0.2			0.4			0.6			0.8			1.0		
	RPM	KWI	BHP	RPM	KWI	BHP	RPM	KWI	BHP	RPM	KWI	BHP	RPM	KWI	BHP
2550	477	0.42	0.45	556	0.56	0.60	624	0.69	0.74	685	0.83	0.89	742	0.95	1.03
2763	503	0.51	0.54	578	0.65	0.70	644	0.80	0.86	704	0.95	1.01	759	1.09	1.18
2975	529	0.60	0.65	601	0.77	0.83	665	0.93	0.99	724	1.08	1.16	777	1.23	1.34
3188	556	0.72	0.77	625	0.90	0.96	687	1.06	1.14	744	1.21	1.32	796	1.39	1.50
3400	583	0.86	0.92	650	1.03	1.11	710	1.21	1.30	765	1.38	1.49	816	1.56	1.69
3613	611	1.00	1.08	675	1.19	1.27	733	1.38	1.48	787	1.55	1.68	836	1.74	1.89
3825	639	1.16	1.24	701	1.36	1.46	757	1.55	1.68	808	1.74	1.89	857	1.94	2.11
3950	668	1.34	1.44	727	1.56	1.67	781	1.74	1.89	832	1.95	2.12	879	2.17	2.35
4250	696	1.54	1.65	753	1.74	1.89	806	1.96	2.13	855	2.18	2.37			

Unit 50TCM - D09 - 8.5 Tons - 400V - 50Hz (Continued)

Air Flow Rate (CFM)	Available External Static Pressure (in. wg)														
	1.2			1.4			1.6			1.8			2.0		
	RPM	KWI	BHP	RPM	KWI	BHP	RPM	KWI	BHP	RPM	KWI	BHP	RPM	KWI	BHP
2550	794	1.10	1.19	842	1.24	1.35	888	1.39	1.50	932	1.53	1.66			
2763	810	1.23	1.34	858	1.39	1.50	903	1.54	1.67						
2975	827	1.39	1.50	874	1.55	1.68	919	1.71	1.86						
3188	845	1.56	1.69	891	1.72	1.87									
3400	864	1.73	1.88	909	1.92	2.08									
3613	883	1.93	2.10	928	2.13	2.31									
3825	903	2.15	2.33												
3950															
4250															

Unit 50TCM - D12 - 10 Tons - 400V - 50Hz

Air Flow Rate (CFM)	Available External Static Pressure (in. wg)														
	0.2			0.4			0.6			0.8			1.0		
	RPM	KWI	BHP	RPM	KWI	BHP	RPM	KWI	BHP	RPM	KWI	BHP	RPM	KWI	BHP
3000	556	0.66	0.72	623	0.81	0.88	684	0.96	1.05	738	1.12	1.22	789	1.28	1.39
3250	590	0.80	0.87	655	0.97	1.06	713	1.14	1.24	766	1.31	1.42	815	1.48	1.61
3500	625	0.97	1.06	687	1.15	1.25	742	1.34	1.45	794	1.52	1.65	841	1.70	1.85
3750	661	1.18	1.28	719	1.37	1.49	773	1.56	1.69	822	1.75	1.90	869	1.96	2.12
4000	697	1.39	1.51	753	1.60	1.74	804	1.81	1.97	852	2.02	2.19	897	2.23	2.42
4250	733	1.64	1.78	787	1.84	2.00	836	2.09	2.27	883	2.31	2.51	926	2.52	2.74
4500	770	1.91	2.08	821	2.16	2.34	869	2.39	2.60	914	2.62	2.85	956	2.86	3.10

Unit 50TCM - D12 - 10 Tons - 400V - 50Hz (Continued)

Air Flow Rate (CFM)	Available External Static Pressure (in. wg)														
	1.2			1.4			1.6			1.8			2.0		
	RPM	KWI	BHP	RPM	KWI	BHP	RPM	KWI	BHP	RPM	KWI	BHP	RPM	KWI	BHP
3000	836	1.44	1.56	881	1.59	1.73	923	1.75	1.90	963	1.91	2.08	1001	2.08	2.26
3250	861	1.65	1.79	904	1.81	1.97	945	1.99	2.16	985	2.16	2.34	1023	2.33	2.53
3500	886	1.88	2.05	929	2.07	2.24	969	2.25	2.44	1008	2.43	2.64	1045	2.61	2.84
3750	912	2.15	2.33	954	2.34	2.54	994	2.53	2.75	1031	2.74	2.97	1068	2.93	3.18
4000	940	2.43	2.64	980	2.64	2.87	1019	2.85	3.09	1056	3.06	3.32	1092	3.26	3.54
4250	968	2.75	2.98	1007	2.97	3.22	1045	3.19	3.47	1081	3.40	3.70	1117	3.63	3.94
4500	996	3.09	3.36	1035	3.32	3.61	1072	3.56	3.86	1108	3.79	4.11			

Legend:

Normal Font - Field Installed Drive Package

Bold Font - Standard Drive Package + Standard Motor.

Italics Font - Medium Drive Package + Medium Static Motor.

RPM - Revolutions Per Minute

KWI - Kilo Watts Input to Motor

BHP - Brake Horsepower Input to Fan

CFM - Cubic Feet per Minute

in.wg - Inch Water Gage

Notes:

1. Do not adjust motor rpm such that motor maximum bhp and/or watts is exceeded at the maximum operatin cfm.
2. Static Pressure (i.e Filters) must be added to external static pressure before entering fan performance table.
3. Interpolation is permissible. Do not extrapolate.
4. Fan performance is based on wet coils, clean filters and casing losses.
5. Extensive motor and drive testing on these units ensures that the full brake horsepower and watts range of the motor can be utilized with confidence. Using your fan motors up to the watts or bhp rating shown will not result in nuisance tripping or premature motor failure. Unit warranty will not be affected.
6. Bold data shows the range of air flow rate for unit management system, other rpms require field-supplied drive.
7. Use of field-supplied motor may affect wiring size. Contact your Carrier representative for details.
8. Conversion - Bhp to KWI

$$KWI = \frac{Bhp \times 0.746}{\text{Motor efficiency}}$$

Table - 5 Fan Performance (Continued)

Unit 50TCM - D13 - 11 Tons - 400V - 50Hz

Air Flow Rate (CFM)	Available External Static Pressure (in. wg)														
	0.2			0.4			0.6			0.8			1.0		
	RPM	KWI	BHP	RPM	KWI	BHP	RPM	KWI	BHP	RPM	KWI	BHP	RPM	KWI	BHP
3700	621	0.98	1.06	679	1.15	1.25	734	1.33	1.44	786	1.51	1.64	837	1.70	1.84
4063	665	1.21	1.32	717	1.39	1.51	769	1.58	1.72	818	1.78	1.94	866	1.98	2.15
4375	706	1.48	1.61	757	1.68	1.82	805	1.88	2.04	852	2.09	2.27	897	2.31	2.50
4688	749	1.79	1.95	797	2.00	2.17	843	2.21	2.40	887	2.44	2.65	930	2.67	2.89
5000	793	2.14	2.33	838	2.37	2.58	881	2.60	2.82	923	2.83	3.07	965	3.06	3.33
5313	837	2.55	2.77	880	2.78	3.02	921	3.03	3.29	961	3.26	3.54	1000	3.52	3.82
5700	882	3.00	3.25	922	3.24	3.52	961	3.49	3.79						

Unit 50TCM - D13 - 11 Tons - 400V - 50Hz (Continued)

Air Flow Rate (CFM)	Available External Static Pressure (in. wg)														
	1.2			1.4			1.6			1.8			2.0		
	RPM	KWI	BHP	RPM	KWI	BHP	RPM	KWI	BHP	RPM	KWI	BHP	RPM	KWI	BHP
3700	885	1.89	2.05	932	2.09	2.27	978	2.30	2.49	1022	2.50	2.72			
4063	912	2.19	2.38	957	2.40	2.61	1001	2.61	2.83	1043	2.83	3.07			
4375	941	2.52	2.74	984	2.74	2.98	1026	2.97	3.22						
4688	972	2.89	3.14	1013	3.12	3.39									
5000	1005	3.31	3.59	1044	3.55	3.85									
5313															
5700															

Legend:

Normal Font - Field Installed Drive Package

Bold Font - Standard Drive Package + Standard Motor.

Italics Font - Medium Drive Package + Medium Static Motor.

RPM - Revolutions Per Minute

KWI - Kilo Watts Input to Motor

BHP - Brake Horsepower Input to Fan

CFM - Cubic Feet per Minute

in.wg - Inch Water Gage

Notes:

- Do not adjust motor rpm such that motor maximum bhp and/or watts is exceeded at the maximum operatin cfm.
- Static Pressure (i.e Filters) must be added to external static pressure before entering fan performance table.
- Interpolation is permissible. Do not extrapolate.
- Fan performance is based on wet coils, clean filters and casing loses.
- Extensive motor and drive testing on these units ensures that the full brake horsepower and watts range of the motor can be utilized with confidence. Using your fan motors up to the watt or bhp rating shown will not result in nuisance tripping or premature motor failure. Unit warranty will not be affected.
- Bold data shows the range of air flow rate for unit management system, other rpms require field-supplied drive.
- Use of field-supplied motor may affect wiring size. Contact your Carrier representative for details.
- Conversion - Bhp to KWI

$$KWI = \frac{Bhp \times 0.746}{\text{Motor efficiency}}$$

Charging Chart 400V-50Hz 50TCMA07

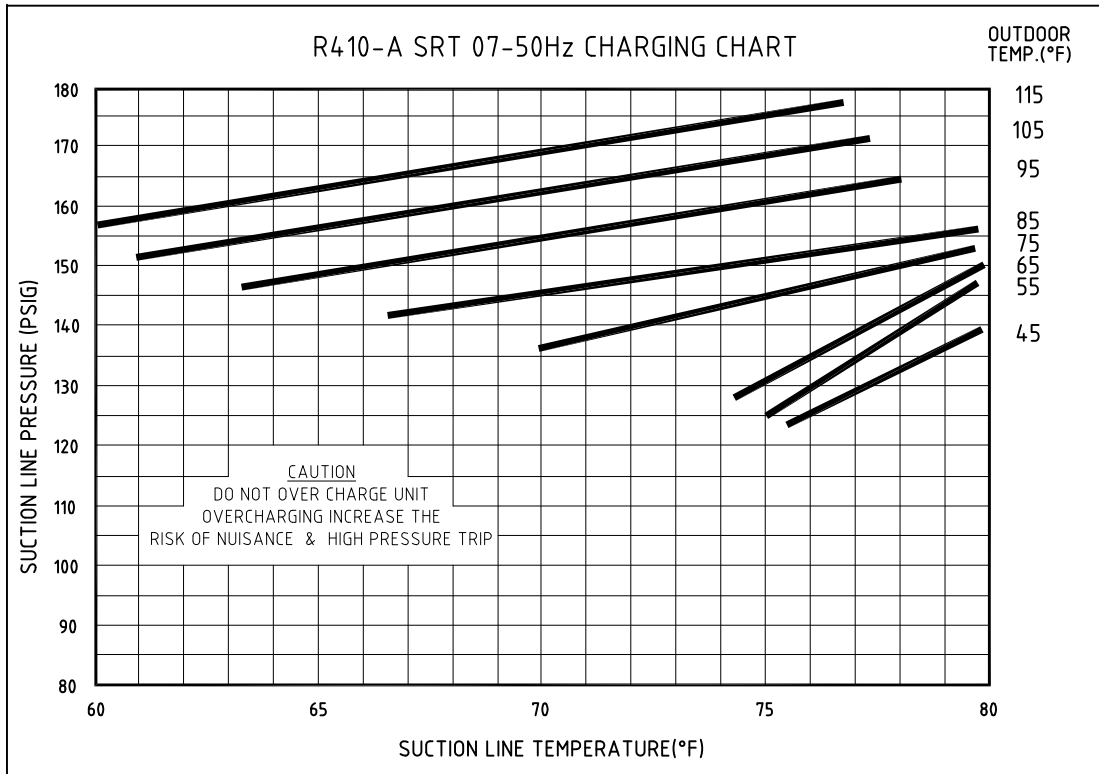

Charging Chart 400V-50Hz 50TCMD08 CIR # 1

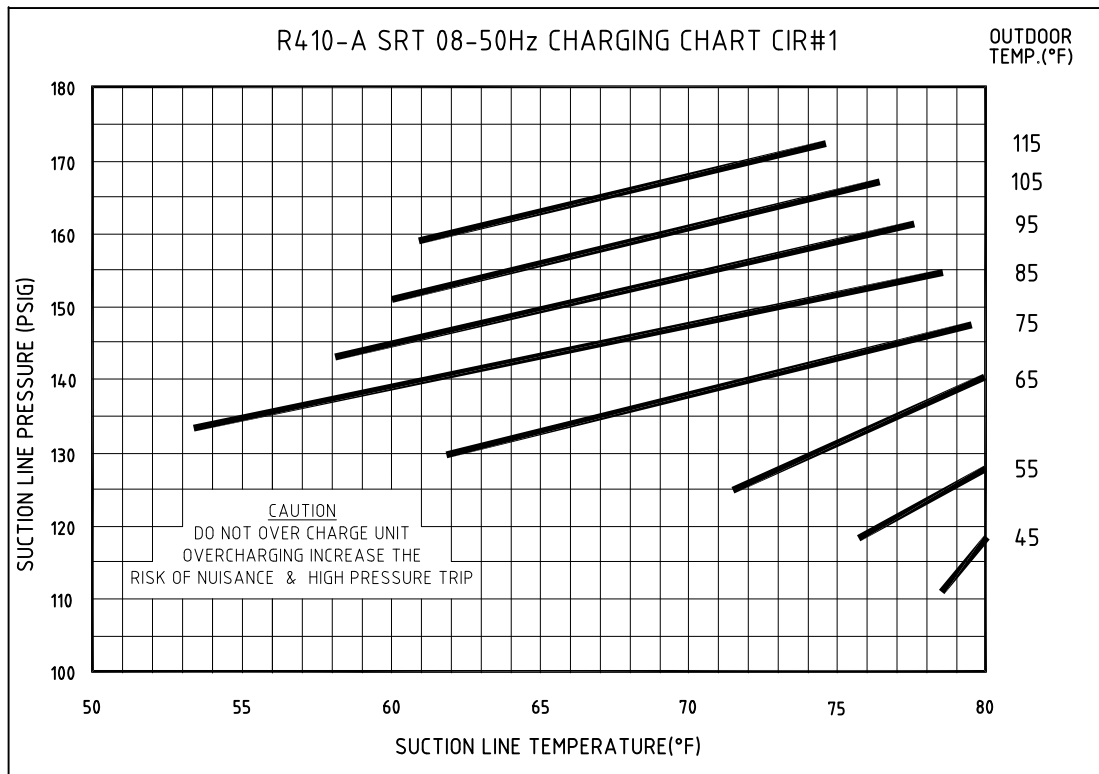

Charging Chart 400V-50Hz 50TCMD08 CIR # 2

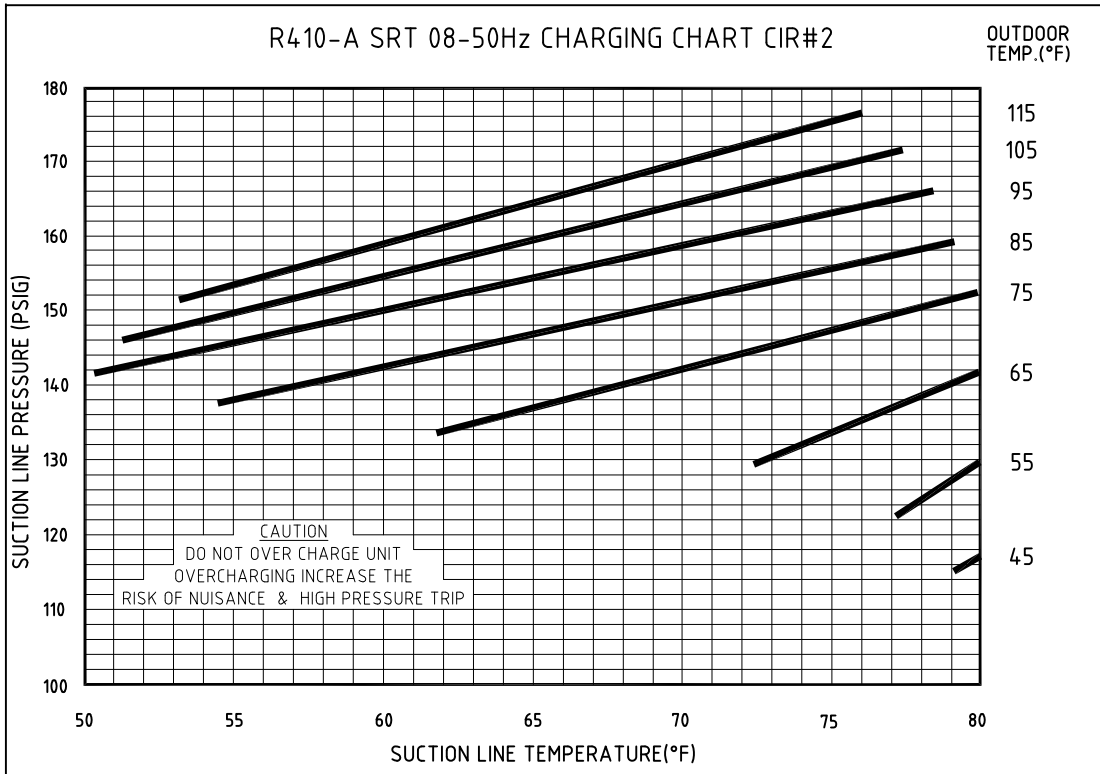

Charging Chart 400V-50Hz 50TCMD09 CIR # 1

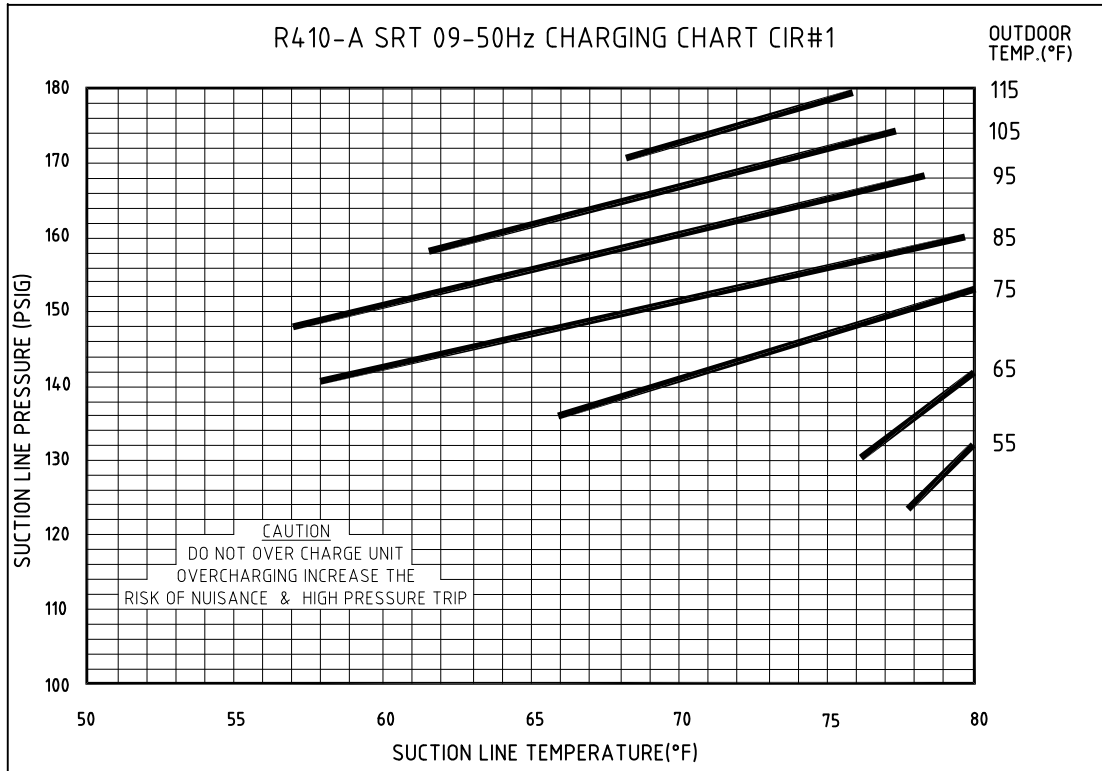

Charging Chart 400V-50Hz 50TCMD09 CIR # 2

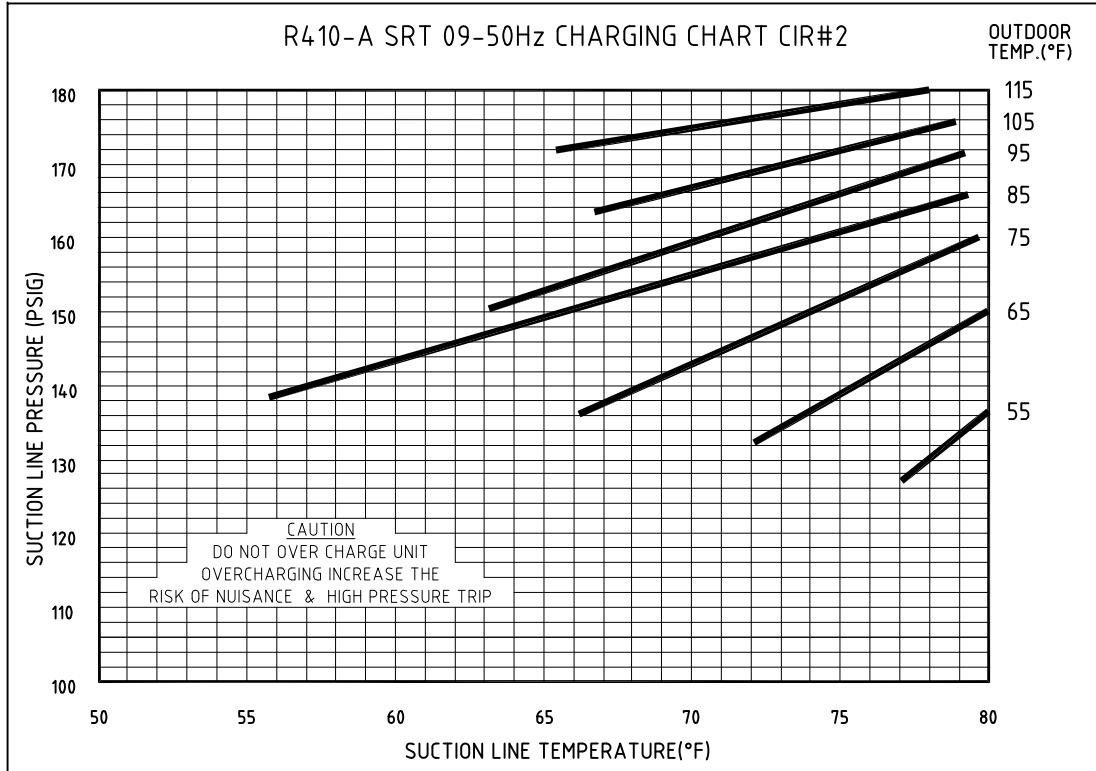

Charging Chart 400V-50Hz 50TCMD12 CIR # 1

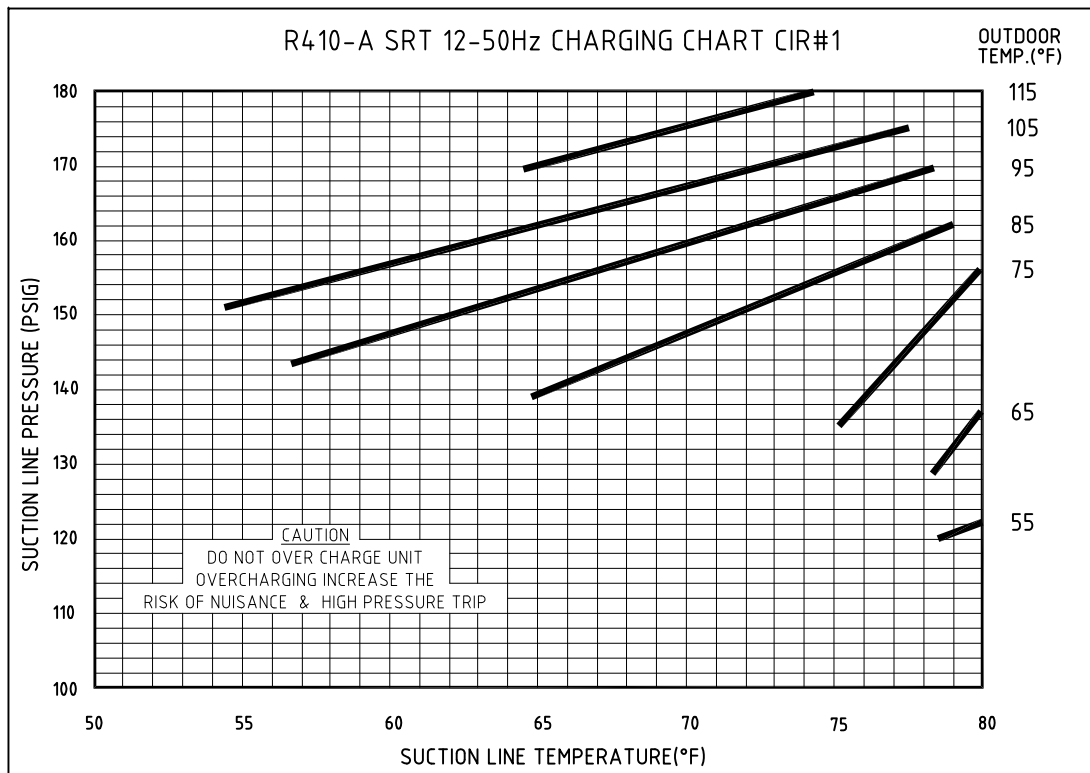

Charging Chart 400V-50Hz 50TCMD12 CIR # 2

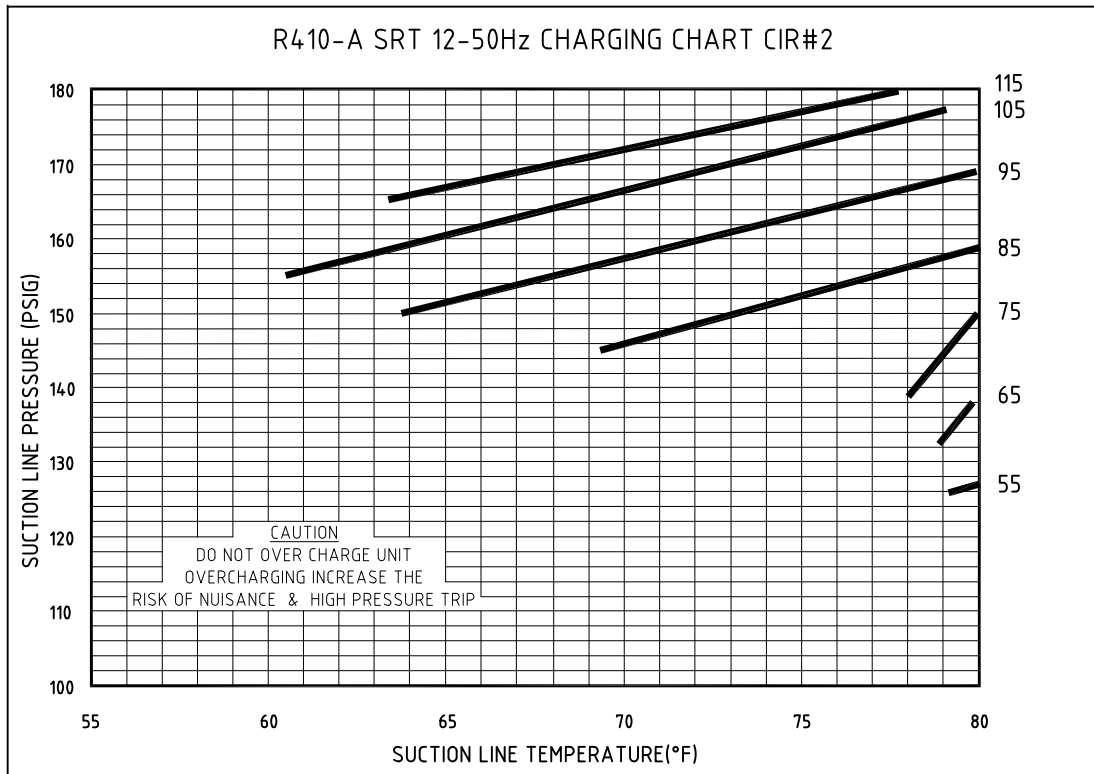

Charging Chart 400V-50Hz 50TCMD13 CIR #1 & CIR # 2

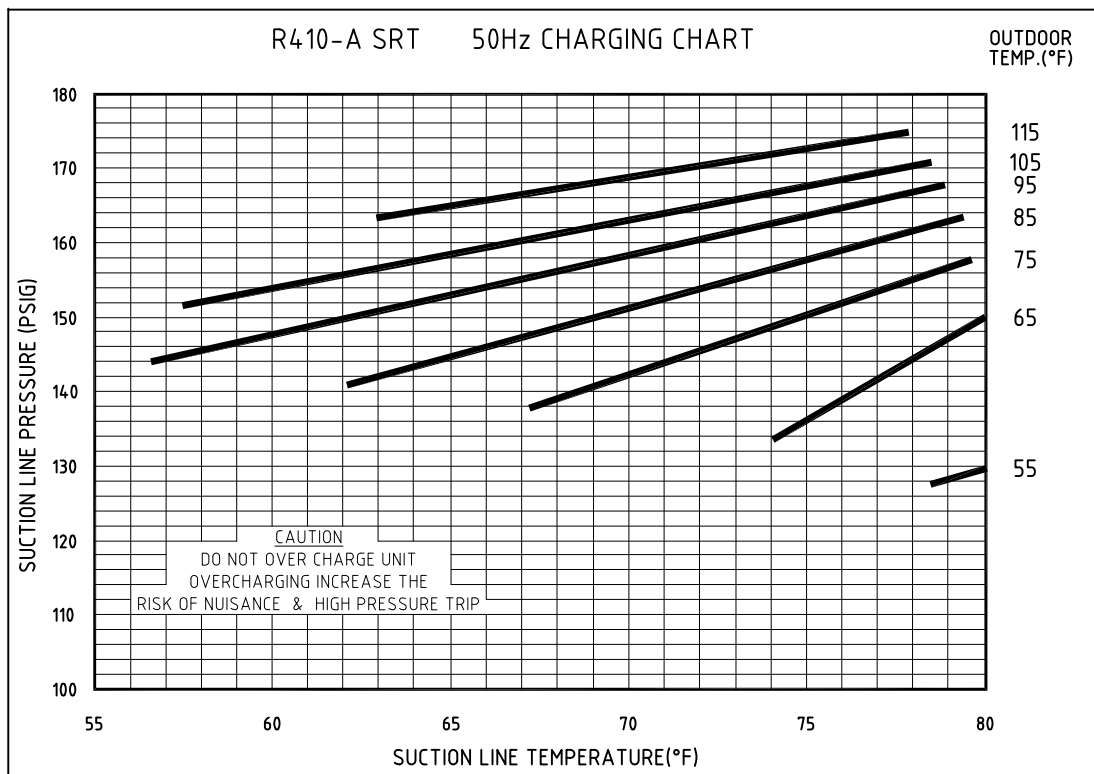

ATTENTION INSTALLERS AND SERVICE TECHNICIANS!

R-410A Refrigerant Quick Reference Guide

- R-410A refrigerant operates at 50-70 percent higher pressures than R-22. Be sure that servicing equipment and replacement components are designed to operate with R-410A refrigerant.
- R-410A refrigerant cylinders are rose colored.
- Recovery cylinder service pressure rating must be 400 psig, DOT 4BA400 or DOT BW400.
- R-410A refrigerant systems should be charged with liquid refrigerant. Use a commercial type metering device in the manifold hose when charging into suction line with compressor operating.
- Manifold sets should be 700 psig high side and 180 psig low side with 550 psig low-side retard.
- Use hoses with 700 psig service pressure rating.
- Leak detectors should be designed to detect HFC refrigerant.
- R-410A refrigerant, as with other HFCs, is only compatible with POE oils.
- Vacuum pumps will not remove moisture from oil.
- Do not use liquid-line filter driers with rated working pressures less than 600 psig.
- Do not leave R-410A refrigerant suction line filter driers in line longer than 72 hours.
- Do not install a suction-line filter drier in liquid-line.
- POE oils absorb moisture rapidly. Do not expose oil to atmosphere.
- POE oils may cause damage to certain plastics and roofing materials.
- Wrap all filter driers and service valves with wet cloth when brazing.
- A factory-approved liquid-line filter drier is required on every unit.
- Do NOT use an R-22 expansion device.
- If indoor unit is equipped with an R-22 expansion device, it must be changed to a hard-shutoff R-410A refrigerant expansion device.
- Never open system to atmosphere while it is under a vacuum.
- When system must be opened for service, recover refrigerant, evacuate then break vacuum with dry nitrogen and replace filter driers. Evacuate to 500 microns prior to recharging.
- All indoor coils must be installed with a hard-shutoff R-410A refrigerant expansion metering device.
- Do not vent R-410A refrigerant into the atmosphere.
- Do not use capillary tube coils.
- Observe all **warnings**, **cautions**, and **bold** text.

Troubleshooting Guide

Cooling Service Analysis

PROBLEM	CAUSE	REMEDY
Compressor and condenser fan will not start.	Power failure.	Call power company.
	Fuse blown or circuit breaker tripped.	Replace fuse or reset circuit breaker.
	Defective thermostat, contactor, transformer, or control relay.	Replace component.
	Insufficient line voltage.	Determine cause and correct.
	Incorrect or faulty wiring.	Check wiring diagram and rewire correctly.
	Thermostat setting too high.	Lower thermostat setting below room temperature.
Compressor will not start but condenser fan runs.	Faulty wiring or loose connections in compressor circuit.	Check wiring and repair or replace.
	Compressor motor burned out, seized, or internal overload open.	Determine cause. Replace compressor.
	Defective overload.	Determine cause and replace.
	Compressor locked out	Determine cause for safety trip and reset lockout.
	One leg of 3-phase power dead.	Replace fuse or reset circuit breaker. Determine cause.
Compressor cycles (other than normally satisfying thermostat).	Refrigerant overcharge or undercharge.	Recover refrigerant, evacuate system, and recharge to nameplate.
	Defective compressor.	Replace and determine cause.
	Insufficient line voltage.	Determine cause and correct.
	Blocked condenser.	Determine cause and correct.
	Defective overload.	Determine cause and replace.
	Defective thermostat.	Replace thermostat.
	Faulty condenser-fan motor.	Replace.
	Restriction in refrigerant system.	Locate restriction and remove.
Compressor operates continuously.	Dirty air filter.	Replace filter.
	Unit undersized for load.	Decrease load or increase unit size.
	Thermostat set too low.	Reset thermostat.
	Low refrigerant charge.	Locate leak, repair, and recharge.
	Air in system.	Recover refrigerant, evacuate system, and recharge.
	Condenser coil dirty or restricted.	Clean coil or remove restriction.
Excessive head pressure.	Dirty drier filter.	Replace filter.
	Dirty condenser coil.	Clean coil.
	Refrigerant overcharged.	Recover excess refrigerant.
	Faulty TXV.	1. Check TXV bulb mounting and secure tightly to suction line. 2. Replace TXV if stuck open or closed.
	Air in system.	Recover refrigerant, evacuate system, and recharge.
	Condenser air restricted or air short-cycling.	Determine cause and correct.
Head pressure too low.	Low refrigerant charge.	Check for leaks, repair, and recharge.
	Restriction in liquid tube.	Remove restriction.
Excessive suction pressure.	High heat load.	Check for source and eliminate.
	Faulty TXV.	1. Check TXV bulb mounting and secure tightly to suction line. 2. Replace TXV if stuck open or closed.
	Refrigerant overcharged.	Recover excess refrigerant.
Suction pressure too low.	Dirty air filter.	Replace filter.
	Low refrigerant charge.	Check for leaks, repair, and recharge.
	Metering device or low side restricted.	Remove source of restriction.
	Faulty TXV.	1. Check TXV bulb mounting and secure tightly to suction line. 2. Replace TXV if stuck open or closed.
	Insufficient evaporator airflow.	Increase air quantity. Check filter and replace if necessary.
	Temperature too low in conditioned area.	Reset thermostat.
	Field-installed filter drier restricted.	Replace.

START-UP CHECKLIST

(Remove and Store in Job File)

I. PRELIMINARY INFORMATION

MODEL NO: _____

DATE: _____

SERIAL NO: _____

TECHNICIAN: _____

II. PRE-START-UP (Insert checkmark in box as each item is completed)

- 1) ALL PACKING MATERIALS HAVE BEEN REMOVED FROM THE UNIT.
- 2) VERIFY THAT UNIT INSTALLATION IS LEVEL.
- 3) CONDENSATE CONNECTION IS INSTALLED PER INSTALLATION INSTRUCTION.
- 4) UNIT GROUNDING WIRE HAS BEEN CONNECTED.
- 5) POWER WIRES HAVE BEEN SIZED AND INSTALLED PROPERLY TO THE UNIT.
- 6) CONTROL WIRING CONNECTIONS HAVE BEEN INSTALLED PROPERLY.
- 7) CHECK ALL WIRING TERMINALS HAVE BEEN TIGHTENED PROPERLY.
- 8) ENERGIZE CRANKCASE HEATERS FOR 12 HOURS.
- 9) CORRECT FAN ROTATION HAS BEEN CONFIRMED.
- 10) SEALED ALL POWER AND CONTROL WIRES ENTRY INTO THE UNIT AND INSIDE THE BOX

III. START - UP

ELECTRICAL:

SUPPLY VOLTAGE: (L1 - L2): _____ (L2 - L3): _____ (L3 - L1): _____

COMPRESSOR - 1 AMPS: (L1): _____ (L2): _____ (L3): _____

COMPRESSOR - 2 AMPS: (L1): _____ (L2): _____ (L3): _____

INDOOR FAN AMPS: (L1): _____ (L2): _____ (L3): _____

TEMPERATURES: (BOTH CIRCUITS OPERATING)

OUTDOOR AIR: _____ : DB

INDOOR SECTION ENTERING AIR: _____ : DB _____ : WB

INDOOR SECTION LEAVING AIR: _____ : DB _____ : WB

PRESSURES:

CIRCUIT - 1

REFRIGERANT SUCTION _____ :PSIG REFRIGERANT DISCHARGE _____ :PSIG

CIRCUIT - 2

REFRIGERANT SUCTION _____ :PSIG REFRIGERANT DISCHARGE _____ :PSIG

VERIFY REFRIGERANT CHARGE USING CHARGING CHART.

Notes:

(Tear Along This Line)

NOTES

